

Transfer or duplication of this document as well as the utilisation or communication of its content are not permitted unless express consent is granted. Violations give rise to claims for damages. All rights reserved in case of patent, utility model or design patent registrations.

Weitergabe sowie Vervielfältigung dieses Dokuments, Verwertung und Mitteilung seines Inhalts sind verboten, soweit nicht ausdrücklich gestattet. Zuwiderhandlungen verpflichten zu Schadenersatz. Alle Rechte für den Fall der Patent-, Gebrauchsmuster- oder Designeintragung vorbehalten.

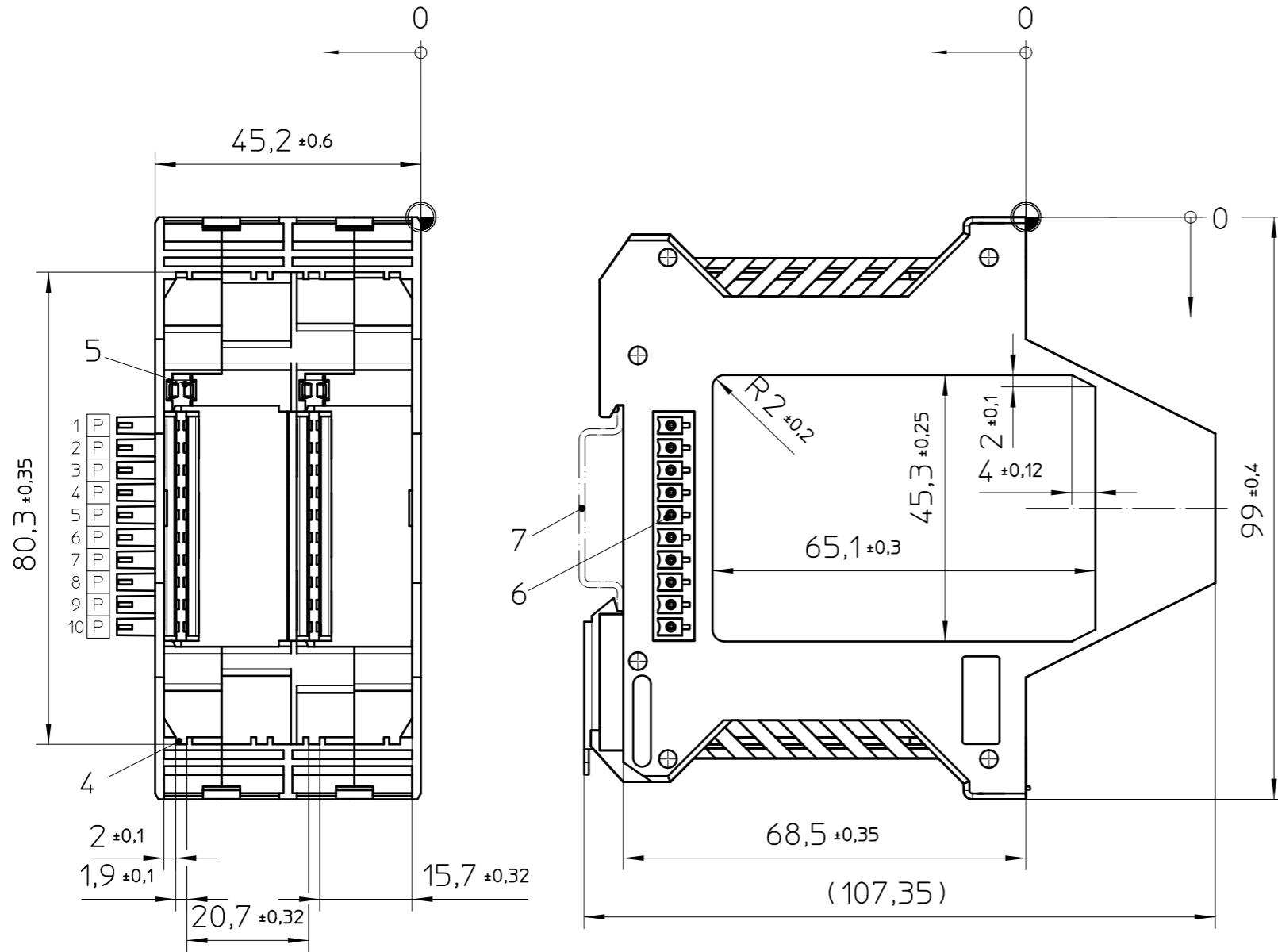

height
width
depth

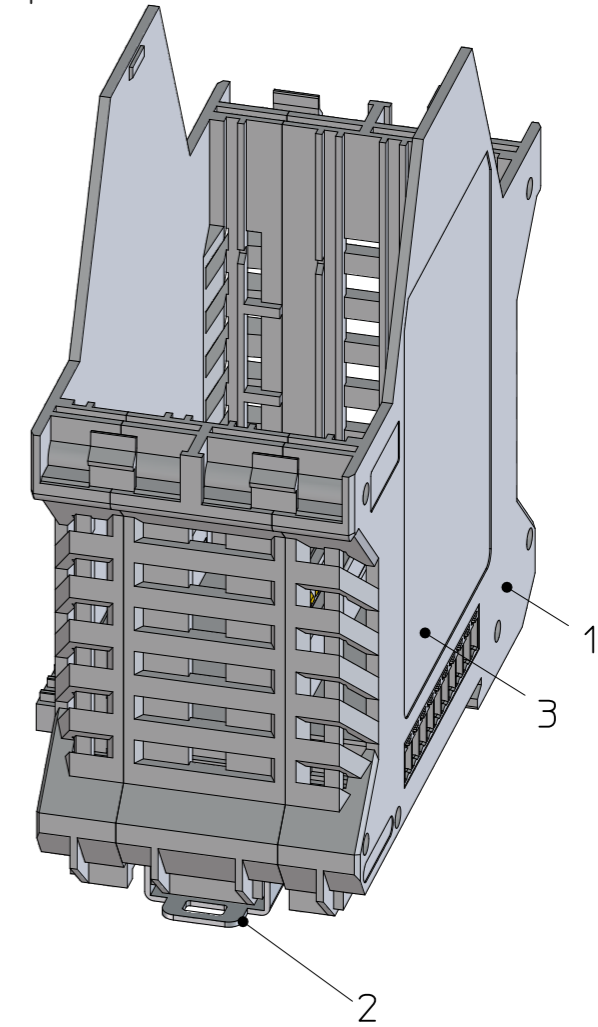

General Information

- 1. ME 45 UT
- 2. Foot catch
- 3. Marking area
- 4. PCB guidance
- 5. FE contact
- 6. ME BUS 22,5 MC 10
- 7. Mounting rail like EN 60715: TH 35-7,5/15 or mounting rail TH 35-15x1,5 similar to EN 60715
- ⊕ = Workpiece zero point for mechanical processing

- Simplified representation, exemplary shown in gray
- Document excluded from change process
- CAD Data see Download-Center on www.phoenixcontact.com
- Linear dimensions [mm]
- Tolerances, apply in a normal climate according to DIN 50014-23/50-2, with about 2% (% by weight) moisture content.
- Recommended PCB outline on www.phoenixcontact.com webcode: #0512

schematic symbol	description	electrical symbol
P	parallel	

	DIN A3	document-No. / RI	00858553 / 02	date	05.01.2026	scale	1:1
		ident.-No.	2695701	document-type	TECDC 2D_Productdrawing		
page 1	of 1	description		ME 45 UT/FE BUS/10 BK			