



BRIGHTTEK
BRIGHTTEK (EUROPE) LIMITED

Brighten up The World With LED!



ISO/TS 16949:2009

BS-EM ISO 14001:2004

QC 900000 IECQ HSP98

PRODUCT DATASHEET



- ▶ DC-In Solid State Relay
- ▶ SMD7 Low Profile
- ▶ Zero-Cross TRIAC Output

Release Date: 20 July 2025 Version: A00

TDRX213(SL)(T1)-GV



TDRX213(SL) Series



DESCRIPTION:

The TDRX213(SL) series combine an AlGaAs infrared emitting diode as the emitter which is optically coupled to a monolithic silicon zero-cross photo TRIAC to drive a power TRIAC in a plastic DIP7 package with SMD7 Low Profile lead forming option.

FEATURES:

- High isolation 5000Vrms
- DC input with TRIAC output
- Operating temperature range -40°C to +85°C
- REACH & RoHS compliance
- MSL class 1
- Regulatory Approvals:
 - UL - UL1577
 - VDE - EN60747-5-5 (VDE0884-5)
 - CQC - GB4943.1, GB8898
 - cUL - CSA Component Acceptance Service Notice 5A
- Packing: 1000pcs/reel

APPLICATIONS:

- Solenoid/valve controls
- Lighting controls
- Motor controls
- Temperature controls
- Static AC power switches
- Solid state relays
- Interfacing microprocessors to 115 to 240VAC peripherals



Partner with: LIGHTNING

NAMING & ORDERING INFORMATION:

Naming Information:

TDR X 213 (SL) (T1)- G V	
TDRX213	Part Number
X	Selection: On-State RMS Current (X=0~3)
SL	Lead Form Option: SMD7 Low Profile
T1	Selection: Tape and Reel Option (T1(default)/T2)
G	Green Option
V	VDE Option

Ordering Information:

TDRX213(SL)(T1)-GV						
\underline{X} = Selection: On-State RMS Current (X=0~3)						
Part Number	Symbol	Values			Unit	Test Condition
		Min.	Typ.	Max.		
TDR0213(SL)(T1)-GV	IT _(RMS) *	---	---	0.3	A	IT _{TSM} =3A ** P _W =100μs, 120pps
TDR1213(SL)(T1)-GV		---	---	0.6		IT _{TSM} =6A P _W =100μs, 120pps
TDR2213(SL)(T1)-GV		---	---	0.9		IT _{TSM} =9A P _W =100μs, 120pps
TDR3213(SL)(T1)-GV		---	---	1.2		IT _{TSM} =12A P _W =100μs, 120pps

* IT_(RMS) = On-State RMS Current

** IT_{TSM} = Non-repetitive Surge Current

Version No.	Original Release Date
Rev: A00	29/08/2024

SCHEMATIC DIAGRAM & MARKING:

Schematic Diagram:

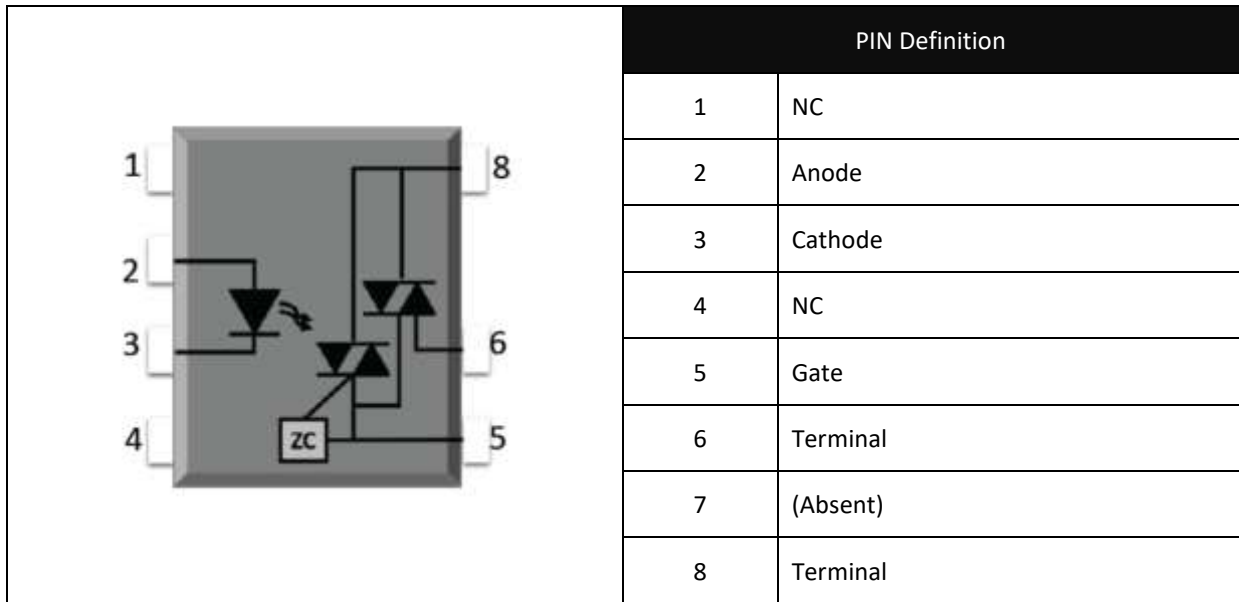

Marking Information:

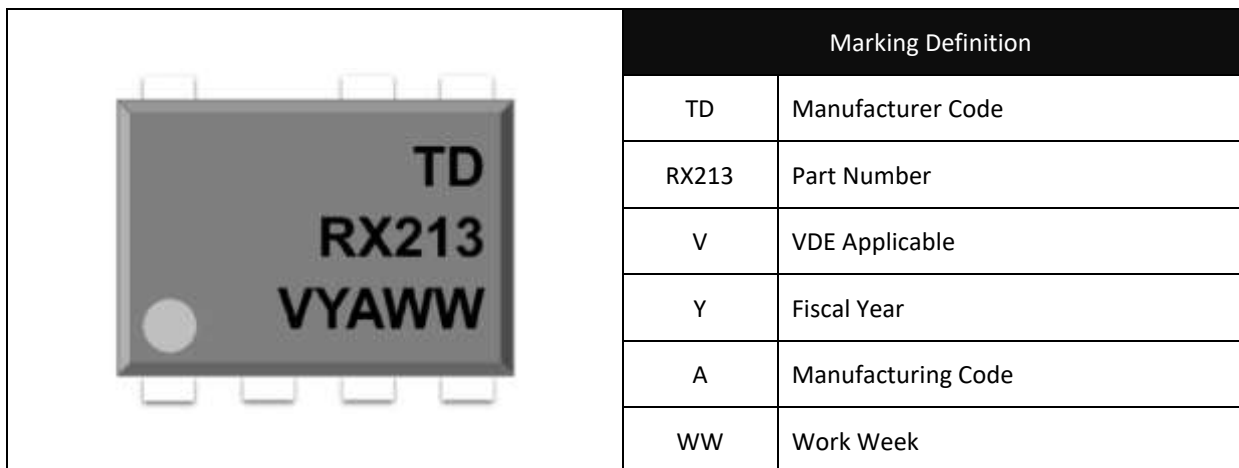

Labelling Information:

BRIGHTTEK
 BRIGHTTEK (EUROPE) LIMITED
 

Part No.: XXXXXXXXXXXX Bin Code: X



Lot No.: XXXXXXXX

Date Code: XXXX

QTY: XXX PCS



MSL: 1

Made in Quanzhou Fujian



This product is manufactured by



for Brighttek (Europe) Limited

ABSOLUTE CHARACTERISTICS:

Absolute Maximum Ratings:

Parameter	Symbol	Ratings	Unit
INPUT			
Forward Current	I_F	60	mA
Reverse Voltage	V_R	6	V
Junction Temperature	T_j	125	°C
Input Power Dissipation	P_i	100	mW
OUTPUT			
Off-State Output Terminal Voltage	V_{DRM}	600	V
On-State RMS Current	TDR0213	0.3	A
	TDR1213	0.6	
	TDR2213	0.9	
	TDR3213	1.2	
Non-repetitive Surge Current $P_w=100\mu s, 120pps$	TDR0213	3	A
	TDR1213	6	
	TDR2213	9	
	TDR3213	12	
Junction Temperature	T_j	125	°C
COMMON			
Total Power Dissipation	P_{tot}	400	mW
Isolation Voltage	V_{iso}	5000 *1	Vrms
Operating Temperature	T_{opr}	-40~+85	°C
Storage Temperature	T_{stg}	-40~+125	°C
Soldering Temperature	T_{sol}	260 *2	°C

*1. AC for 1 minute, R.H.=40~60%.

*2. For 10 seconds max.

ELECTRICAL CHARACTERISTICS:

Electrical Optical Characteristics at $T_a=25^{\circ}\text{C}$:

Parameter	Symbol	Values			Unit	Test Condition
		Min.	Typ.	Max.		
INPUT						
Forward Voltage	V_F	---	1.24	1.4	V	$I_F=10\text{mA}$
Reverse Current	I_R	---	---	10	μA	$V_R=6\text{V}$
Input Capacitance	C_{IN}	---	30	---	pF	$V=0, f=1\text{kHz}$
OUTPUT						
Peak Off-State Current Either Direction	I_{DRM}	---	---	100	μA	$V_{DRM}=600\text{V}$ $I_F=0$
On-State Terminal Voltage	V_{TM}	---	1.7	2.5	V	$I_{TM}=\text{Rated } I_{TM}$
Critical Rate of Rise of Off-State Voltage - Breakdown Voltage	dV/dt	1000	---	---	V	$V_{PEAK}=600\text{V}^{*1}$
TRANSFER CHARACTERISTICS						
LED Trigger Current	I_{FT}	---	---	10	mA	$R_L=100\Omega$ Terminal Voltage=6V
Holding Current	I_H	---	---	25	mA	---
Isolation Resistance	R_{ISO}	10^{12}	10^{14}	---	Ω	DC=500V, 40~60% R.H.
Floating Capacitance	C_{IO}	---	0.25	1	pF	$V=0, f=1\text{MHz}$
ZERO-CROSSING CHARACTERISTICS						
Inhibit Voltage	V_{INH}	---	---	20	V	$I_F=10\text{mA}$
Leakage in Inhibited State	I_{DRM2}	---	---	500	μA	$I_F=10\text{mA}$ $V_{DRM}=600\text{V}$
Response Time (Rise)	T_{ON}	---	30	---	μs	$V_D=6\text{V}, R_L=100\Omega$ $I_F=10\text{mA}$

*1. Test voltage must be applied within dV/dt rating.

CHARACTERISTIC CURVES:

Forward Current v.s. Forward Voltage

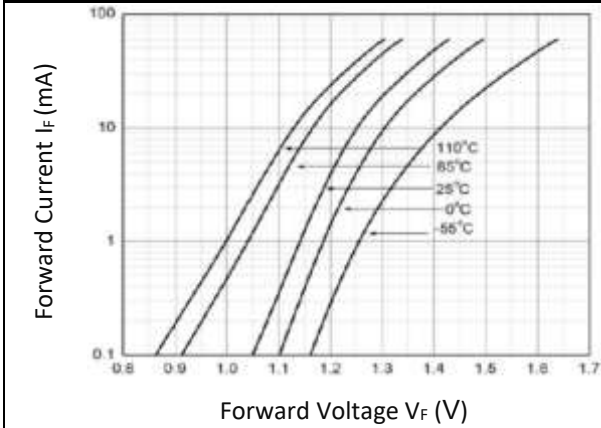

Off-State Terminal Current v.s. Ambient Temperature

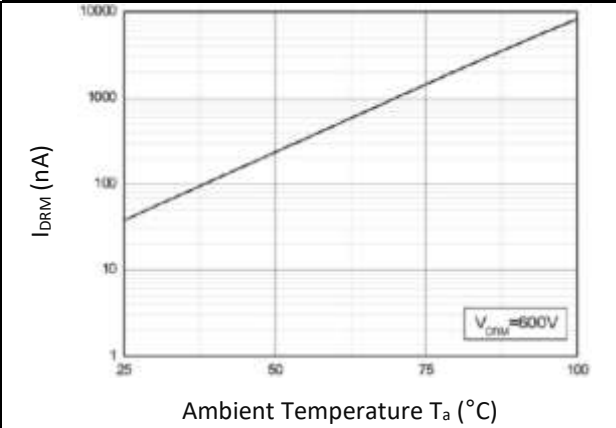

Normalized Off-State Terminal Voltage v.s. Ambient Temperature

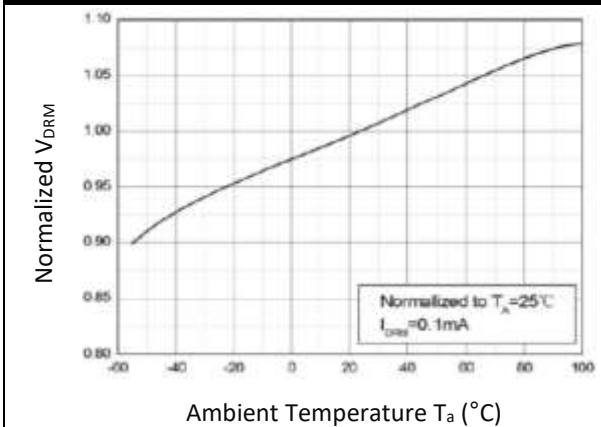

Normalized Trigger Current v.s. LED Trigger Pulse Width

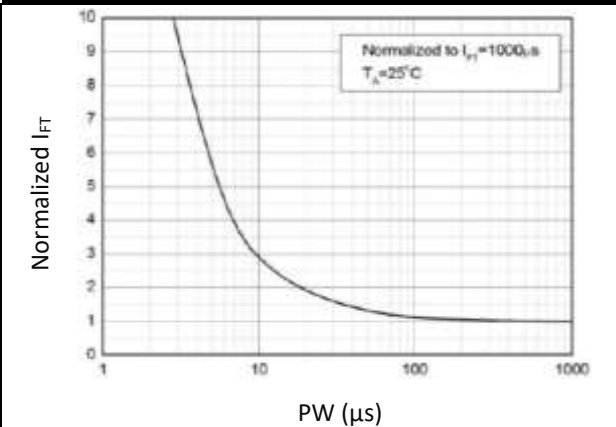

Normalized Trigger Current v.s. Ambient Temperature

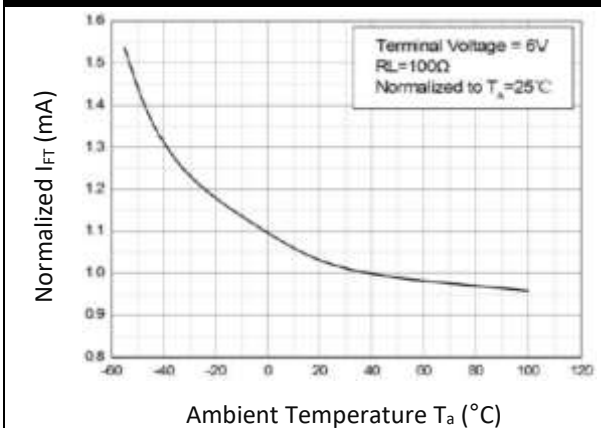

On-State Terminal Voltage v.s. Ambient Temperature

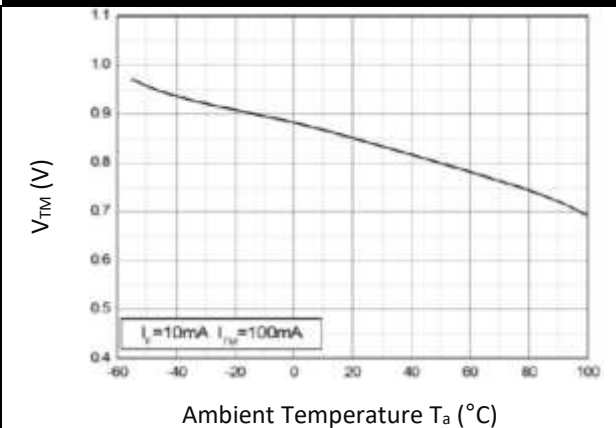

CHARACTERISTIC CURVES:

On-State Terminal Voltage v.s. On-State Terminal Current

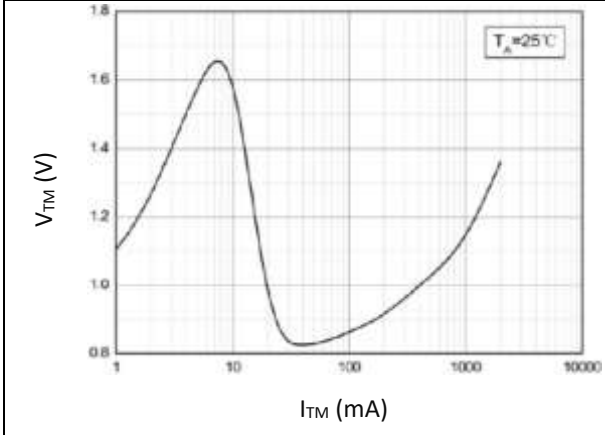

Holding Current v.s. Ambient Temperature

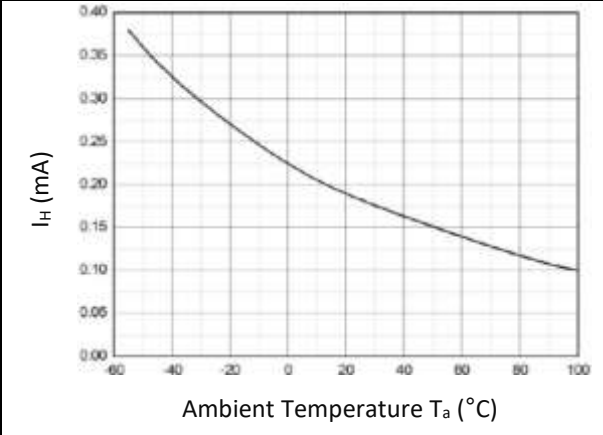

Normalized Inhibit Voltage v.s. Ambient Temperature

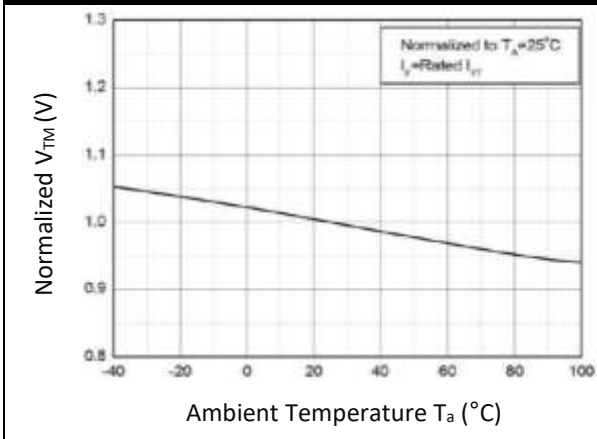

Normalized Leakage in Inhibit State v.s. Ambient Temperature

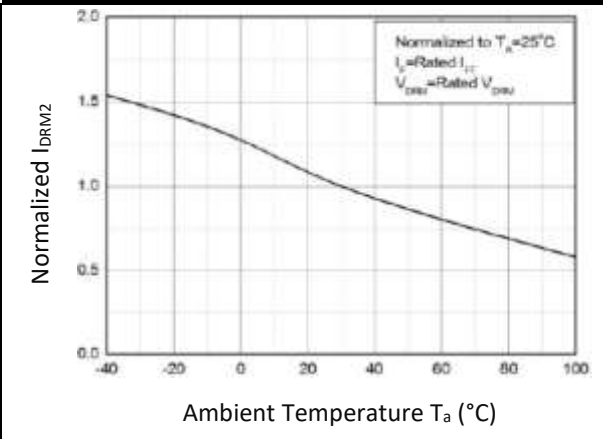

Turn On Time v.s. Forward Current

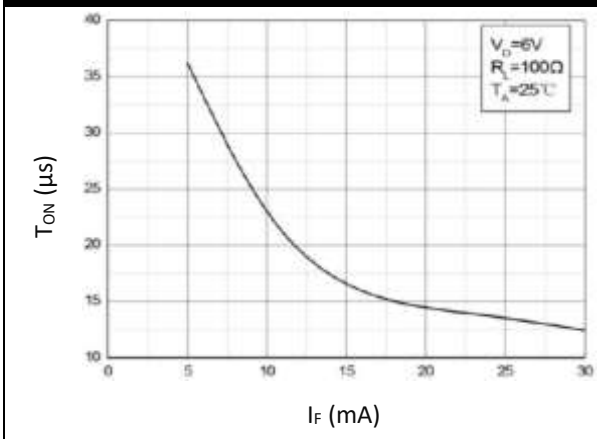

Turn On Time v.s. Ambient Temperature

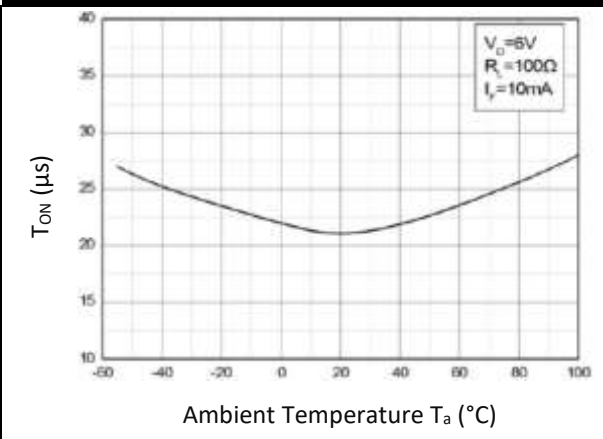

TEST CIRCUIT:

Test Circuit and Waveforms of Turn On Time:

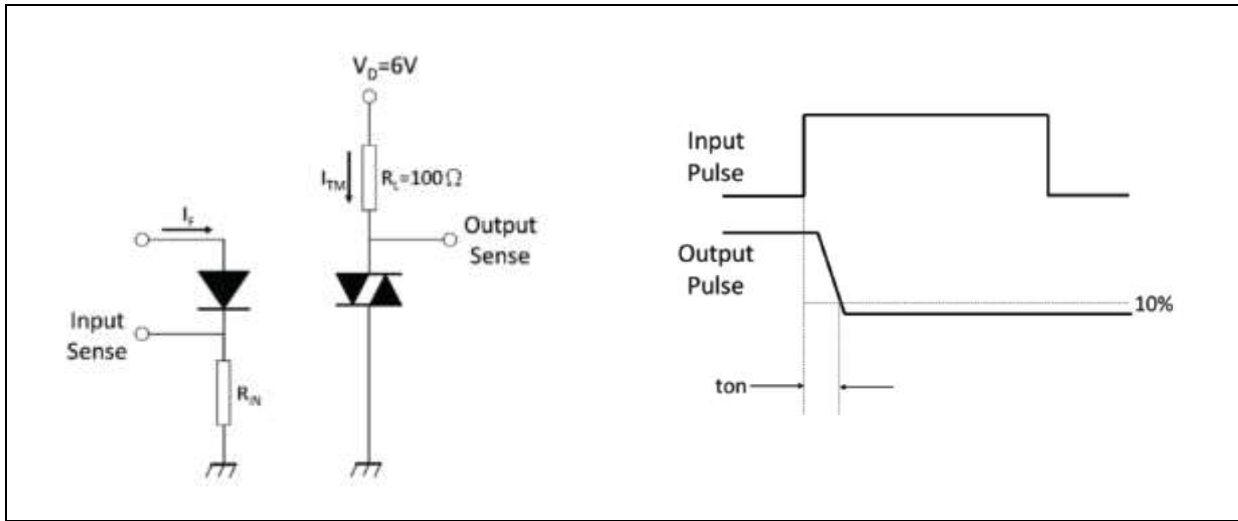

Test Circuit and Waveforms of dv/dt :

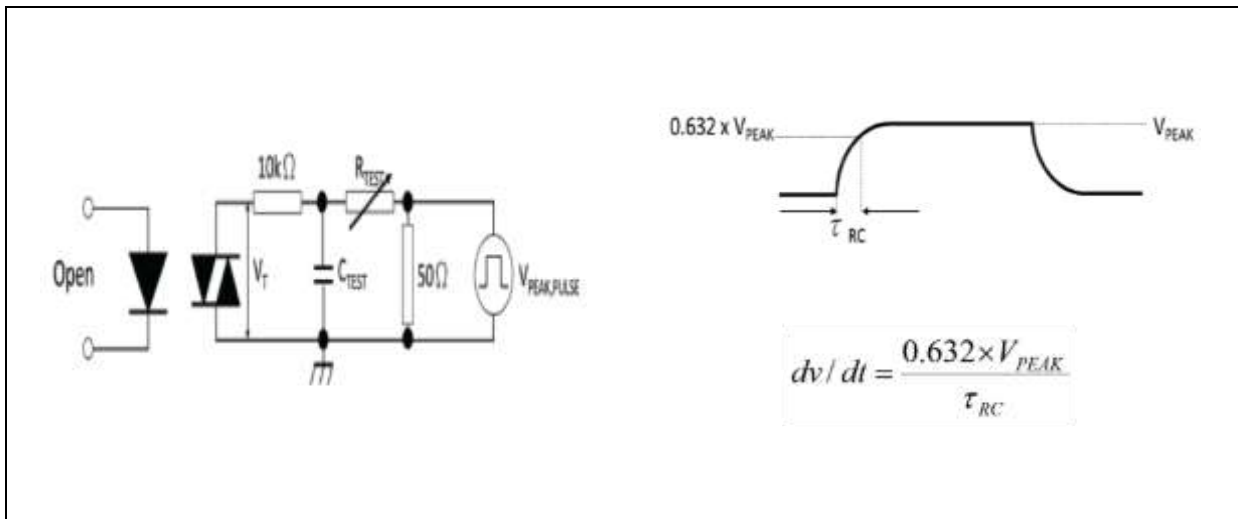

OUTLINE DIMENSION:

Package Dimension:

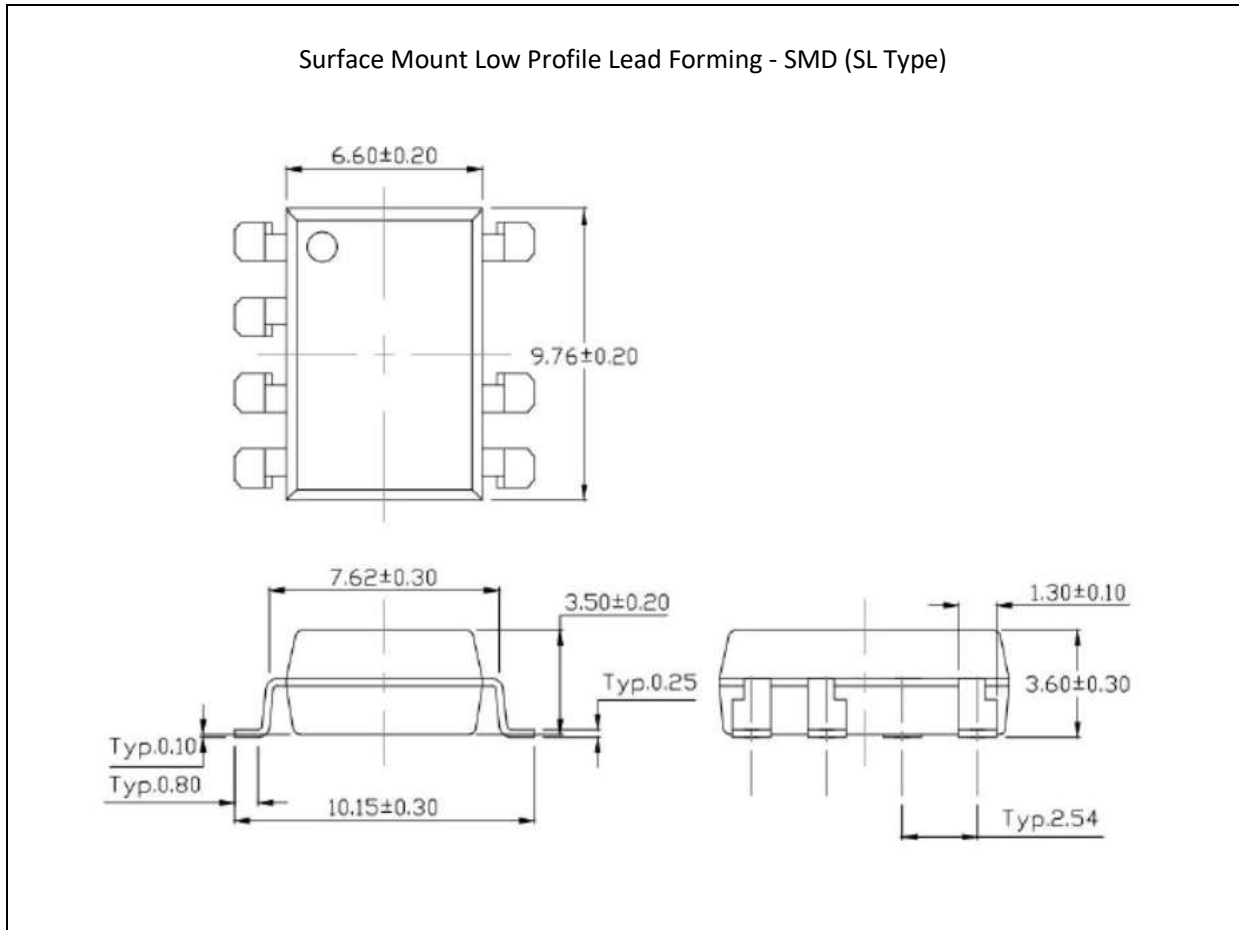

1. All dimensions are in millimetre (mm).

Recommended Soldering Mask:

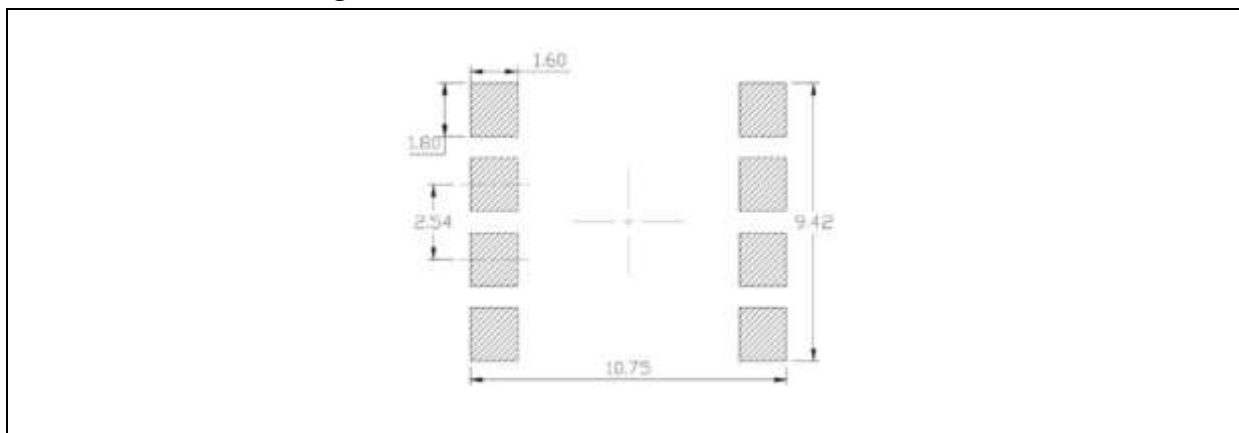

1. Dimensions are in millimetre (mm).

PACKING SPECIFICATION:

Reel Dimension:

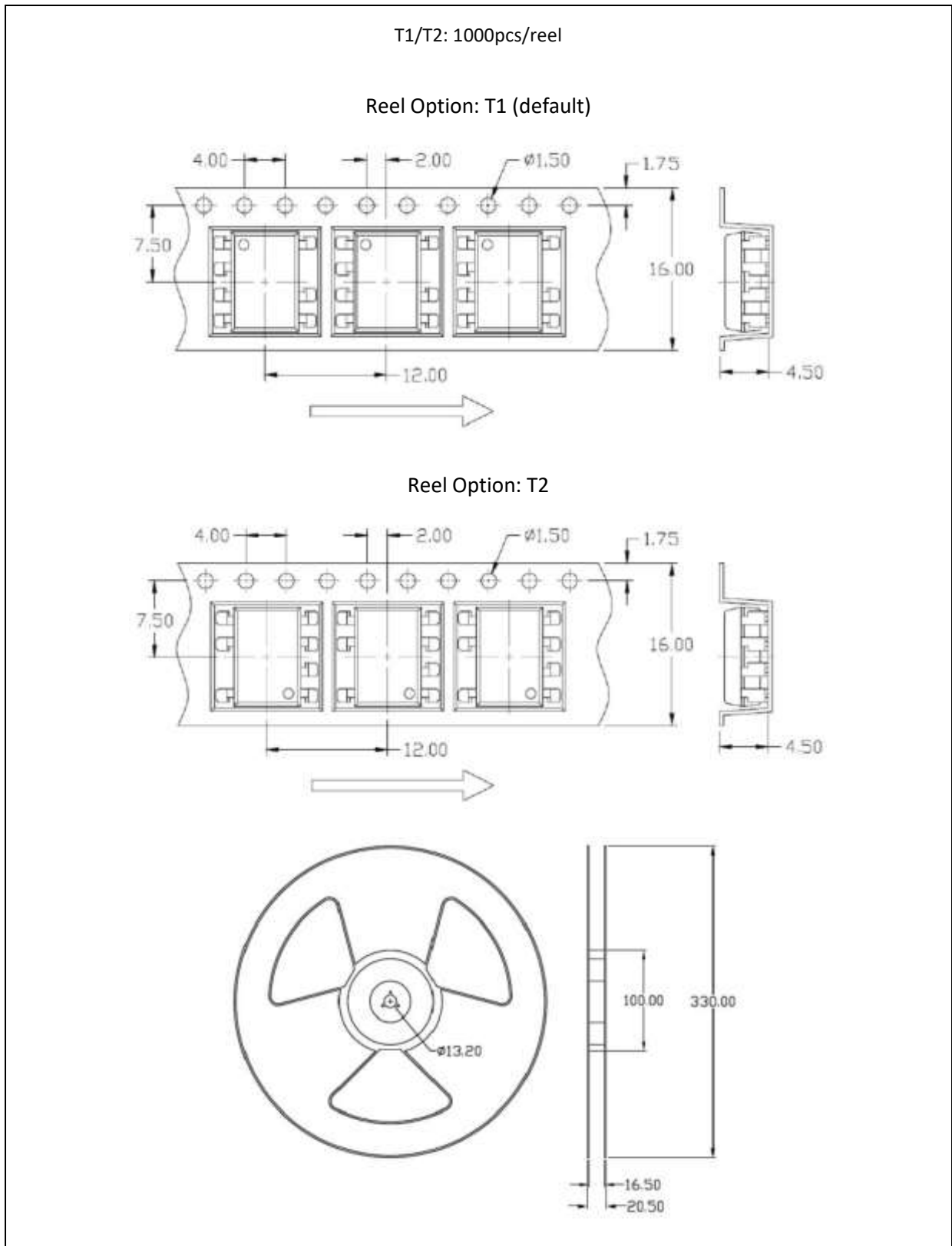

PACKING SPECIFICATION:

Box Dimension:

T1/T2: 3 reels (3Kpcs)/inner box, 5 inner boxes (15Kpcs)/carton

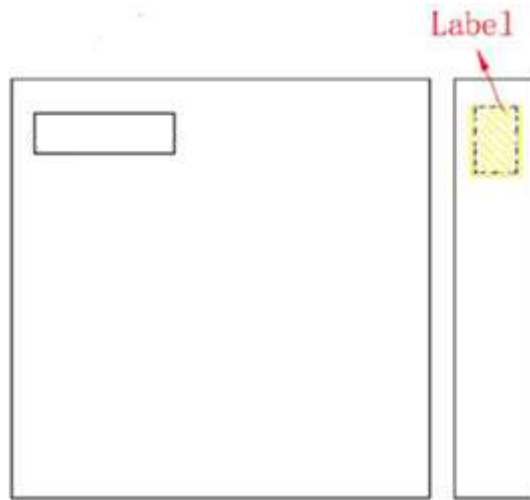

- L x W x H = 36cm x 36cm x 6.9cm

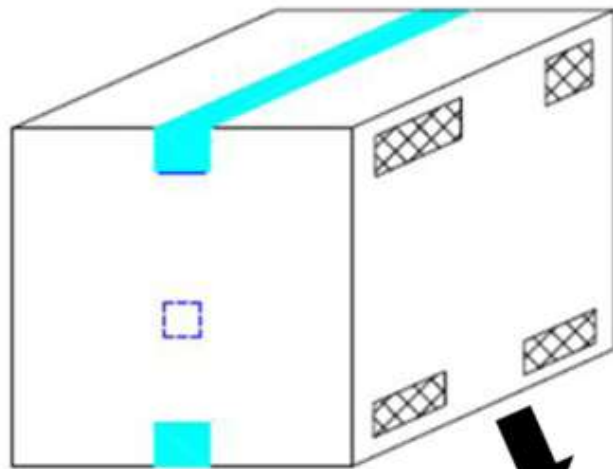

- L x W x H = 45cm x 38cm x 38cm

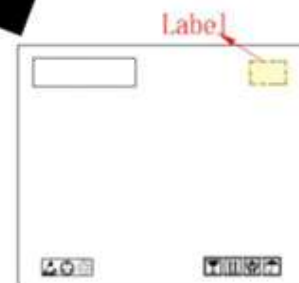

RECOMMENDED SOLDERING PROFILE:

Reflow Information:

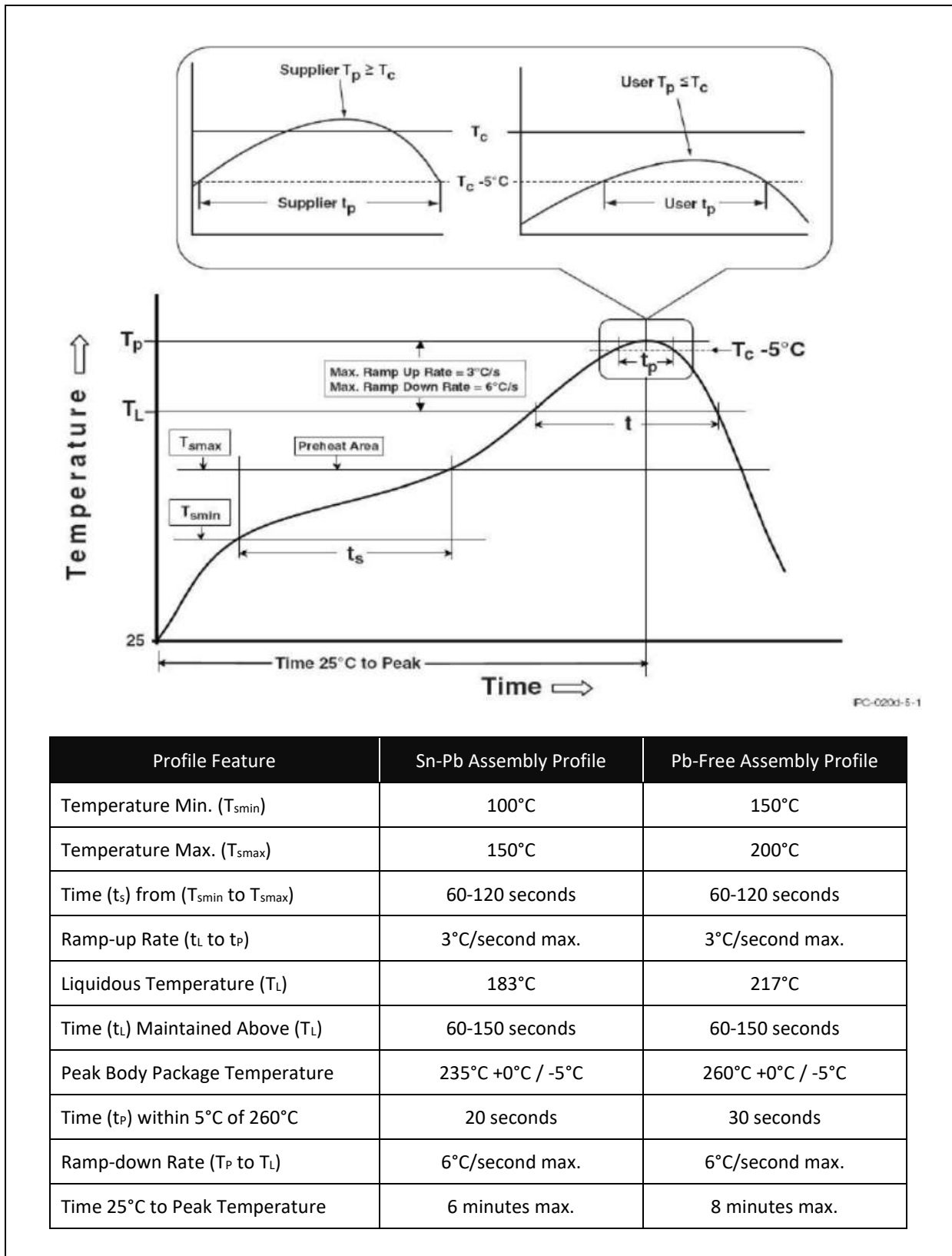

RECOMMENDED SOLDERING PROFILE:

Wave Soldering (JESD22-A111 Compliant):

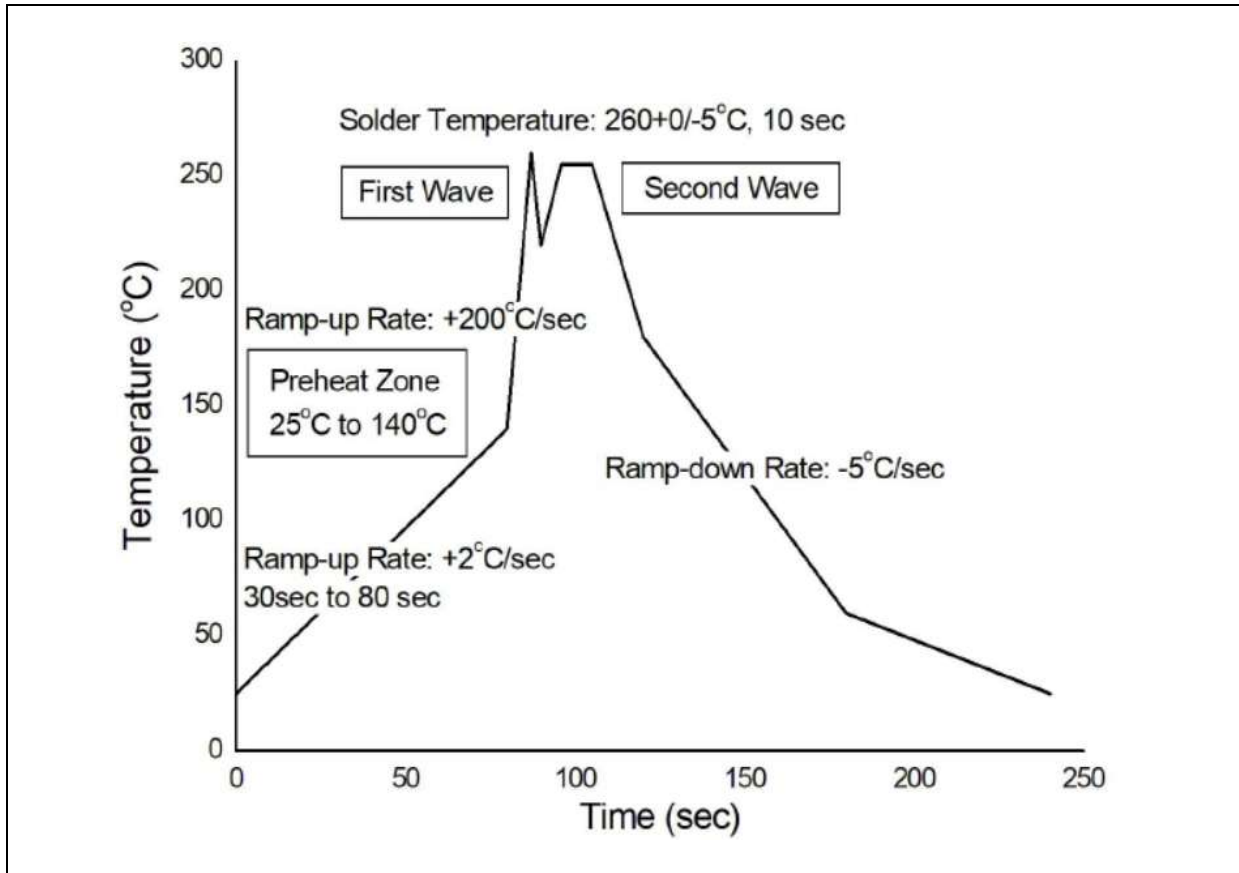

Hand Soldering:

Soldering Temperature	380±5°C
Soldering Time	3 sec max.

Note:

- One time soldering is recommended for all soldering methods.
- Do not solder more than three times for IR reflow soldering.