

Transfer or duplication of this document as well as the utilisation or communication of its content are not permitted unless express consent is granted. Violations give rise to claims for damages. All rights reserved in case of patent, utility model or design patent registrations.

Weitergabe sowie Vervielfältigung dieses Dokuments, Verwertung und Mitteilung seines Inhalts sind verboten, soweit nicht ausdrücklich gestattet. Zuwiderhandlungen verpflichten zu Schadensersatz. Alle Rechte für den Fall der Patent-, Gebrauchsmuster- oder Designeintragung vorbehalten.

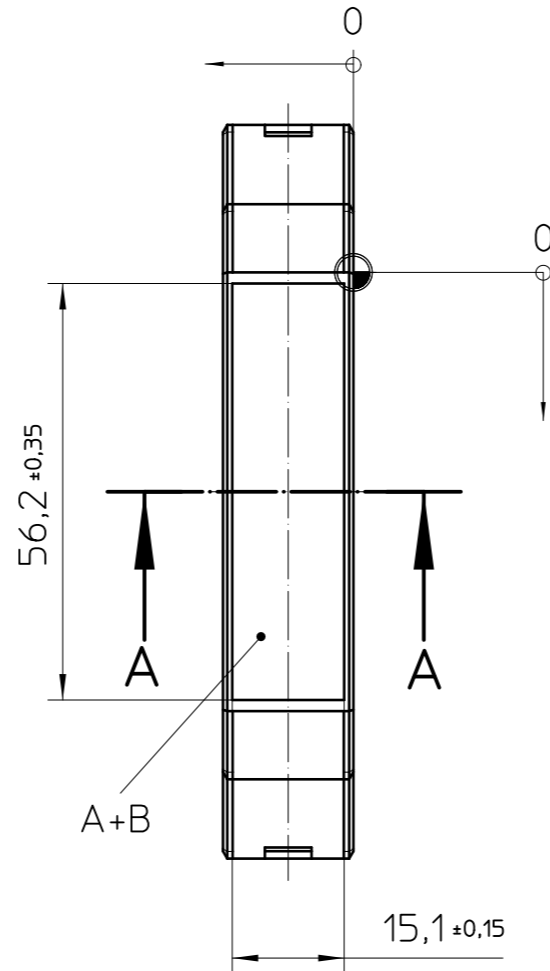
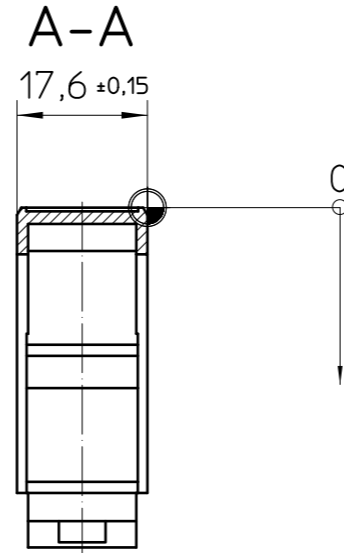
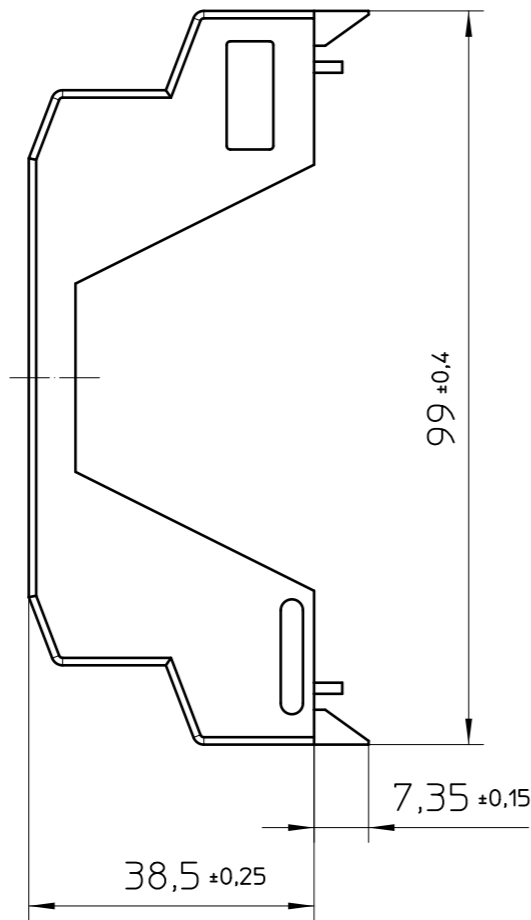
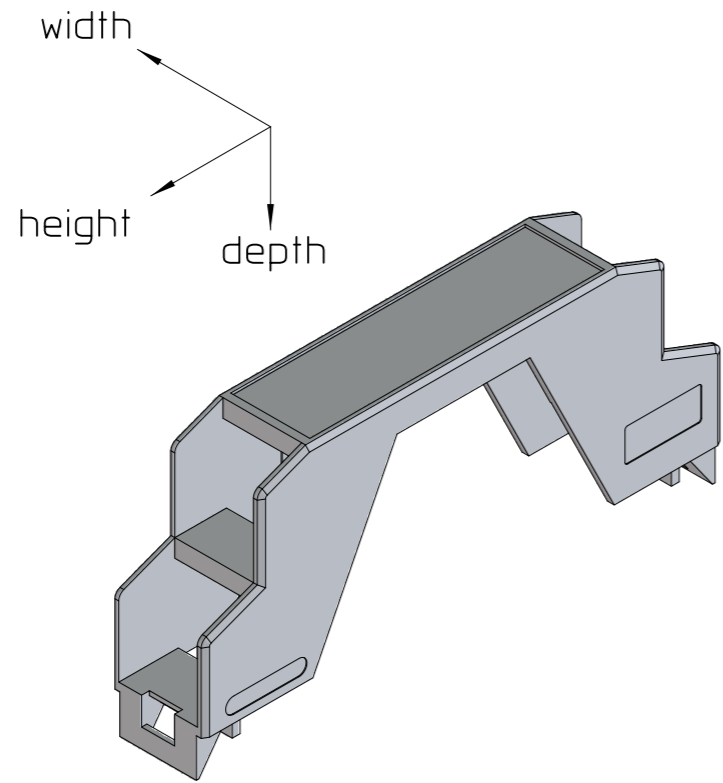

General Information:

- Simplified representation, exemplary shown in gray.
- Document excluded from change process
- Units are in millimeters [mm] and degrees [°]
- Tolerances apply in a normal climate according to DIN EN ISO 291-23/50-2, PA plastic parts with about 2% (% by weight) moisture content.
- Workpiece zero point for mechanical processing
- Tolerances for mechanical processing are ISO 2768-mK
- Tolerances for printing DIN ISO 2768-m
- Machining radii min. R1, further on request
- Web: www.phoenixcontact.com webcode: #xxxx

Additional Information:

- A. Marking area
- B. Machining area

DIN A3 	document-No. / RI	date	scale
	00847688 / 02	27.01.2026	1:1
ident.-No.	document-type	description	
2906827	TECDCO 2D_Productdrawing		
page 1 of 1	ME 17,5 OT-MSTBO GN		