

Connectors for multi-couplings

DuraDock multi

EN



STÄUBLI ELECTRICAL CONNECTORS

Connections for Life



Stäubli, as the international technology leader, offers innovative mechatronics solutions in its four divisions: Electrical Connectors, Fluid Connectors, Robotics, and Textile. At Stäubli Electrical Connectors, we develop advanced connection solutions based on the reliable MULTILAM contact technology.

Together for reliable and safe connections

We know that you entrust us with the functionality of your applications and we work hard to ensure this every single day. Thanks to our high level of expertise, our extensive experience and the multiple successful co-operation with our partners, numerous new developments have originated at Stäubli Electrical Connectors and subsequently have become worldwide standards. This includes our MC4 connector portfolio for which we are today the global market

We create connections for life – and our customers are at the center of these connections. We are convinced that solid and stable partnerships directly contribute to our mutual success.

We take on the needs of our partners and deal with the most extraordinary challenges. As a result, we always create, sell and

support reliable and long-lasting products for markets with the highest productivity and safety requirements in close cooperation with our customers.

leader in photovoltaic. As the Stäubli original, the MC4 represents the result of our constant quest for innovation, quality and safety.

Further examples are the CombiTac modular connector system or the Quick Charging Connector (QCC) for automatic charging systems.

We ensure connections for life together with our long-standing customers in a wide range of industries from renewable energies, power transmission and distribution and E-mobility to industrial automation applica-

tions, railway and welding automation, test and measurement and medical devices.

Thus, developing reliable, efficient and safe solutions based on our proven MULTILAM contact technology, which guarantees a high service lifetime in addition to highly efficient power transmission.

Applications and benefits



Stäubli's multipole connectors are used in docking systems, tool changers, and in manually or automatically operated multi-couplings.

Our solutions are ideal for a wide range of standard industrial applications, as well as other highly demanding applications where reliability is of the essence.

- Unparalleled contact reliability thanks to MULTILAM advanced contact technology
- Robust, reliable and user-friendly – up to 1 million mating cycles
- High current-carrying capacity with minimal contact resistance for a long lifespan
- Many possible combinations to work with almost any application, from data transmission to high-current applications
- Our standard program covers cable cross-sections of up to 50 mm² (AWG 1/0), currents up to 200 A and up to 72 poles

Content

Page 7	Introduction <ul style="list-style-type: none"> • Technical data • Assembly principle • Installation situation • Combination possibilities • Connector selection • Overview of products • Contact carrier • Housings • Plugging frequency test • Footprints • Insertion and withdrawal force 	Page 60	Contact insert sets <ul style="list-style-type: none"> • Overview • Signal • Hybrid • Power • High Current • Special contact insert sets (CR + SIL) • PEEK
Page 26	Contacts <ul style="list-style-type: none"> • Overview • Signal • Thermocouple pressure contacts • BUS • Hybrid • Power • High Current • PEEK 	Page 74	Housings <ul style="list-style-type: none"> • Overview • Shielding principle • Plastic housings • Special pin and socket housings • Housing front parts • Plastic housings, shielded, insulated • Metal housing, shielded • Metal housing
Page 48	Contact carriers <ul style="list-style-type: none"> • Overview • Signal • BUS • Hybrid • Power • High Current • Special contact carriers (CR + SIL) • PEEK 	Page 86	Assembly tools
		Page 88	Accessories
		Page 90	Appendix <ul style="list-style-type: none"> • Installation situation • Outer dimensions • Drilling plans • Derating-diagrams • Index

General information

Colour code

For those items available in various colours, replace the asterisk “*” with the appropriate colour code.

20	green-yellow	26	violet
21	black	27	brown
22	red	28	grey
23	blue	29	white
24	yellow	33	transparent
25	green		

Changes / Provisos

All data, illustrations and drawings in the catalogue have been carefully checked. They are in accordance with our experience to date, but no responsibility can be accepted for errors.

We also reserve the right to make modifications for design and safety reasons. When designing equipment incorporating our components, it is therefore advisable not to rely solely on the data in the catalogue but to consult us to make sure this information is up to date. We shall be pleased to advise you.

Copyright

The use of this catalogue for any other purpose, in whatever form, without our prior written consent is not permitted.

RoHS

European Directive 2011/65/EU incl. all related amendments (e.g. Delegated Directive (EU) 2015/863)

For further information please follow the link below

www.staubli.com/de/en/electrical-connectors/downloads/certificates/material-compliance.html

Symbols



Accessories or special tools exist for this product

www.staubli.com/electrical



The assembly instruction MA000 is available for this product

www.staubli.com/electrical

UNLIMITED POSSIBILITIES FOR CONTACT SOLUTIONS

MULTILAM Technology



MULTILAM are specially formed and resilient contact elements. All Stäubli Electrical Connectors products benefit from the unique and outstanding performance of the **MULTILAM Technology**.

Thanks to their constant spring pressure, MULTILAM louvers ensure continuous contact with the contact surface, resulting in a constantly low contact resistance.

MULTILAM Technology allows to find solutions for connectors within the severest constraints and in certain products for up to 1 million mating cycles.

This makes the MULTILAM Technology the best choice for applications with demanding requirements:

- Reliable and longlife operation due to constantly high performance
- Safe operation under highest environmental demands on temperature, vibration and shock
- Particularly suitable for high current connectors, but also for data and signal contacts as well as for high voltage connections
- Automated solutions with a high number of mating cycles

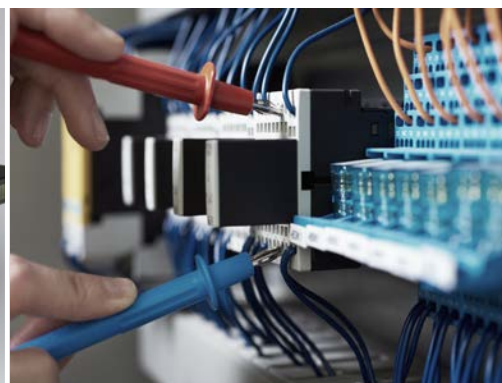

INTRODUCTION

Technical data

The contacts are equipped with a crimping sleeve. In the unplugged condition the complete socket and pin parts are longitudinally waterproof over the contacts. The use of plastic housings eliminates the need for earthing, thus simplifying the work of assembly.

When using metal housings, the housings must be earthed using a protective conductor according to IEC 60364-4-41.

Note:

The housings may not be used as mechanical centering. For safe operation and correct alignment of plates stable guiding pins are mandatory.

Technical data	
Contact system	MULTILAM
Rated voltage	max. 830 V
Rated current (Derating diagrams, page 95)	max. 200 A
Overvoltage category Pollution degree	CATIII 3 ¹⁾
Test voltage	0,84 kV – 3,31 kV/50 – 60 Hz/1 min.
Insulation coordination according to IEC 60664-1, DIN VDE 0110-1	4 kV: 3 V – 300 V 6 kV: 3 V – 630 V
Temperature resistance contact carriers	NBR: -30 °C...+100 °C CR: -40 °C...+100 °C SIL: -40 °C...+150 °C PK: -40 °C...+150 °C TPE: -20 °C...+90 °C
Operating temperature (Plastic housing) (Metal housing)	-10 °C...+90 °C -40 °C...+150 °C
Storage temperature	-40 °C...+80 °C
Degree of protection, mated (DIN 40050) MGK..., MGS... mated (DIN 40050) MGA... unmated (Socket side)	IP65 IP67 IP2X ²⁾
Safety class	II ¹⁾
Number of poles	2+PE – 70+2PE
Nominal-Ø contact	1 mm – 11 mm
Conductor cross section	0.14 mm ² – 50 mm ² 26 AWG – 1/0 AWG
Type of connection	Crimping
Contact material	CuZn alloy; silver or gold plated
Carrier material	NBR/CR/SIL/PEEK
Housing material	Metal/POM or PA
Shielding (360°)	Available (G1 – G3)
For further instructions	EN 60664-1/2008-01 DIN VDE 0627/EN 61984/2009-11 DIN VDE 0298-4/2003-08

¹⁾ Except PEEK (Pollution degree 2)

²⁾ Except PEEK 19.6660, 19.6658, 19.6654 & 19.6626

Assembly principle

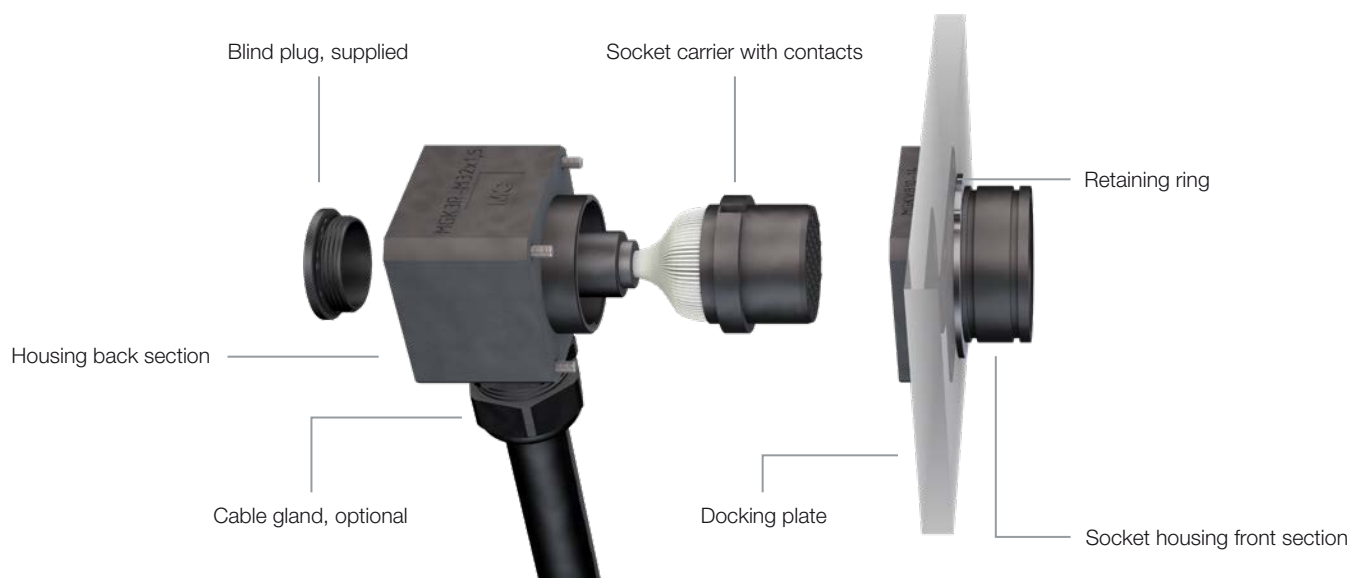

Installation situation

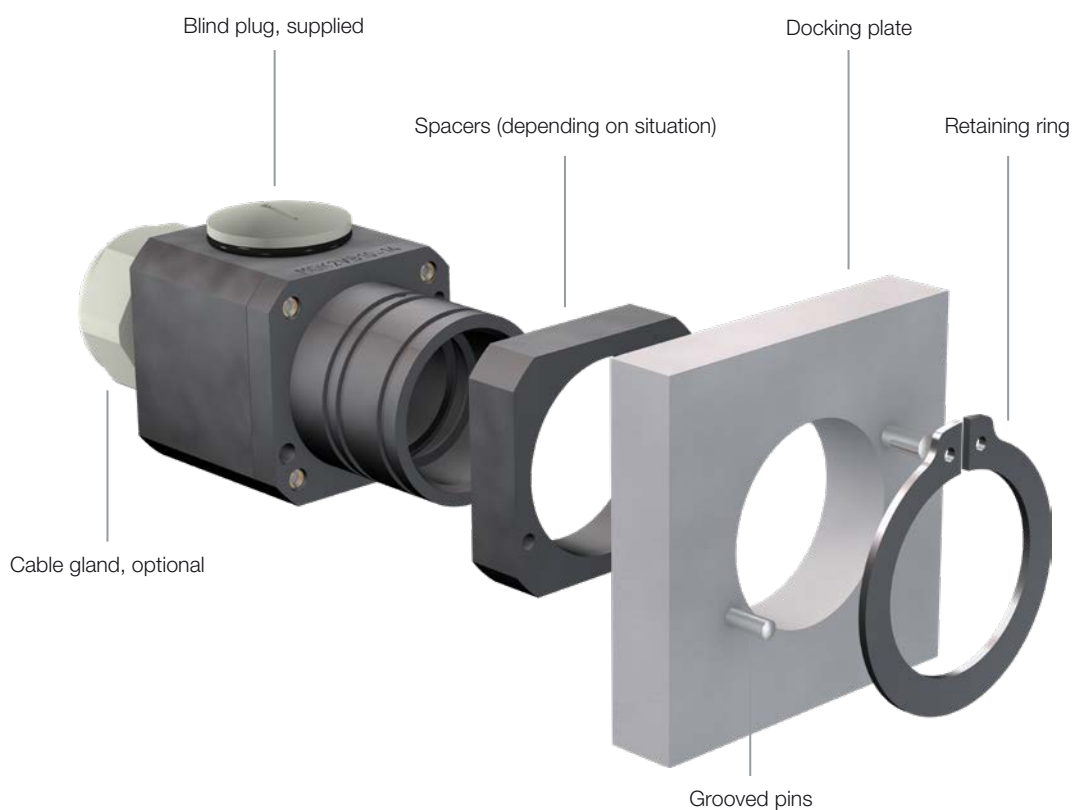

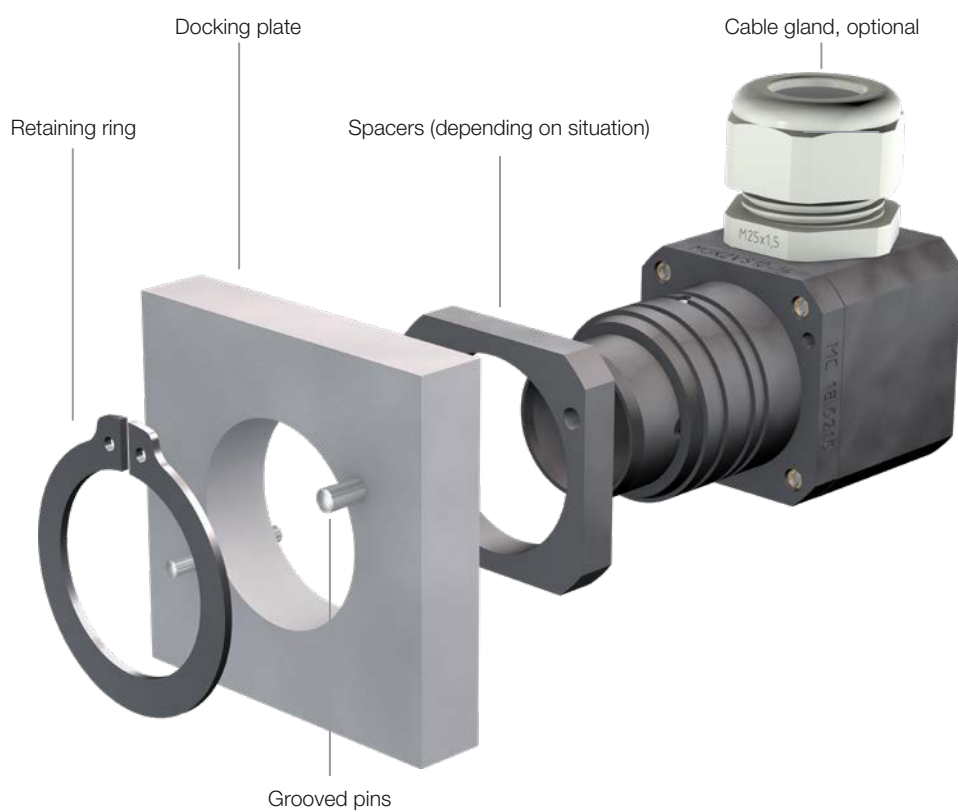
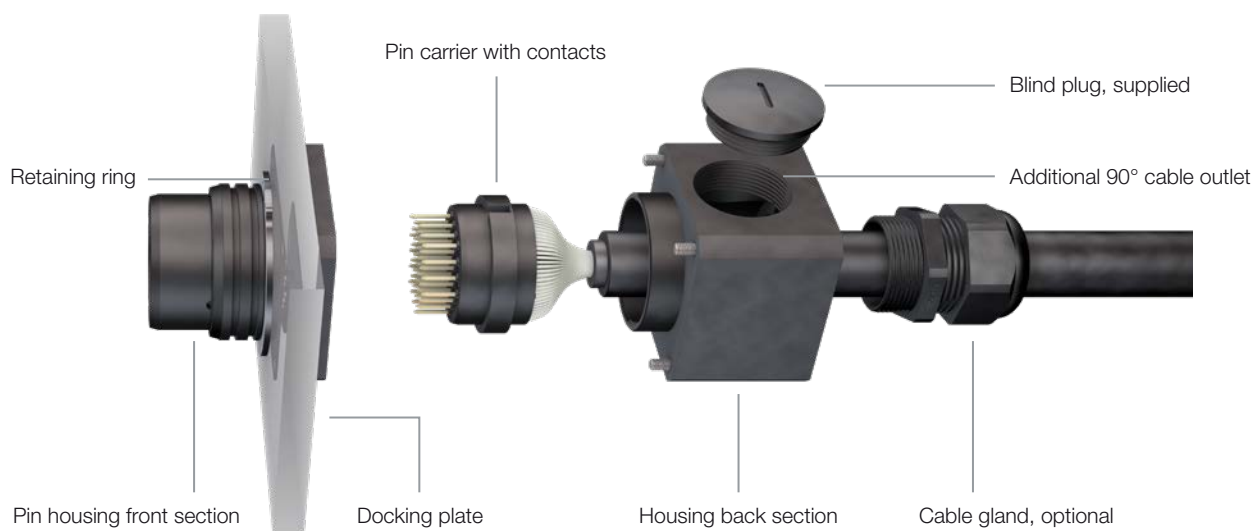

Combination possibilities

Size G1

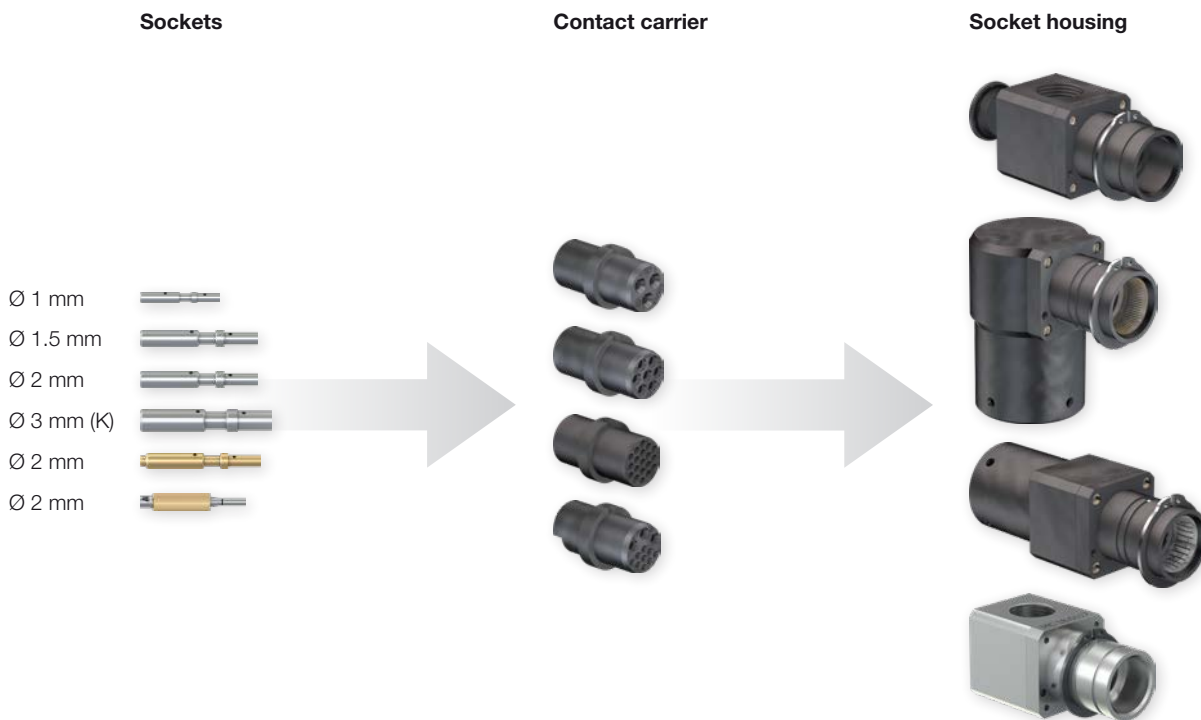

Size G2

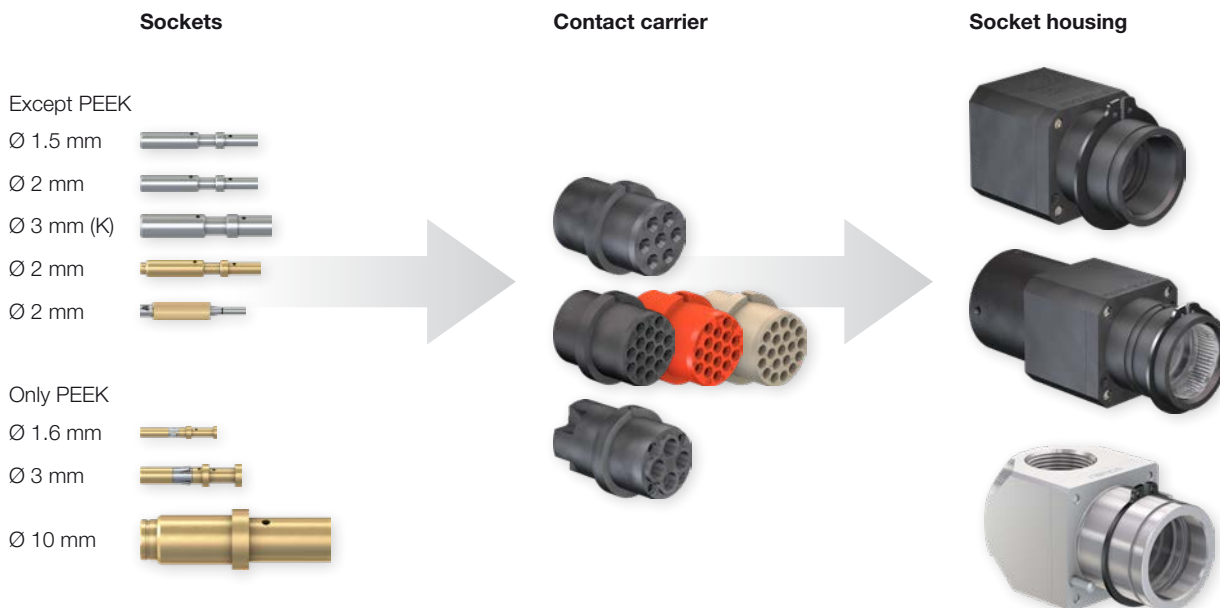

Note:

In case insulators do not exist with the exact pole count:

- pick an insulator with more poles than needed

- close the empty contact chambers with blind plugs (page 88).

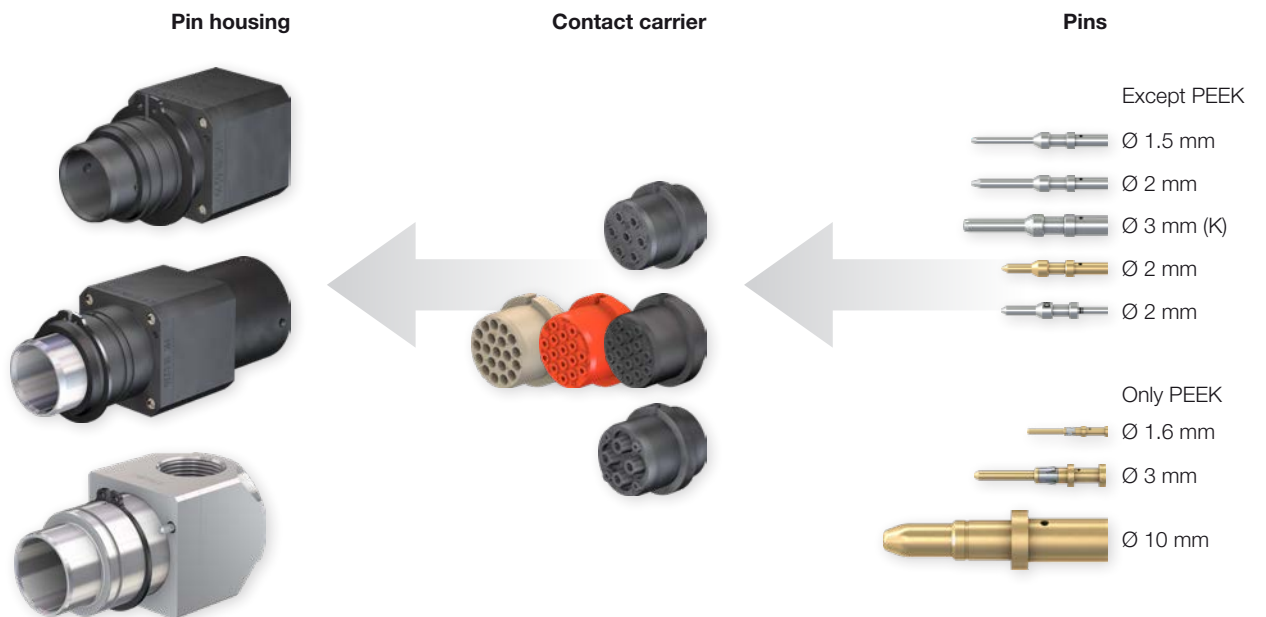
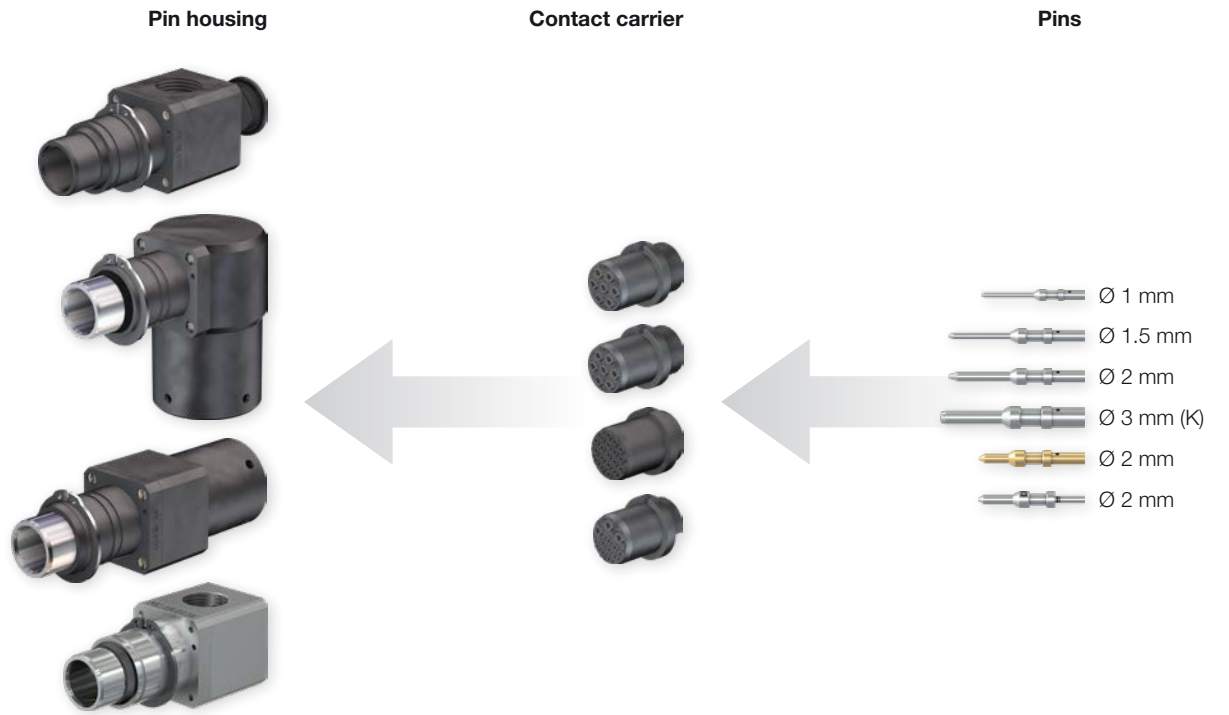

Size G3

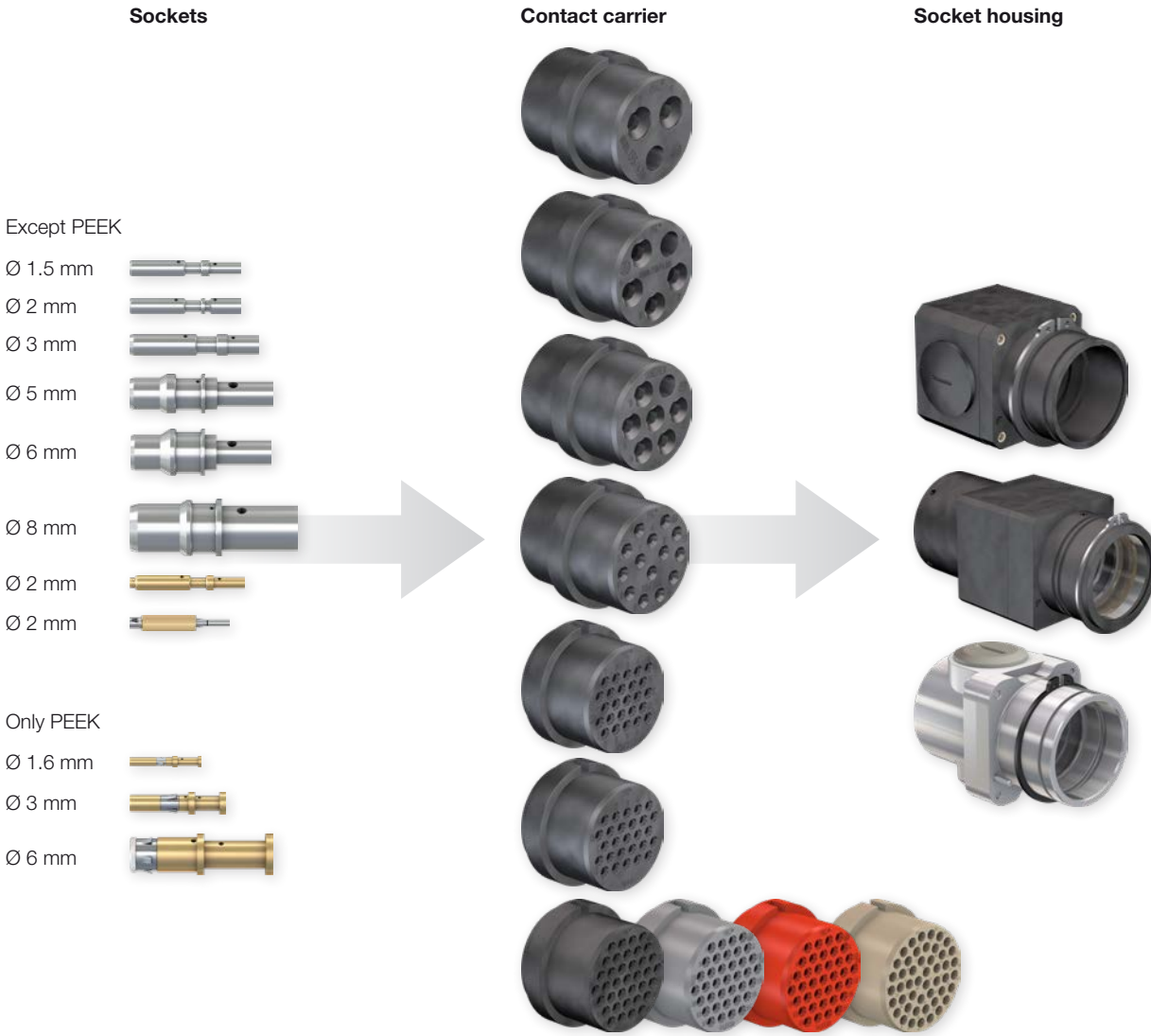

Size G4

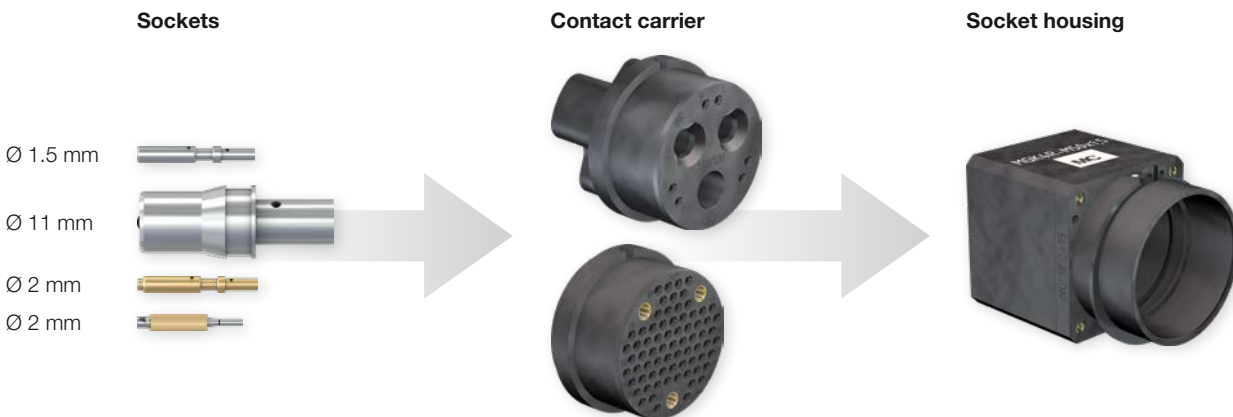

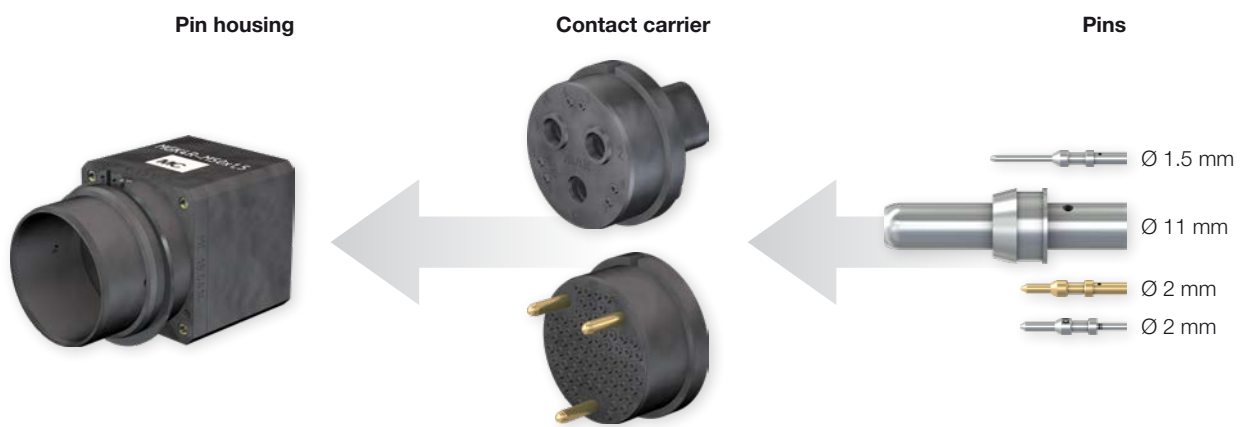
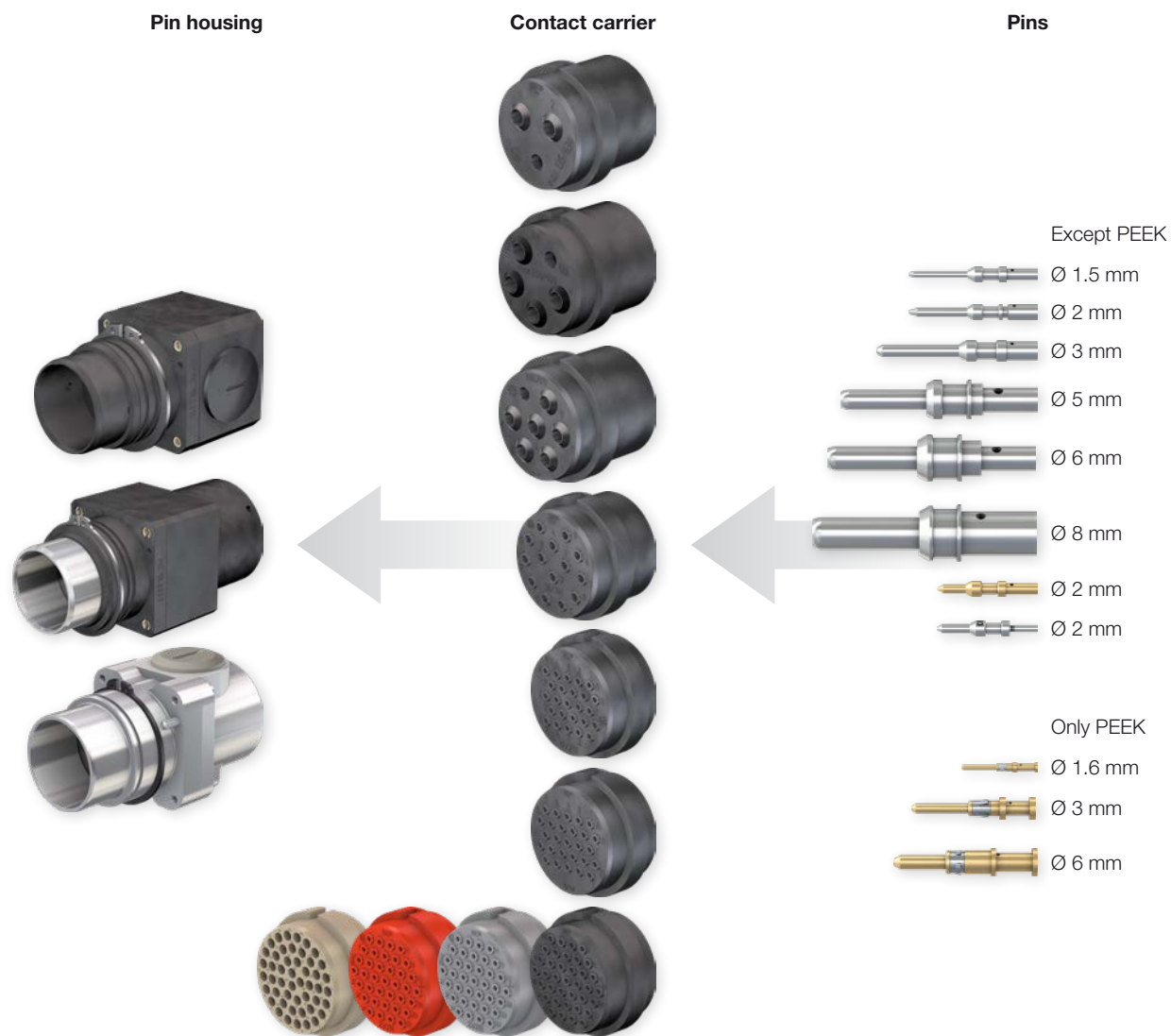

Connector selection

Select application and contacts

Step

1

Signal		
Standard	Thermocouple pressure contacts	Pressure contacts
0.14 mm ² – 1.5 mm ² 1 A – 16 A Page 28	0.14 mm ² – 0.5 mm ² Page 30	0.5 mm ² – 1.5 mm ² 2 A – 10 A Page 32

BUS
Standard
0.14 mm ² – 1.5 mm ² 1 A – 16 A Page 34

Hybrid	
Standard	Short version
0.14 mm ² – 50 mm ² 1 A – 200 A Page 36	2.5 mm ² – 4 mm ² 20 A – 32 A Page 36

Power	
Standard	Short version
0.5 mm ² – 4 mm ² 10 A – 36 A Page 40	2.5 mm ² – 4 mm ² 20 A – 32 A Page 40

High Current
Standard
6 mm ² – 50 mm ² 50 A – 200 A Page 42

PEEK
Standard
0.15 mm ² – 70 mm ² 5 A – 200 A Page 46

Select contacts carriers

Step

2

Synthetic rubber (NBR)		
Signal	BUS	Hybrid
2+PE – 70+2PE 25 V – 630 V Page 50	6+PE – 70+2PE 25 V – 250 V Page 52	2+PE+9 – 70+2PE 25 V – 630 V Page 53
Power	High Current	
2+PE – 36+PE 250 V – 400 V Page 54	2+PE – 6+PE 25 V – 630 V Page 55	

Chloroprene (CR)	Silicone (SIL)	PEEK (PK)
36+PE 250 V Page 56	3+PE+4, 6+PE, 15+PE, 36+PE 250 V Page 57	1 – 47+PE 150 V – 600 V Page 59

Select housings

Step

3



























Plastic		
Standard	Insulated, shielded	Specials
Page 76	Page 80	Page 78

Metal	
Shielded	Standard
Page 83	Page 84

Form shroud
Page 79

Overview of products

Contacts

						Carrier size			
						G1			
Conductor cross section		Nom.-Ø contact	Max. rated current	Mating cycles	250 V	250 V	250 V	150 V	
mm ²	AWG	mm	A		2+PE	2+PE+9	6+PE	18+PE	
0.14 – 0.5	26 – 20	Ø 1.5	 1 – 10	1,000,000			●		
0.5 – 1.5	20 – 16	Ø 1.5	 10 – 16	1,000,000		●	●		
		Ø 1.6	 16	10,000					
		Ø 2	 10 – 16	1,000,000				●	
1	18	Ø 1	 5	1,000,000				●	
2.5	14	Ø 2	 16	500,000					
2.5	14	Ø 2	 20	1,000,000					
2.5 – 4	14 – 12	Ø 3	 20 – 36	1,000,000	●				
2.5 – 6	14 – 10	Ø 3	 36 – 50	10,000					
6	10	Ø 5	 50	500,000					
		Ø 6	 50	500,000					
10	8	Ø 5	 63	500,000					
		Ø 6	 80	500,000					
		Ø 6	 80	10,000					
16	6	Ø 6	 90	500,000					
		Ø 6	 110	10,000					
25	4	Ø 6	 135	500,000					
		Ø 6	 135	10,000					
		Ø 8	 135	500,000					
		Ø 11	 135	500,000					
35	2	Ø 8	 150	500,000					
		Ø 10	 150	10,000					
35 – 38	~ 2	Ø 11	 170	500,000					
50	1/0	Ø 10	 180	10,000					
		Ø 11	 200	500,000					
70	2/0	Ø 10	 200	10,000					

Short version

2.5 – 4 (K)	14 – 12	Ø 3	 20 – 32	1,000,000	●			
-------------	---------	-----	---	-----------	---	--	--	--

Spring-loaded pressure contacts

Conductor cross section		Nom.-Ø contact	Max. rated current	Mating cycles	25 V
mm ²	AWG	mm	A		6+PE
0.5 – 1.5	20 – 16	Ø 2	 10 – 16	10,000	●

Thermocouple pressure contacts

0.14 – 0.5	26 – 20	Ø 2	< 1	100,000	●
------------	---------	-----	-----	---------	---

Note:

In case insulators do not exist with the exact pole count:

- pick an insulator with more poles than needed
- close the empty contact chambers with blind plugs (page 88).

When selecting the conductor cross-sections, please observe DIN VDE 0298-4, DIN EN 60204-1 and the derating diagrams, page 95.

Contact carrier

Our contact carriers in NBR material are available in four sizes. Carriers in silicone and chloroprene are also available. The use

of rubber material for these insulators allows a resilient mounting of the contacts in the carriers.

For demanding applications we are able to offer contact carriers in PEEK material in combination with special contacts.

Carrier size	Material				
	NBR	CR (Chloroprene)	SIL (Silicone)	PK (PEEK)	TPE
	-30 °C...+100 °C	-40 °C...+100 °C	-40 °C...+150 °C	-40 °C...+150 °C	-20 °C...+90 °C
G1	●				▨ (carrier color: black)
G2	●		●	●	
G3	●	●	●	●	
G4	●				

Housings

The standard plastic housings are available in four sizes. Additionally, shielded and insulated housings as well as metal housings can be provided for sizes 1 to 3. For size 3 and for applications where space is restrict-

ed, form shrouds are available as an alternative to cubic housing backs with cable glands (see page 79).

Housings with various threads are available for the installation of the cable glands.

Stäubli provides generally housings with metric threads, but also housings with PG and NPT threads.

Carrier size	Plastic	Shielded, insulated	Aluminum, shielded	Aluminum	Form shroud
	MGK...	MGS...-IS	MGS...-S	MGA...	MGK...-WST
G1	M20 ¹⁾ Pg13	M20 ²⁾ Pg13, Pg16	M20 Pg13	-	-
G2	M25 ¹⁾ Pg21	M25 ²⁾ Pg21	-	M25 Pg21 NPT3/4"	-
G3	M25, M32 ¹⁾ Pg21, Pg29	M32 ²⁾ Pg29	-	M32 + M40 Pg29 + Pg36 NPT1"	Axial + 90°
G4	M50 ¹⁾	-	-	On request	-

¹⁾ PA cable gland available as accessory (see page 88)

²⁾ Available with or without EMC cable gland

Plugging frequency test

Results of the plugging frequency test (i.e., reliability):

After over 1 million mating cycles, the multiple Stäubli connectors showed no significant

mechanical or electrical changes. The connectors tested proved reliable, without any loss of contact, up to 1,5 million cycles.

The mating cycle test is always carried out in a load-free state. The circuit is completed after the plugging operation and broken again before undocking.

Contact resistance R_k as a function of the number of mating cycles.

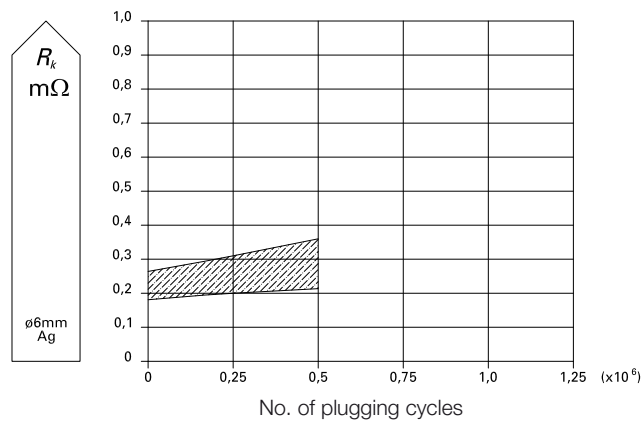
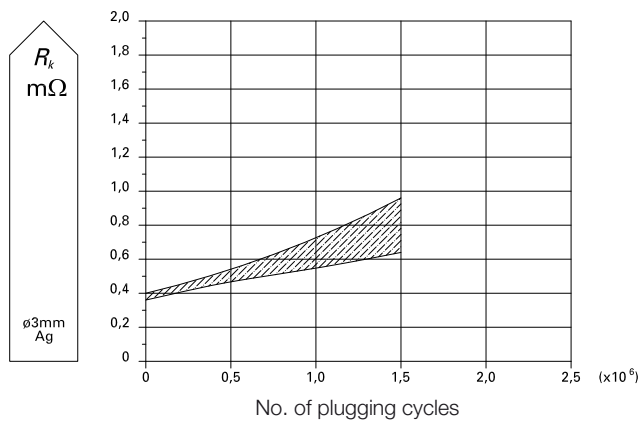
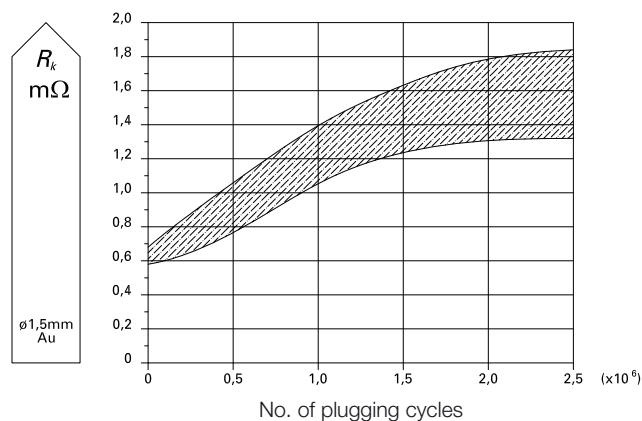
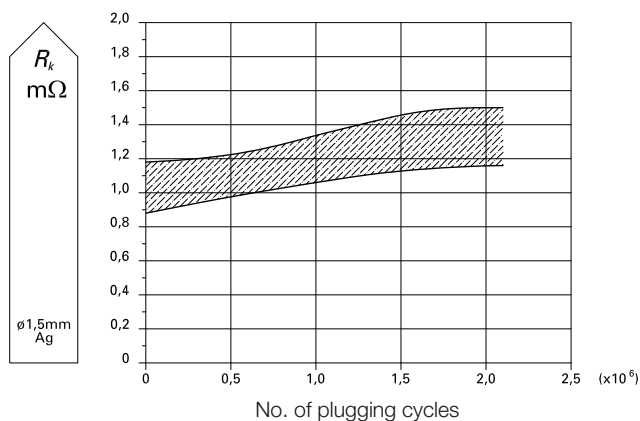

Contact resistance R_k is determined with the test configuration shown in ILL. 1 and calculation according to the equation:

$$R_k = \frac{\Delta U_k}{I}$$

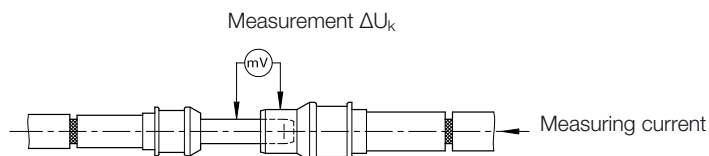

ILL. 1

Footprints

The pole diagrams show the male insulators (mating side, top view).

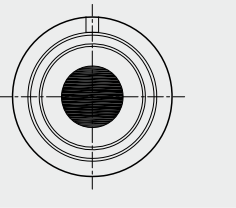
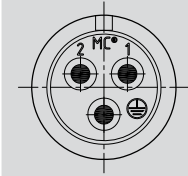
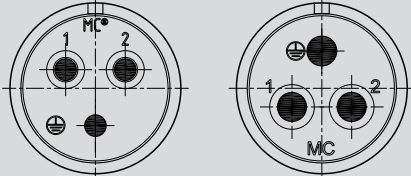
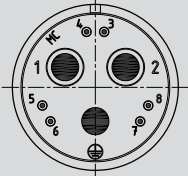
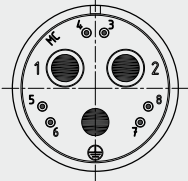
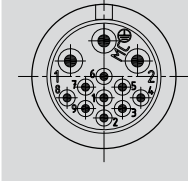
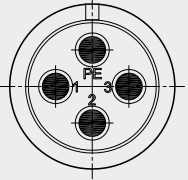
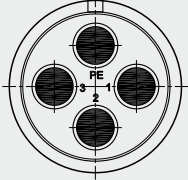
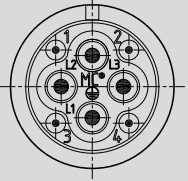
Number of poles	Carrier size			
	G1	G2	G3	G4
1	-		-	-
2+PE		-	Ø 6 mm Ø 8 mm 	
2+PE+6	-	-	-	
2+PE+9		-	-	-
3+PE	-			-
3+PE+4	-		-	-

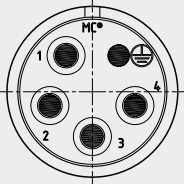
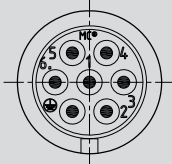
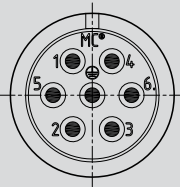
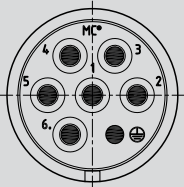
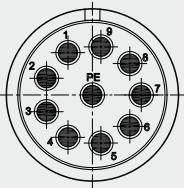
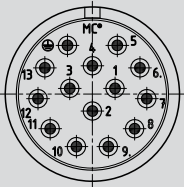
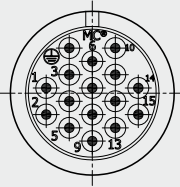
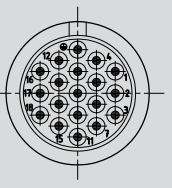
Number of poles	Carrier size			
	G1	G2	G3	G4
4+PE	-	-		-
6+PE	<p>2 variants (both plug-compatible): A: NBR material B: TPE material</p> 			-
9+PE	-	-		-
13+PE	-	-		-
15+PE	-		-	-
18+PE		-	-	-

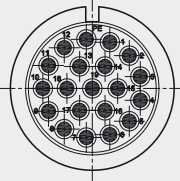
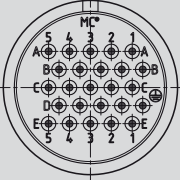
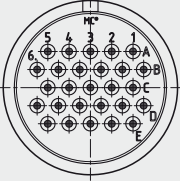
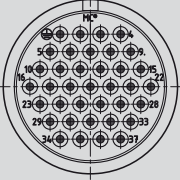
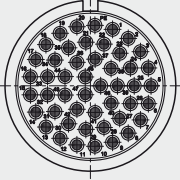
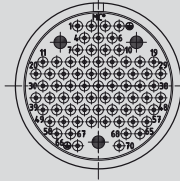
Number of poles	Carrier size			
	G1	G2	G3	G4
19+PE	-		-	-
24+PE	-	-		-
27	-	-		-
36+PE	-	-		-
47+PE	-	-		-
70+2PE	-	-	-	



We are a solution provider –
from the first concept to the final product

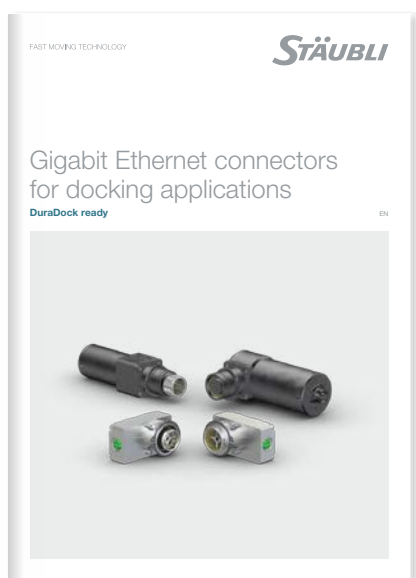

Gigabit Ethernet connectors
available in the document
„Gigabit Ethernet connectors for docking
applications“
see also www.staubli.com/electrical

Insertion and withdrawal force

The insertion and withdrawal forces depend on the number of poles and the surface characteristics of the contacts. The sliding

properties can be improved by the use of gold contacts.

Note:

The withdrawal force is smaller than the insertion force.

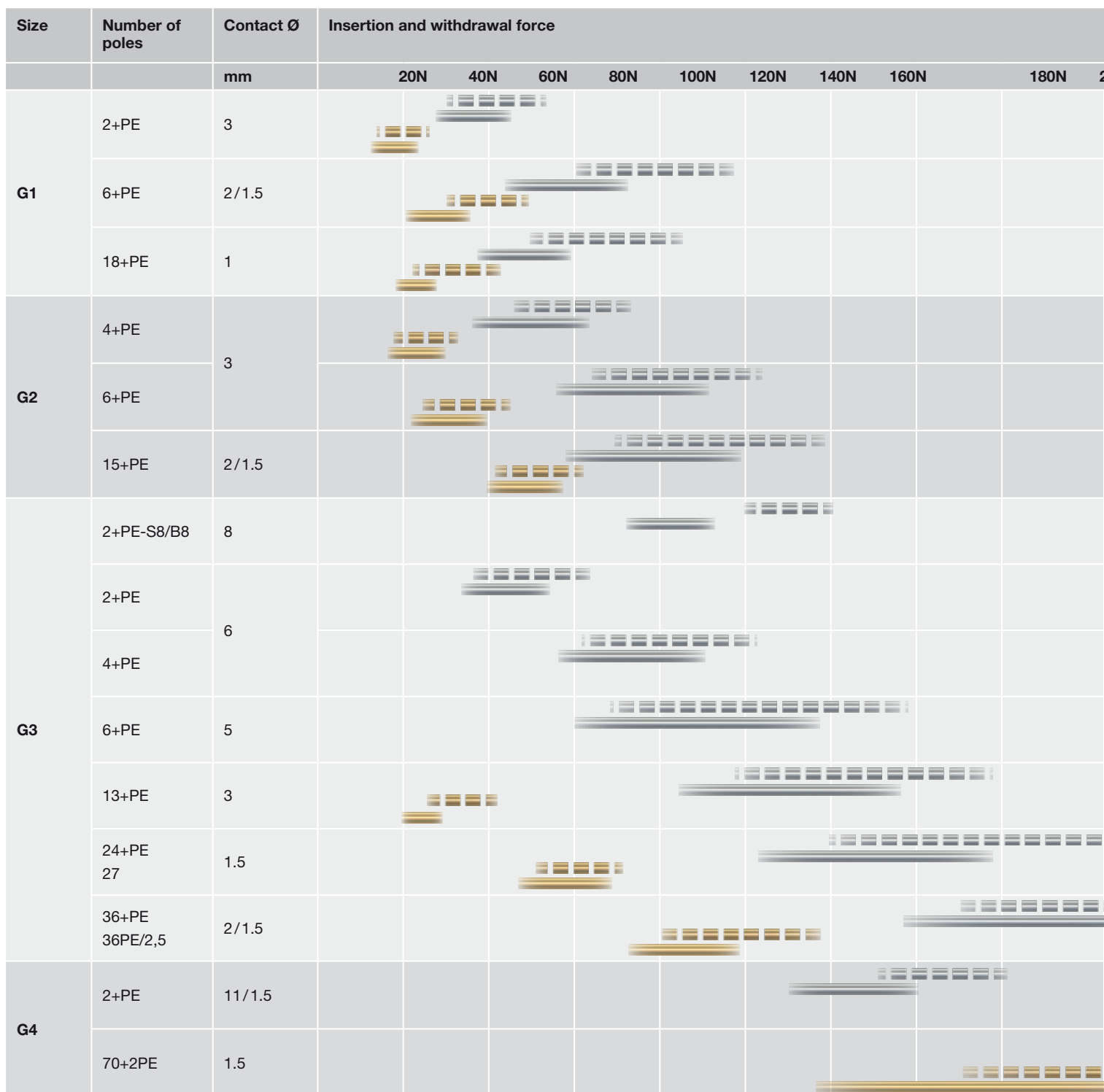

   Insertion force Au

 Withdrawal force Au



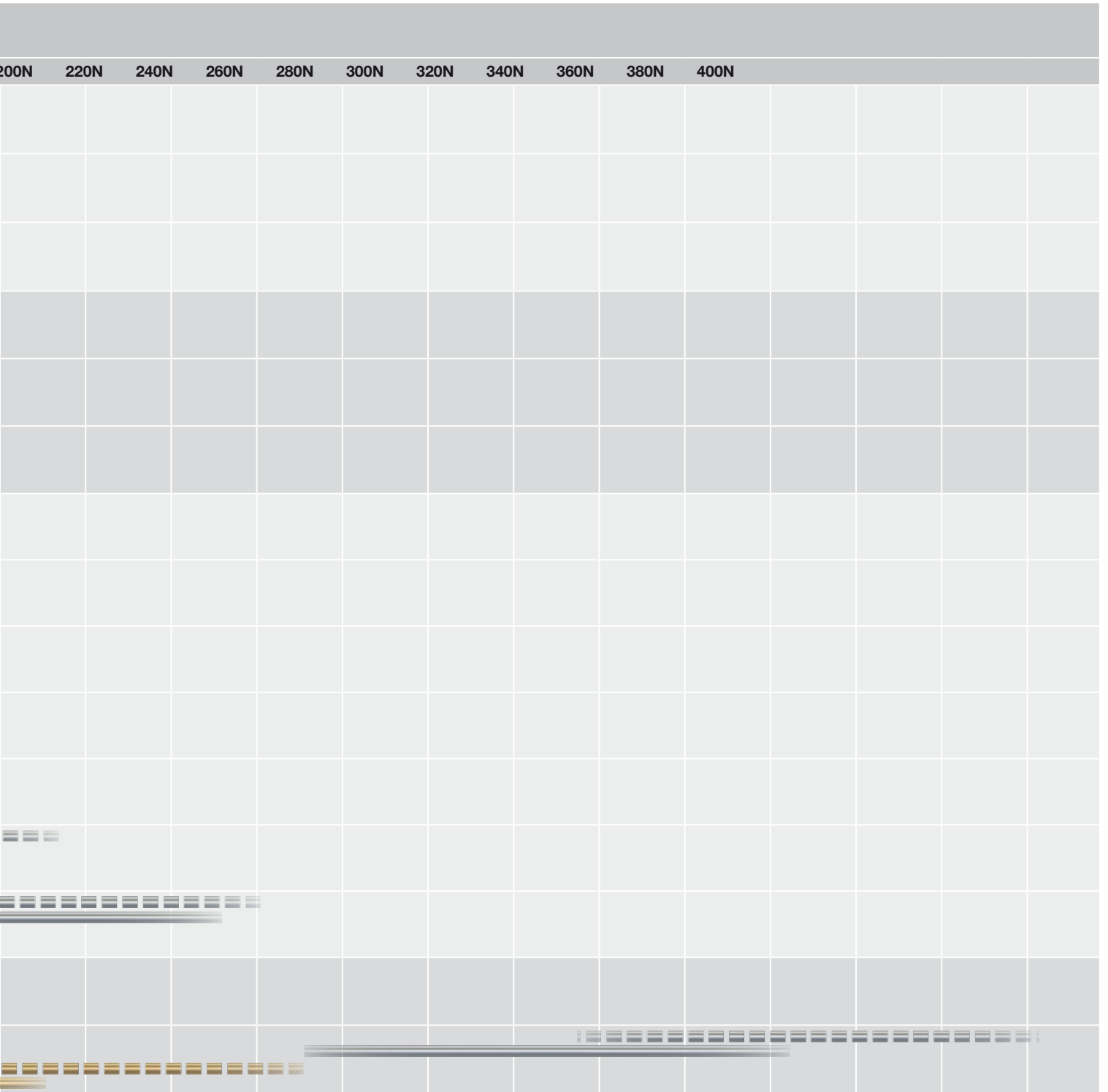

   Insertion force Ag



 Withdrawal force Ag

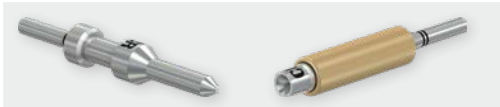
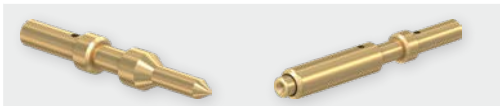

CONTACTS

Overview

	Conductor cross section ¹⁾		Nom.-Ø contact	Surface	Rated current	Mating cycles	Page	
	mm ²	AWG	mm		A	max.		
Signal applications								
		0.14 – 1.5	26 – 16	1 – 2		1 – 16	1,000,000	28
Thermocouple pressure contacts								
		0.14 – 0.5	26 – 20	2		Details see page 30	10,000	30
Pressure contacts								
		0.5 – 1.5	20 – 16	2		2 – 10	10,000	32
BUS applications								
		0.14 – 1.5	26 – 16	1 – 1.5		1 – 16	1,000,000	34

	Conductor cross section ¹⁾		Nom.-Ø contact	Surface	Rated current	Mating cycles	Page
	mm ²	AWG	mm		A	max.	

Hybrid applications

	0.14 – 50	26 – 1/0	1 – 11		1 – 200	500,000 – 1,000,000	36
--	-----------	----------	--------	--	---------	---------------------------	----

Power applications

	0.5 – 4	20 – 12	2 – 3		10 – 36	500,000 – 1,000,000	40
--	---------	---------	-------	--	---------	---------------------------	----

High Current applications

	6 – 50	10 – 1/0	5 – 11		50 – 200	500,000	42
--	--------	----------	--------	--	----------	---------	----

PEEK applications – on request –

	0.5 – 70	20 – 2/0	1.6 – 10		5 – 200	10,000	46
--	----------	----------	----------	--	---------	--------	----

Contacts for Signal applications

Standard version

Contacts for the transmission of signal currents between 1 A and 16 A for cable cross-sections of 0.14 mm² to 1.5 mm².

They are either silver plated (Ag) or gold plated (Au) and every socket is provided with the tried and tested MULTILAM.

These contacts can then be used in different types of contact carriers (up to 72 poles).

Important:

Empty contact cavities must be fitted with blind plugs. If the cavities are only partly occupied, care must be taken to distribute

the contacts evenly in the carrier; this way, connectors remain longitudinally waterproof and carriers do not get deformed.

Mating cycles: max. 1,000,000



Conductor cross section ¹⁾		Nom.-Ø contact	Surface	Order No.	Type	Max. rated current ²⁾
mm ²	AWG	mm				A
0.14 – 0.5	26 – 20	1.5		18.9024 18.8024	SP1.5/0.14-0.5 BP1.5/0.14-0.5	1 – 10
				18.9025 18.8025	SP1.5/0.14-0.5 AU BP1.5/0.14-0.5 AU	
0.2 – 1	24 – 18	1		18.9002 18.8002	SP1/1 BP1/1	2 – 5
				18.9003 18.8003	SP1/1 AU BP1/1 AU	
0.5 – 1.5	20 – 16	1.5		18.9004 18.8004	SP1.5/0.5-1.5 BP1.5/0.5-1.5	10 – 16
				18.9005 18.8005	SP1.5/0.5-1.5 AU BP1.5/0.5-1.5 AU	
0.5 – 1.5	20 – 16	2		18.9008 18.8008	SP2/0.5-1.5 BP2/0.5-1.5	10 – 16
				18.9009 18.8009	SP2/0.5-1.5 AU BP2/0.5-1.5 AU	

¹⁾ If the number of contacts is > 2, when selecting the conductor cross-sections observe DIN VDE 0298-4, DIN EN 60204-1 and the derating diagrams, page 95

²⁾ Dependent on conductor cross section







Assembly tools, page 86



Assembly instructions MA202

www.staubli.com/electrical

For appropriate carrier size on page 50					Blind plug
G1	G2	G3	G4		
6+PE	15+PE	24+PE / 27 / 36+PE	70+2PE	18.5500 	
18+PE	–	–	–	18.5506 	
6+PE	3+PE+4 15+PE	24+PE / 27 / 36+PE	70+2PE	18.5500 	
6+PE	15+PE	–	–	18.5500 	

Type code example:

SP2/0,5 – 1,5 AU

SP2/0,5 – 1,5 AU	SP: Pin; BP: Socket
SP2/0,5 – 1,5 AU	Nom.-Ø pin (mm)
SP2/0,5 – 1,5 AU	Conductor cross section (mm ²)
SP2/0,5 – 1,5 AU	Surface

Contacts for Signal applications

Thermocouple pressure contacts

Thermocouple allows for the precise measurement of temperatures. Between two wires of different materials a voltage is generated that varies according to the rise in temperature.

The electrical measurement of temperature requires that the entire measurement chain (temperature sensor, cable connection points) consists of the same combination of materials. Using a uniform material prevents thermal imbalances in the case of the

connection of two parts with the same initial temperature.

With Stäubli thermocouple contacts, you can extend the measurement chains or lay them out as plug contact connections.

There are several types of thermocouples made from different materials adapted to the measured temperature range.

Stäubli thermocouple pressure contacts are available for 5 different types of sensor: E, J, K, N, and T. For that reason, Stäubli has

developed different types of spring loaded contacts for thermocouples from the 7 most commonly used alloys: NiCr, NiAl, NiCrSi, NiSi, CuNi, Fe, Cu.

Stäubli thermocouple pressure contacts can be built into standard contact carriers.

Mating cycles: max. 100,000

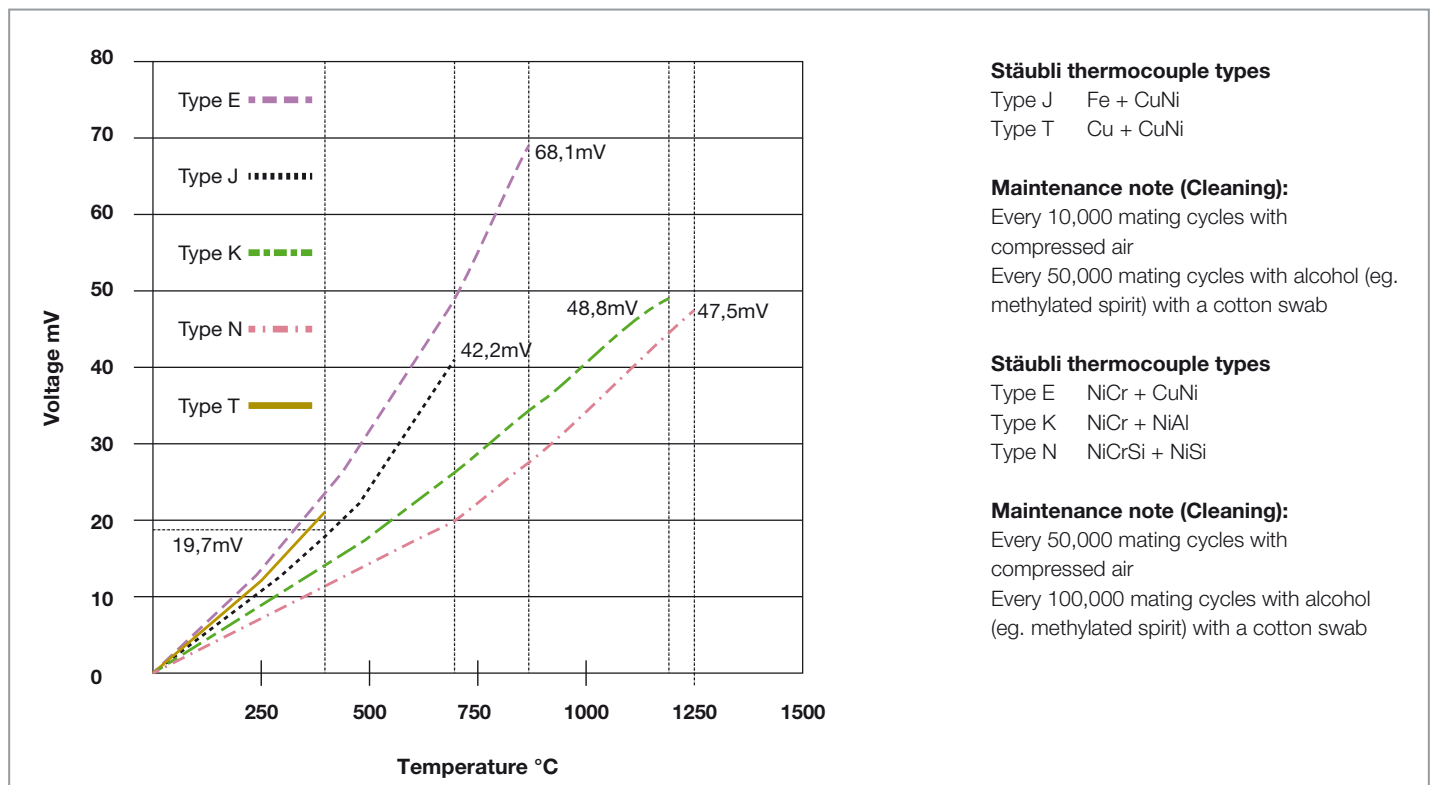

Stäubli thermocouple types

Type J Fe + CuNi
Type T Cu + CuNi

Maintenance note (Cleaning):

Every 10,000 mating cycles with compressed air
Every 50,000 mating cycles with alcohol (eg. methylated spirit) with a cotton swab

Stäubli thermocouple types

Type E NiCr + CuNi
Type K NiCr + NiAl
Type N NiCrSi + NiSi

Maintenance note (Cleaning):

Every 50,000 mating cycles with compressed air
Every 100,000 mating cycles with alcohol (eg. methylated spirit) with a cotton swab



Assembly instructions MA202

www.staubli.com/electrical

Description according to: IEC 60584-1

To ensure clear identification, our thermocouple pressure contacts are provided with different grooves and markings.

Cu
Copper (without groove)



Fe
Iron (without groove)



NiAl
Alumel® (1 groove)



NiCr
Chromel® (2 grooves)



NiSi
Nisil (3 grooves)



NiCrSi
Nicrosil (4 grooves)



CuNi
Constantan® (1 wide groove)



Material marking

Groove

Contacts for Signal applications

Thermocouple pressure contacts



Conductor cross section		Nom.-Ø contact	Surface	Order No.	Type	Contact pressure ¹⁾
mm ²	AWG	mm				N
0.14 – 0.5	26 – 20	2	NiSi	19.6723	DSP2-NISI/0,14-0,5	6 – 9
				19.6724	DBP2-NISI/0,14-0,5	
0.14 – 0.5	26 – 20	2	NiCrSi	19.6721	DSP2-NICRSI/0,14-0,5	6 – 9
				19.6722	DBP2-NICRSI/0,14-0,5	
0.14 – 0.5	26 – 20	2	Cu	19.6725	DSP2-CU/0,14-0,5	6 – 9
				19.6726	DBP2-CU/0,14-0,5	
0.14 – 0.5	26 – 20	2	Fe	19.6719	DSP2-FE/0,14-0,5	6 – 9
				19.6720	DBP2-FE/0,14-0,5	
0.14 – 0.5	26 – 20	2	CuNi	19.6717	DSP2-CO/0,14-0,5	6 – 9
				19.6718	DBP2-CO/0,14-0,5	
0.14 – 0.5	26 – 20	2	NiAl	18.9062	DSP2-AL/0,14-0,5	6 – 9
				18.8062	DBP2-AL/0,14-0,5	
0.14 – 0.5	26 – 20	2	NiCr	18.9063	DSP2-CR/0,14-0,5	6 – 9
				18.8063	DBP2-CR/0,14-0,5	

Spring-loaded pressure contacts



Stäubli pressure contacts consist of a rigid contact pin and a resilient contact socket equipped with the tried and tested MULTILAM. For use in standard contact carriers. Pressure

contacts are used in docking systems with short stroke distances (approx. 6 mm) or in combination with standard plug contacts for switching functions. Stäubli pressure contacts

are made from brass and gold plated. The wire termination is effected by crimping.

Mating cycles: max. 10,000



Conductor cross section ²⁾		Nom.-Ø contact	Surface	Order No.	Type	Max. rated current ³⁾
mm ²	AWG	mm				A
0.5 – 1.5	20 – 16	2		18.9061	DSP2/0,5-1,5 AU	 2 – 10
				18.8061	DBP2/0,5-1,5 AU	



Assembly instructions MA202

www.staubli.com/electrical









Assembly tools, page 86

¹⁾ With 1 mm spring insertion

²⁾ If the number of contacts is > 2, when selecting the conductor cross-sections observe DIN VDE 0298-4, DIN EN 60204-1 and the derating diagrams, page 95

³⁾ Dependent on conductor cross section

For appropriate carrier size on pages 50, 53					Blind plug
G1	G2	G3	G4		
6+PE	15+PE	24+PE / 27 / 36+PE	70+2PE	18.5500	
6+PE	15+PE	24+PE / 27 / 36+PE	70+2PE	18.5500	
6+PE	15+PE	24+PE / 27 / 36+PE	70+2PE	18.5500	
6+PE	15+PE	24+PE / 27 / 36+PE	70+2PE	18.5500	
6+PE	15+PE	24+PE / 27 / 36+PE	70+2PE	18.5500	
6+PE	15+PE	24+PE / 27 / 36+PE	70+2PE	18.5500	
6+PE	15+PE	24+PE / 27 / 36+PE	70+2PE	18.5500	



Contact carrier with pressure contact sockets



Contact carrier with pressure contact pins, mixed with standard pins

For appropriate carrier size on pages 50, 53					Blind plug
G1	G2	G3	G4		
6+PE	15+PE	24+PE / 27 / 36+PE	70+2PE	18.5500	

Contacts for BUS applications

Standard version

Contacts for the transmission of BUS signals and are suitable for cable cross-sections of 0.14 mm² to 1.5 mm².

They are either silver plated (Ag) or gold plated (Au) and every socket is provided with the tried and tested MULTILAM.

These contacts can then be used in different types of contact carriers (up to 72 poles), including hybrid carriers (page 53).

Important:

Empty contact cavities must be fitted with blind plugs. If the cavities are only partly

occupied, care must be taken to distribute the contacts evenly in the carrier; this way, connectors remain longitudinally waterproof and carriers do not get deformed.

Mating cycles: max. 1,000,000



Conductor cross section ¹⁾		Nom.-Ø contact	Surface	Order No.	Type	Max. rated current ²⁾
mm ²	AWG	mm				A
0.14 – 0.5	26 – 20	1.5		18.9025 18.8025	SP1,5/0,14-0,5 AU BP1,5/0,14-0,5 AU	1 – 10
0.2 – 1	24 – 18	1		18.9003 18.8003	SP1/1 AU BP1/1 AU	2 – 5
0.5 – 1.5	20 – 16	1.5		18.9004 18.8004	SP1,5/0,5-1,5 BP1,5/0,5-1,5	10 – 16
				18.9005 18.8005	SP1,5/0,5-1,5 AU BP1,5/0,5-1,5 AU	

¹⁾ If the number of contacts is > 2, when selecting the conductor cross-sections observe DIN VDE 0298-4, DIN EN 60204-1 and the derating diagrams, page 95

²⁾ Dependent on conductor cross section





Assembly tools, page 86



Assembly instructions MA202

www.staubli.com/electrical

For appropriate carrier size on page 52					Blind plug
G1	G2	G3	G4		
6+PE	15+PE	24+PE / 27 / 36+PE	70+2PE	18.5500	
18+PE	–	–	–	18.5506	
6+PE	15+PE	24+PE / 27 / 36+PE	70+2PE	18.5500	

Contacts for Hybrid applications

Standard and short version

Contacts for the connection of data leads with different voltages or for carriers equipped with mixed contacts, allowing the combination of power and control contacts (e.g. servo motor). They cover a range of cable cross sections from 0.14 mm² to 4 mm².

They are either silver plated (Ag) or gold plated (Au) and every socket is provided with the tried and tested MULTILAM.

Important:

Empty contact cavities must be fitted with blind plugs. If the cavities are only partly

occupied, care must be taken to distribute the contacts evenly in the carrier; this way, connectors remain longitudinally waterproof and carriers do not get deformed.

Mating cycles: max. 1,000,000



Conductor cross section ¹⁾		Nom.-Ø contact	Surface	Order No.	Type	Max. rated current ²⁾
mm ²	AWG					
0.14 – 0.5	26 – 20	1.5		18.9024 18.8024	SP1,5/0,14-0,5 BP1,5/0,14-0,5	1 – 10
				18.9025 18.8025	SP1,5/0,14-0,5 AU BP1,5/0,14-0,5 AU	
0.2 – 1	24 – 18	1		18.9002 18.8002	SP1/1 BP1/1	2 – 5
				18.9003 18.8003	SP1/1 AU BP1/1 AU	
0.5 – 1.5	20 – 16	1.5		18.9004 18.8004	SP1,5/0,5-1,5 BP1,5/0,5-1,5	10 – 16
				18.9005 18.8005	SP1,5/0,5-1,5 AU BP1,5/0,5-1,5 AU	

Short version

2.5 – 4	14 – 12	3		18.9012 18.8012	SP3/2,5-4(K) BP3/2,5-4(K)	20 – 32
				18.9013 18.8013	SP3/2,5-4(K) AU BP3/2,5-4(K) AU	

¹⁾ If the number of contacts is > 2, when selecting the conductor cross-sections observe DIN VDE 0298-4, DIN EN 60204-1 and the derating diagrams, page 95

²⁾ Dependent on conductor cross section







Assembly tools, page 86



Assembly instructions MA202

www.staubli.com/electrical

For appropriate carrier size on page 53					Blind plug
G1	G2	G3	G4		
6+PE	15+PE	24+PE / 27 / 36+PE	70+2PE	18.5500 	
18+PE	–	–	–	18.5506 	
6+PE	15+PE	24+PE / 27 / 36+PE	70+2PE	18.5500 	
–	3+PE+4 / 4+PE / 6+PE	–	–	18.5501 	

Hybrid applications

Standard version

Contacts for the connection of data leads with different voltages or for carriers equipped with mixed contacts, allowing the combination of power and control contacts (e.g. servo motor).

They cover a range of cable cross sections from 6 mm² to 50 mm².

They are either silver plated (Ag) or gold plated (Au) and every socket is provided with the tried and tested MULTILAM.

These contacts can then be used in different types of contact carriers, including in particular hybrid carriers (page 53).

Important:

Empty contact cavities must be fitted with blind plugs. If the cavities are only partly occupied, care must be taken to distribute the contacts evenly in the carrier; this way, connectors remain longitudinally waterproof and carriers do not get deformed.

Mating cycles: max. 500,000





Conductor cross section ¹⁾		Nom.-Ø contact mm	Surface	Order No.	Type	Max. rated current ²⁾ A
mm ²	AWG					
6	10	5		18.9016 18.8016	SP5/6 BP5/6	 50
				18.9030 18.8030	SP5/6 AU BP5/6 AU	
10	8	5		18.9017 18.8017	SP5/10 BP5/10	 63
				18.9031 18.8031	SP5/10 AU BP5/10 AU	
25	4	11		18.9055 18.8055	SP11/25 BP11/25	 135
35 – 38	~ 2	11		18.9021 18.8021	SP11/35-38 BP11/35-38 ³⁾	 170
50	1/0	11		18.9056 18.8056	SP11/50 BP11/50 ³⁾	 200

¹⁾ If the number of contacts is > 2, when selecting the conductor cross-sections observe DIN VDE 0298-4, DIN EN 60204-1 and the derating diagrams, page 95

²⁾ Dependent on conductor cross section

³⁾ IP2X

For appropriate carrier size on page 53					Blind plug
G1	G2	G3	G4		
-	-	6+PE	-	18.5502 	
-	-	6+PE	-	18.5502 	
-	-	-	2+PE	-	
-	-	-	2+PE	-	
-	-	-	2+PE	-	

Contacts for Power applications

Standard and short version

Contacts for the transmission of currents between 10 A and 36 A for cable cross sections from 0.5 mm² to 4 mm².

They are mainly silver plated (Ag), or also gold plated (Au) for demanding applications and every socket is provided with the tried

and tested MULTILAM. These contacts can be used in different types of contact carriers (up to 37 poles).

Important:

Empty contact cavities must be fitted with blind plugs. If the cavities are only partly

occupied, care must be taken to distribute the contacts evenly in the carrier; this way, connectors remain longitudinally waterproof and carriers do not get deformed.

Mating cycles: max. 1,000,000



Conductor cross section ¹⁾		Nom.-Ø contact mm	Surface	Order No.	Type	Max. rated current ²⁾ A
mm ²	AWG					
0.5 – 1.5	20 – 16	2		18.9008 18.8008	SP2/0,5-1,5 BP2/0,5-1,5	10 – 16
				18.9009 18.8009	SP2/0,5-1,5 AU BP2/0,5-1,5 AU	
2.5	14	2		18.9010 18.8010	SP2/2,5 BP2/2,5	16 – 20
				18.9011 18.8011	SP2/2,5 AU BP2/2,5 AU	
2.5 – 4	14 – 12	3		18.9014 18.8014	SP3/2,5-4 BP3/2,5-4	20 – 36
				18.9015 18.8015	SP3/2,5-4 AU BP3/2,5-4 AU	

Short version

These contacts are ideal for applications with limited stroke distance (8 mm shorter in mated condition).

2.5 – 4	14 – 12	3		18.9012 18.8012	SP3/2,5-4(K) BP3/2,5-4(K)	20 – 32
				18.9013 18.8013	SP3/2,5-4(K) AU BP3/2,5-4(K) AU	

¹⁾ If the number of contacts is > 2, when selecting the conductor cross-sections observe DIN VDE 0298-4, DIN EN 60204-1 and the derating diagrams, page 95

²⁾ Dependent on conductor cross section







Assembly tools, page 86



Assembly instructions MA202

www.staubli.com/electrical

For appropriate carrier size on page 54					Blind plug
G1	G2	G3	G4		
6+PE	15+PE	–	–	18.5500 	
6+PE (TPE)	–	36+PE (CR/SIL)	–	18.5500 	
–	–	13+PE	–	18.5501 	
2+PE	3+PE+4 / 4+PE / 6+PE	–	–	18.5501 	

Contacts for High Current applications

Standard version

Contacts for the transmission of currents between 50 A and 135 A for cable cross sections from 6 mm² to 25 mm². They are silver plated (Ag), or also gold plated (Au) for demanding applications and every socket is provided with the tried and tested

MULTILAM.

These contacts can then be used in different types of contact carriers (up to 7 poles).

Important:

Empty contact cavities must be fitted with blind plugs. If the cavities are only partly

occupied, care must be taken to distribute the contacts evenly in the carrier; this way, connectors remain longitudinally waterproof and carriers do not get deformed.

Mating cycles: max. 500,000



Conductor cross section ¹⁾		Nom.-Ø contact mm	Surface	Order No.	Type	Max. rated current ²⁾ A
mm ²	AWG					
6	10	5		18.9016 18.8016	SP5/6 BP5/6	50
				18.9030 18.8030	SP5/6 AU BP5/6 AU	
6	10	6		18.9029 18.8029	SP6/6 BP6/6	50
				18.9032 18.8032	SP6/6 AU BP6/6 AU	
10	8	5		18.9017 18.8017	SP5/10 BP5/10	63
				18.9031 18.8031	SP5/10 AU BP5/10 AU	
10	8	6		18.9018 18.8018	SP6/10 BP6/10	80
				18.9033 18.8033	SP6/10 AU BP6/10 AU	
16	6	6		18.9019 18.8019	SP6/16 BP6/16	90
				18.9034 18.8034	SP6/16 AU BP6/16 AU	
25	4	6		18.9020 18.8020	SP6/25 BP6/25	135
				18.9035 18.8035	SP6/25 AU BP6/25 AU	









Assembly instructions MA202

www.staubli.com/electrical

¹⁾ If the number of contacts is > 2, when selecting the conductor cross-sections observe DIN VDE 0298-4, DIN EN 60204-1 and the derating diagrams, page 95

²⁾ Dependent on conductor cross section

For appropriate carrier size on page 55					Blind plug
G1	G2	G3	G4		
-	-	6+PE	-	18.5502 	
-	-	2+PE / 4+PE	-	18.5503 	
-	-	6+PE	-	18.5502 	
-	-	2+PE / 4+PE	-	18.5503 	
-	-	2+PE / 4+PE	-	18.5503 	
-	-	2+PE	-	18.5503 	

High Current applications

Standard version

Contacts for the transmission of currents between 135 A and 200 A for cable cross sections from 25 mm² to 50 mm².

They are either silver plated (Ag) and every socket is provided with the tried and tested MULTILAM.

These contacts can then be used in different types of contact carriers (up to 3 poles).

Important:

Empty contact cavities must be fitted with blind plugs. If the cavities are only partly occupied, care must be taken to distribute

the contacts evenly in the carrier; this way, connectors remain longitudinally waterproof and carriers do not get deformed.

Mating cycles: max. 500,000



Conductor cross section ¹⁾		Nom.-Ø contact	Surface	Order No.	Type	Max. rated current ²⁾
mm ²	AWG	mm				A
25	4	8		18.9050 18.8050	SP8/25 BP8/25	135
25	4	11		18.9055 18.8055	SP11/25 BP11/25	135
35	2	8		18.9051 18.8051	SP8/35 BP8/35	150
35 – 38	~ 2	11		18.9021 18.8021	SP11/35-38 BP11/35-38 ³⁾	170
50	1/0	11		18.9056 18.8056	SP11/50 BP11/50 ³⁾	200

¹⁾ If the number of contacts is > 2, when selecting the conductor cross-sections observe DIN VDE 0298-4, DIN EN 60204-1 and the derating diagrams, page 95



²⁾ Dependent on conductor cross section

³⁾ IP2X



Assembly instructions MA202

www.staubli.com/electrical

For appropriate carrier size on page 55					Blind plug
G1	G2	G3	G4		
-	-	2+PE	-	18.5505 	
-	-	-	2+PE	-	
-	-	2+PE	-	18.5505 	
-	-	-	2+PE	-	
-	-	-	2+PE	-	

Contacts for PEEK applications

Standard version

Special contacts for the transmission of currents up to 200 A for cable cross sections from 0.15 mm² to 70 mm².

They are gold plated (Au) and every socket is provided with the tried and tested MULTILAM.

These contacts can be used in different types of machined contact carriers (up to 48 poles), plus custom carriers, if necessary.

Important:

If the cavities are only partly occupied, care must be taken to distribute the contacts evenly in the carrier.

Mating cycles: max. 10,000

Note:

Ø 6 mm and Ø 10 mm contacts are on request.

Availability:

Not in stock. Price and lead-time upon request.



Conductor cross section ¹⁾		Nom.-Ø contact mm	Surface	Order No.	Type	Max. rated current ²⁾ A
mm ²	AWG					
0.15 – 0.75	26 – 18	1		19.9110 19.9108	CT-NET/S ³⁾ CT-NET/B ³⁾	5
0.5 – 1.5	20 – 16	1.6		19.6742 19.6741	SP-C1,6/0,5-1,5 AU BP-C1,6/0,5-1,5 AU	16
2.5 – 4	14 – 12	3		19.6744 19.6743	SP-C3/2,5-4 AU BP-C3/2,5-4 AU	36
4 – 6	12 – 10			19.6759 19.6745	SP-C3/4-6 AU BP-C3/4-6 AU	50
10	8	6		19.6748 19.6747	SP-C6/10 AU BP-C6/10 AU	80
16	6			19.6750 19.6749	SP-C6/16 AU BP-C6/16 AU	110
25	4			19.6752 19.6751	SP-C6/25 AU BP-C6/25 AU	135
35	2	10		19.6754 19.6753	SP-R10/35 AU BP-R10/35 AU	150
50	1/0			19.6756 19.6755	SP-R10/50 AU BP-R10/50 AU	180
70	2/0			19.6758 19.6757	SP-R10/70 AU BP-R10/70 AU	200

¹⁾ If the number of contacts is > 2, when selecting the conductor cross-sections observe DIN VDE 0298-4, DIN EN 60204-1 and the derating diagrams, page 95



²⁾ Dependent on conductor cross section

³⁾ Set including 8 contacts







Assembly instructions MA303

www.staubli.com/electrical

For appropriate carrier size on page 61				
	G1	G2	G3	G4
	-	-	4	-
	-	19+PE	47+PE	-
	-	3+PE	9+PE	-
	-	3+PE	13+PE	-
	-	-	3+PE	-
	-	-	3+PE	-
	-	-	3+PE	-
	-	1 	-	-
	-	1 	-	-
	-	1 	-	-

CONTACT CARRIERS

Overview of contact carriers

	Carrier size	Number of poles	Rated voltage	Page
			V	
NBR				
Signal applications				
	G1 – G4	6+PE – 70+2PE	25 – 250	50
BUS applications				
	G1 – G4	6+PE – 70+2PE	25 – 250	52
Hybrid applications				
	G1 – G2, G4	2+PE+6 2+PE+9 3+PE+4	25 – 830	53
Power applications				
	G1 – G3	2+PE – 36+PE	250 – 630	54
High Current applications				
	G3 – G4	2+PE – 6+PE	400 – 630	55

Note:

All earth contacts (PE) are mating first and breaking last:

- Up to a nominal Ø of 3 mm, the pin mates first and breaks last.
- As of a nominal Ø of 5 mm, the socket mates first and breaks last.

	Carrier size	Number of poles	Rated voltage	Page
			V	

Chloroprene (CR)

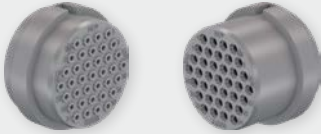
	G3	36+PE	250	56
--	----	-------	-----	----

Silicone (SIL)

	G2 – G3	3+PE+4 6+PE 15+PE 36+PE	250 – 830	57
--	---------	----------------------------------	-----------	----

PEEK (PK) – on request –

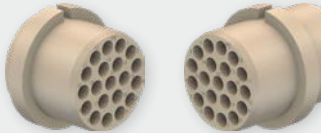
	G2 – G3	1 – 47+PE	24 – 600	59
---	---------	-----------	----------	----

TPE

	G1	6+PE	250	52
--	----	------	-----	----

Contact carriers for Signal applications

Standard, without contacts

The pin and socket carriers are made of synthetic rubber. After the leads have been crimped onto the pins and sockets resp., they can be mounted and dismounted with the suitable tooling accordingly (See

page 86). The pins and sockets are seated elastically in their carrier.

Operating temperature: +5 °C...+100 °C.

Note:

- The nominal voltage can be increased by selectively populating the carrier with less contacts. Ask us for special pole diagrams!
- Inserts populated with contacts see page 62.



Type code example:

E1-6PE/S

E1-6PE/S	Empty Contact carrier
E1-6PE/S	Housing size
E1-6 PE /S	Number of contacts
E1-6PE/ S	S: Pin; B: Socket



Assembly tools, page 86

Carrier size	Number of poles	Order No.	Type	Rated voltage for plastic housings	To fit housing size
				V	
G1	6+PE	18.4201	E1-6PE/S	250	MGK1... MGS1...-IS MGS1...-S
		18.4301	E1-6PE/B		
	18+PE	18.4202	E1-18PE/S	150 ¹⁾	
		18.4302	E1-18PE/B		
G2	15+PE	18.4401	E2-15PE/S	250	MGK2... MGS2...-IS MGA2...
		18.4501	E2-15PE/B		
G3	24+PE	18.4604	E3-24PE/S	250	MGK3... MGS3...-IS MGA3...
		18.4704	E3-24PE/B		
	27	18.4605	E3-27/S	25 	
		18.4705	E3-27/B		
	36+PE	18.4606	E3-36PE/S	250	
		18.4706	E3-36PE/B		
G4	70+2PE	18.4800	E4-70/2PE/S	250	MGK4...
		18.4900	E4-70/2PE/B		

¹⁾ Special contact arrangements are required for applications using 250 V; please request pole diagram.

Contact carriers for BUS applications

Standard, without contacts

The pin and socket carriers are made of synthetic rubber. After the leads have been crimped onto the pins and sockets resp., they can be mounted and dismantled with the suitable tooling accordingly (See

page 86). The pins and sockets are seated elastically in their carrier.

Operating temperature: +5 °C...+100 °C²⁾.

Note:

The nominal voltage can be increased by selectively populating the carrier with less contacts. Ask us for special pole diagrams!



Carrier size	Number of poles	Order No.	Type	Rated voltage	To fit housing size
				V	
G1	2+PE+9	18.4203	E1-2PE+9/S	250 25 ¹⁾	MGK1... MGS1...-IS MGS1...-S
		18.4303	E1-2PE+9/B		
	6+PE (for 0.5-1.5 mm ²)	18.4201	E1-6PE/S	250	
		18.4301	E1-6PE/B		
	6+PE (for 2.5 mm ²)	18.4204 ²⁾	E1-6PE/S		
		18.4304 ²⁾	E1-6PE/B		
18+PE	18.4202	E1-18PE/S	250		
	18.4302	E1-18PE/B			
G2	15+PE	18.4401	E2-15PE/S	250	MGK2... MGS2...-IS MGA2...
		18.4501	E2-15PE/B		
G3	24+PE	18.4604	E3-24PE/S	250	MGK3... MGS3...-IS MGA3...
		18.4704	E3-24PE/B		
	27	18.4605	E3-27/S	25	
		18.4705	E3-27/B		
	36+PE	18.4606	E3-36PE/S	250	
		18.4706	E3-36PE/B		
G4	70+2PE	18.4800	E4-70/2PE/S	250	MGK4...
		18.4900	E4-70/2PE/B		

¹⁾ For pilot contacts

²⁾ Special TPE carrier with operating temperature: -20 °C ... +90 °C



Assembly tools, page 86

Contact carriers for Hybrid applications

Standard, without contacts

The pin and socket carriers are made of synthetic rubber. After the leads have been crimped onto the pins and sockets resp., they can be mounted and dismantled with the suitable tooling accordingly (See

page 86). The pins and sockets are seated elastically in their carrier.

Operating temperature: +5 °C...+100 °C.

Note:

- The nominal voltage can be increased by selectively populating the carrier with less contacts. Ask us for special pole diagrams!
- Inserts populated with contacts see page 64.



Carrier size	Number of poles	Order No.	Type	Rated voltage	To fit housing size
				V	
G1	2+PE+9	18.4203	E1-2PE+9/S	250 25 ¹⁾	MGK1... MGS1...-IS MGS1...-S
		18.4303	E1-2PE+9/B		
G2	3+PE+4	18.4403	E2-3PE+4/S	830 250 ¹⁾	MGK2... MGS2...-IS MGA2...
		18.4503	E2-3PE+4/B		
G4	2+PE+6	18.4801	E4-2PE+6/S	630 25 ¹⁾	MGK4...
		18.4901	E4-2PE+6/B		

¹⁾ For pilot contacts



Assembly tools, page 86

Contact carriers for Power applications

Standard, without contacts

The pin and socket carriers are made of synthetic rubber. After the leads have been crimped onto the pins and sockets resp., they can be mounted and dismantled with the suitable tooling accordingly (See

page 86). The pins and sockets are seated elastically in their carrier.

Operating temperature: +5 °C...+100 °C.

Note:

- The nominal voltage can be increased by selectively populating the carrier with less contacts. Ask us for special pole diagrams!
- Inserts populated with contacts see page 66.



Carrier size	Number of poles	Order No.	Type	Rated voltage for plastic housings	To fit housing size
				V	
G1	2+PE	18.4200	E1-2PE/S	250	MGK1... MGS1...-IS MGS1...-S
		18.4300	E1-2PE/B		
	6+PE	18.4201	E1-6PE/S		
		18.4301	E1-6PE/B		
G2	6+PE	18.4400	E2-6PE/S	400	MGK2... MGS2...-IS MGA2...
		18.4500	E2-6PE/B		
	15+PE	18.4401	E2-15PE/S	250	
		18.4501	E2-15PE/B		
G3	2+PE	18.4650	E3-2PE/S8	630	MGK3... MGS3...-IS MGA3...
		18.4750	E3-2PE/B8		
		18.4600	E3-2PE/S		
		18.4700	E3-2PE/B		
	4+PE	18.4601	E3-4PE/S	400	
		18.4701	E3-4PE/B		
	6+PE	18.4602	E3-6PE/S	400	
		18.4702	E3-6PE/B		
	13+PE	18.4603	E3-13PE/S	400	
		18.4703	E3-13PE/B		
	36+PE	18.4606	E3-36PE/S	250	
		18.4706	E3-36PE/B		



Assembly tools, page 86

Contact carriers for High Current applications

Standard, without contacts

The pin and socket carriers are made of synthetic rubber. After the leads have been crimped onto the pins and sockets resp., they can be mounted and dismantled with the suitable tooling accordingly (See

page 86). The pins and sockets are seated elastically in their carrier.

Operating temperature: +5 °C...+100 °C.

Note:

- The nominal voltage can be increased by selectively populating the carrier with less contacts. Ask us for special pole diagrams!
- Inserts populated with contacts see page 68.



Carrier size	Number of poles	Order No.	Type	Rated voltage for plastic housings	To fit housing size
				V	
G3	2+PE	18.4650	E3-2PE/S8	630	MGK3... MGS3...-IS MGA3...
		18.4750	E3-2PE/B8		
	2+PE	18.4600	E3-2PE/S	400	
		18.4700	E3-2PE/B		
	4+PE	18.4601	E3-4PE/S	400	
		18.4701	E3-4PE/B		
6+PE	18.4602	E3-6PE/S	400		
	18.4702	E3-6PE/B			
G4	2+PE	18.4802	E4-2PE/S	630	MGK4...
		18.4902	E4-2PE/B		



Assembly tools, page 86

Special contact carrier in Chloroprene

These grey contact carriers are suitable for oil-sensitive applications.

The swelling behavior with the following oils have been tested and passed:

- Motorex COOLANT-F
- AVIA Fluid HLPD-46
- FRAGOL Ucotherm W-EGA

For all other oil types, tests would need to be carried out.

Note:

- The nominal voltage can be increased by selectively populating the carrier with less contacts. Ask us for special pole diagrams!
- Inserts populated with contacts see page 70.
- Single contacts see page 28, 40.



Carrier size	Number of poles	Order No.	Type	Rated voltage	Operating temperature	To fit housing size
				V	°C	
G3	36+PE	18.4608	E3-36PE/S2,5-CR	250	-10...+100 °C	MGK3...
		18.4708	E3-36PE/B2,5-CR			MGA3...

Special contact carrier in Silicone

These red contact carriers, in combination with gold plated contacts, are suitable for high-temperature applications (up to 150°C).

Note:

- The nominal voltage can be increased by selectively populating the carrier with less contacts. Ask us for special pole diagrams!

- At temperatures above 90°C, we recommend the use of metallic housings.
- Inserts populated with contacts see page 71.
- Single contacts see page 40.



Carrier size	Number of poles	Order No.	Type	Rated voltage	Operating temperature	To fit housing size
				V	°C	
G2	3+PE+4	18.4612	E2-3+PE+4/S SIL	830	-10...+150 °C	MGK2... MGA2...
		18.4712	E2-3+PE+4/B SIL	250		
	6+PE	18.4613	E2-6PE/S SIL	400		
		18.4713	E2-6PE/B SIL	250		
	15+PE	18.4614	E2-15PE/S SIL	250		
		18.4714	E2-15PE/B SIL	250		
G3	6+PE	18.4609	E3-6PE/S SIL	400	-10...+150 °C	MGK3... MGA3...
		18.4709	E3-6PE/B SIL	250		
	36+PE	18.4607	E3-36PE/S2,5-SIL	250		
		18.4707	E3-36PE/B2,5-SIL	250		

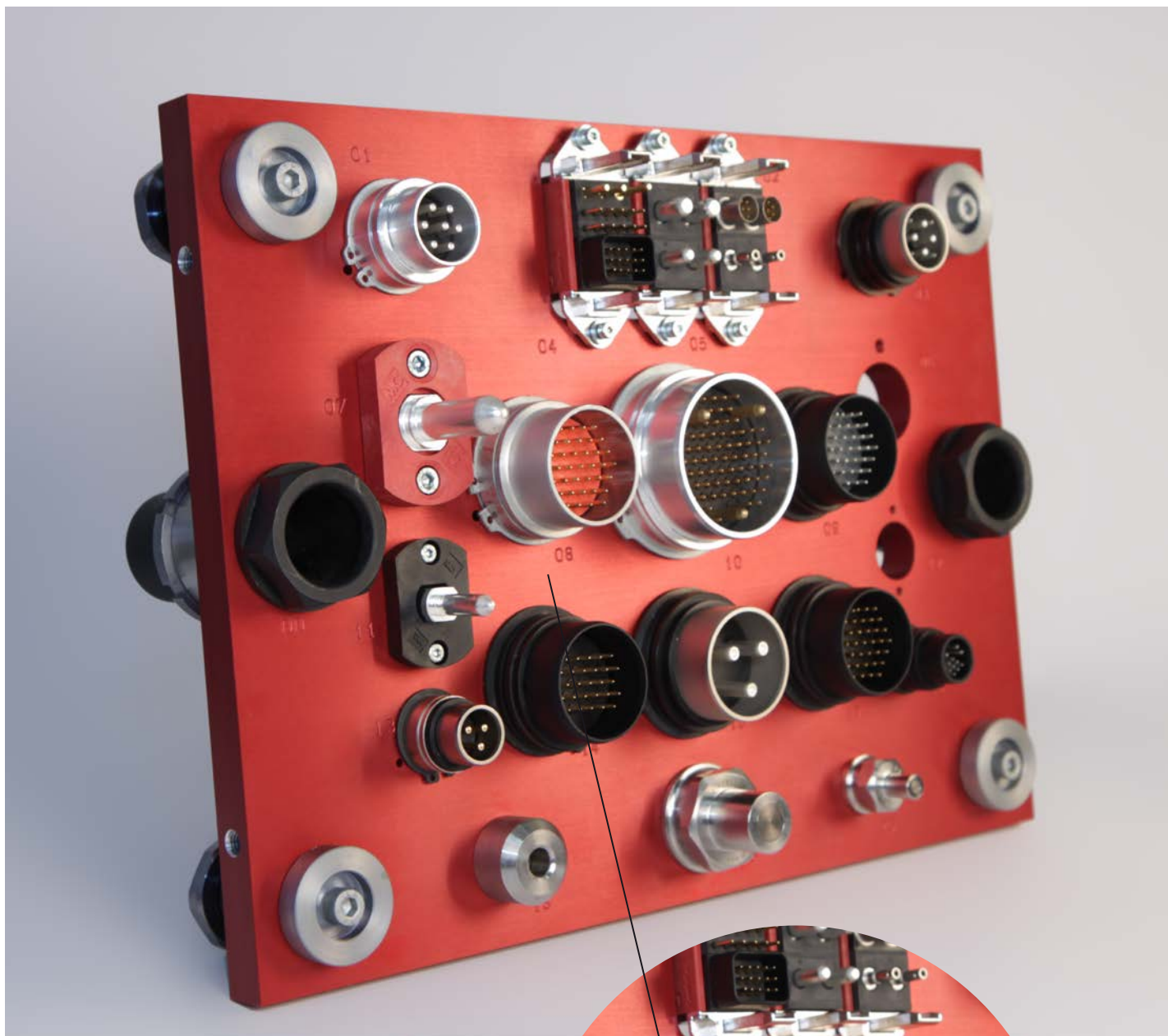

Special contact carrier in PEEK

Standard, without contacts

These beige pin and socket carriers are made of hard PEEK material and are suitable for very demanding areas of application, such as in nuclear technology. To match, there are 10 types of gold plated special contacts (see page 46). After the leads have been crimped onto the contacts, they can normally be fitted by hand. If nec-

essary, they can be removed using a suitable extraction tool (see page 86).

Operating temperature: -10 °C...+150 °C.

Note:

- The nominal voltage can be increased by selectively populating the carrier with less









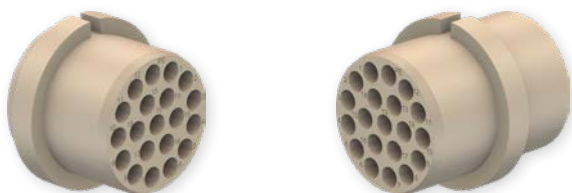

contacts. Ask us for special pole diagrams!

- Inserts populated with contacts see page 72.
- Single contacts see page 46.
-

Availability:

Not in stock. Price and lead-time on request.



Carrier size	Number of poles	Order No.	Type	Rated voltage for plastic housings	To fit housing size
				V	
G2	1 	19.6627	E2-1-PK/S	 600	MGK2... MGS2...-IS MGA2...
		19.6626	E2-1-PK/B ²⁾		
	3+PE	19.6633	E2-3PE-PK/S	 600	
		19.6632	E2-3PE-PK/B		
	19+PE	19.6635	E2-19PE-PK/S	 150	
		19.6634	E2-19PE-PK/B		
G3	3+PE	19.6637	E3-3PE-PK/S	 600	MGK3... MGS3...-IS MGA3...
		19.6636	E3-3PE-PK/B		
	9+PE	19.6645	E3-9PE-PK/S	 600	
		19.6644	E3-9PE-PK/B		
	13+PE ¹⁾	19.6649	E3-13PE-PK/S	 600	
		19.6648	E3-13PE-PK/B		
	47+PE	19.6647	E3-47PE-PK/S	 150	
		19.6646	E3-47PE-PK/B		
	4xNET 	19.9109	E3-4NET-PK/S	 24	
		19.9106	E3-4NET-PK/B		

¹⁾ Mating compatibility with the standard (NBR) version





²⁾ No touch protection



Assembly tools, page 86

CONTACT INSERT SETS

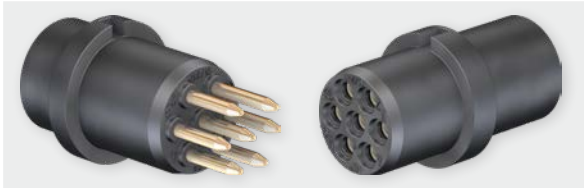
Overview

	Carrier size	Number of poles	Rated voltage	Page
			V	
NBR				
Signal applications				
	G1 – G4	6+PE – 70+2PE	25 – 250	62
Hybrid applications				
	G1, G2, G4	2+PE+6 – 3+PE+4	250 – 830	64
Power applications				
	G1 – G3	2+PE – 15+PE	250 – 400	66
High Current applications				
	G3 – G4	2+PE – 6+PE	25 – 630	68

Note:

All earth contacts (PE) are mating first and breaking last:

- Up to a nominal Ø of 3 mm, the pin mates first and breaks last.
- As of a nominal Ø of 5 mm, the socket mates first and breaks last.

	Carrier size	Number of poles	Rated voltage	Page
			V	

Chloroprene (CR)

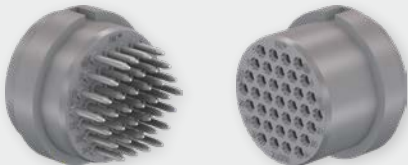
	G3	36+PE	250	70
--	----	-------	-----	----

Silicone (SIL)

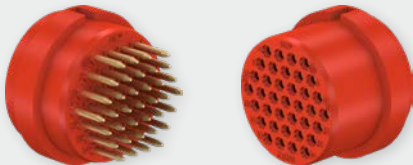
	G2 – G3	3+PE+4 6+PE 15+PE 36+PE	250 – 830	71
--	---------	----------------------------------	-----------	----

PEEK (PK) – on request –

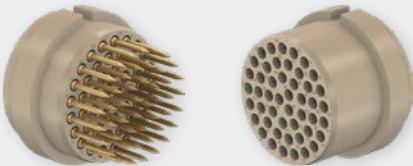
	G2 – G3	1 – 47+PE	24 – 600	72
--	---------	-----------	----------	----

Contact insert sets for Signal applications

These sets are consisting of a contact carrier and the corresponding number of pins or sockets.

This makes it easier for you to order contact carriers which are to be fully loaded (after crimping).

Note:





















































- Empty contact carrier see page 48.
- Single contacts pins/sockets see page 28.



Type code example:

ME1-18+PE-SP1/1 AU

ME1-18+PE-SP1/1 AU	Contact insert-set
ME1-18+PE-SP1/1 AU	Housing size
ME1- 18+PE -SP1/1 AU	Number of contacts
ME1-18+PE- SP 1/1 AU	SP: Pin; BP: Socket
ME1-18+PE-SP 1 /1 AU	Nom.-Ø pin (mm)
ME1-18+PE-SP1/ 1 AU	max. conductor cross section (mm ²)
ME1-18+PE-SP1/1 AU	Surface

Carrier size	Conductor cross section		Number of poles	Nom.-Ø Contact	Surface	Order No.	Type	Max. rated current	Rated voltage
	mm ²	AWG							
G1	0.2 – 1	24 – 18	18+PE	1		18.1206	ME1-18+PE-SP1/1	 5	 150 ¹⁾
						18.1207	ME1-18+PE-BP1/1		
						18.1306	ME1-18+PE-SP1/1 AU		
						18.1307	ME1-18+PE-BP1/1 AU		
	0.5 – 1.5	20 – 16	6+PE	2		18.1202	ME1-6+PE-SP2/0,5-1,5	 16	 250
						18.1203	ME1-6+PE-BP2/0,5-1,5		
						18.1302	ME1-6+PE-SP2/0,5-1,5 AU		
						18.1303	ME1-6+PE-BP2/0,5-1,5 AU		
				1.5		18.1204	ME1-6+PE-SP1,5/0,5-1,5		
						18.1205	ME1-6+PE-BP1,5/0,5-1,5		
						18.1304	ME1-6+PE-SP1,5/0,5-1,5 AU		
						18.1305	ME1-6+PE-BP1,5/0,5-1,5 AU		
	2.5	14	6+PE	2		18.1214	ME1-6+PE-SP2/2,5	 16	 250
						18.1314	ME1-6+PE-BP2/2,5		
						18.1215	ME1-6+PE-SP2/2,5 AU		
						18.1315	ME1-6+PE-BP2/2,5 AU		
G2	0.5 – 1.5	20 – 16	15+PE	2		18.1404	ME2-15+PE-SP2/0,5-1,5	 16	 250
						18.1405	ME2-15+PE-BP2/0,5-1,5		
						18.1504	ME2-15+PE-SP2/0,5-1,5 AU		
						18.1505	ME2-15+PE-BP2/0,5-1,5 AU		
				1.5		18.1406	ME2-15+PE-SP1,5/0,5-1,5		
						18.1407	ME2-15+PE-BP1,5/0,5-1,5		
						18.1506	ME2-15+PE-SP1,5/0,5-1,5 AU		
						18.1507	ME2-15+PE-BP1,5/0,5-1,5 AU		
G3	0.5 – 1.5	20 – 16	24+PE	1.5		18.1616	ME3-24+PE-SP1,5/0,5-1,5 ²⁾	 16	 250
						18.1617	ME3-24+PE-BP1,5/0,5-1,5 ²⁾		
						18.1702	ME3-24+PE-SP1,5/0,5-1,5 AU ²⁾		
						18.1703	ME3-24+PE-BP1,5/0,5-1,5 AU ²⁾		
			27	1.5		18.1618	ME3-27-SP1,5/0,5-1,5		
						18.1619	ME3-27-BP1,5/0,5-1,5		
						18.1704	ME3-27-SP1,5/0,5-1,5 AU		
						18.1705	ME3-27-BP1,5/0,5-1,5 AU		
			36+PE	1.5		18.1622	ME3-36+PE-SP1,5/0,5-1,5		
						18.1623	ME3-36+PE-BP1,5/0,5-1,5		
						18.1708	ME3-36+PE-SP1,5/0,5-1,5 AU		
						18.1709	ME3-36+PE-BP1,5/0,5-1,5 AU		
G4	0.5 – 1.5	20 – 16	70+2PE	1.5		18.1800	ME4-70+2PE-SP1,5/0,5-1,5	 16	 250
						18.1801	ME4-70+2PE-BP1,5/0,5-1,5		
						18.1900	ME4-70+2PE-SP1,5/0,5-1,5 AU		
						18.1901	ME4-70+2PE-BP1,5/0,5-1,5 AU		

¹⁾ Special contact arrangements are required for applications using 250 V; please request pole diagram.

²⁾ Also available with: SP1,5/0,14-0,5 / BP1,5/0,14-0,5

Contact insert sets for Hybrid applications



Contact inserts equipped with mixed contacts for power supply and signal transmission to servo motors.

Note:

- Empty contact carrier see page 53.
- Single contacts pins/sockets see page 36.



Carrier size	Number of poles (Power & Signal)	Power						Signal			
		Conductor cross section		Number of poles	Nom.-Ø contact	Max. rated current	Rated voltage	Conductor cross section		Number of poles	
		mm ²	AWG					mm ²	AWG		
G1	2+PE+9	0.5 – 1.5	20 – 16	2+PE	1.5	16	250	0.2 – 1		9	
G2	3+PE+4	2.5 – 4	14 – 12	3+PE	3	32	830	0.5 – 1.5	20 – 16	4	
G4	2+PE+6	25/50	4 – 1/0	2+PE	11	200	630	0.5 – 1.5	20 – 16	6	
		35-38	~ 2			170					

	Nom.-Ø contact	Max. rated current	Rated voltage	Surface	Order No.	Type
	mm	A	V			
	1	5	25		18.1212	ME1-2+PE-SP1,5/0,5-1,5+9SP1/1K
					18.1312	ME1-2+PE-BP1,5/0,5-1,5+9BP1/1K
	1.5	16	250		18.1410	ME2-3+PE-SP3/2,5-4(K)+4SP1,5/0,5-1,5
					18.1411	ME2-3+PE-BP3/2,5-4(K)+4BP1,5/0,5-1,5
	1.5	5	25		18.1816	ME4-2+PE-SP11/25+50 ¹⁾
					18.1817	ME4-2+PE-BP11/25+50 ¹⁾
					18.1812	ME4-2+PE-SP11/35-38 ¹⁾
					18.1813	ME4-2+PE-BP11/35-38 ¹⁾

¹⁾ Can be fitted with up to 6 pilot contacts (please order separately)

Contact insert sets for Power applications

The contact insert sets are consisting of a contact carrier and the corresponding number of pins or sockets.

This makes it easier for you to order contact carriers which are to be fully loaded (after crimping).

Note:















- Empty contact carrier see page 54.
- Single contacts pins/sockets see page 40.



Type code example:

ME1-6+PE-SP2/0,5-1,5 AU

ME1-6+PE-SP2/0,5-1,5 AU	Contact insert-set
ME1-6+PE-SP2/0,5-1,5 AU	Housing size
ME1- 6+PE -SP2/0,5-1,5 AU	Number of contacts
ME1-6+PE- SP 2/0,5-1,5 AU	SP : Pin; BP : Socket
ME1-6+PE-SP2/0,5-1,5 AU	Nom.-Ø pin (mm)
ME1-6+PE-SP2/ 0,5-1,5 AU	max. conductor cross section (mm ²)
ME1-6+PE-SP2/0,5-1,5 AU	Surface

Carrier size	Conductor cross section		Number of poles	Nom.-Ø Contact	Surface	Order No.	Type	Max. rated current	Rated voltage
	mm ²	AWG							
G1	0.5 – 1.5	20 – 16	6+PE	2		18.1202	ME1-6+PE-SP2/0,5-1,5	 16	 250
					18.1203	ME1-6+PE-BP2/0,5-1,5			
		18.1302	ME1-6+PE-SP2/0,5-1,5 AU						
	18.1303	ME1-6+PE-BP2/0,5-1,5 AU							
	2.5 – 4	14 – 12	2+PE	3		18.1200	ME1-2+PE-SP3/2,5-4(K)	 36	
					18.1201	ME1-2+PE-BP3/2,5-4(K)			
					18.1300	ME1-2+PE-SP3/2,5-4(K) AU			
18.1301					ME1-2+PE-BP3/2,5-4(K) AU				
G2	0.5 – 1.5	20 – 16	15+PE	2		18.1404	ME2-15+PE-SP2/0,5-1,5	 16	 400
					18.1405	ME2-15+PE-BP2/0,5-1,5			
						18.1504	ME2-15+PE-SP2/0,5-1,5 AU		
					18.1505	ME2-15+PE-BP2/0,5-1,5 AU			
	2.5 – 4	14 – 12	4+PE	3		18.1400	ME2-4+PE-SP3/2,5-4(K)	 36	
					18.1401	ME2-4+PE-BP3/2,5-4(K)			
						18.1500	ME2-4+PE-SP3/2,5-4(K) AU		
			18.1501		ME2-4+PE-BP3/2,5-4(K) AU				
			6+PE			18.1402	ME2-6+PE-SP3/2,5-4(K)		
					18.1403	ME2-6+PE-BP3/2,5-4(K)			
	18.1502	ME2-6+PE-SP3/2,5-4(K) AU							
18.1503	ME2-6+PE-BP3/2,5-4(K) AU								
G3	2.5 – 4	14 – 12	13+PE	3		18.1614	ME3-13+PE-SP3/2,5-4	 27	 400
					18.1615	ME3-13+PE-BP3/2,5-4			
						18.1700	ME3-13+PE-SP3/2,5-4 AU		
					18.1701	ME3-13+PE-BP3/2,5-4 AU			

Contact insert sets for High Current applications

The contact insert sets are consisting of a contact carrier and the corresponding number of pins or sockets.

This makes it easier for you to order contact carriers which are to be fully loaded (after crimping).

Note:

- Empty contact carrier see page 55.
- Single contacts pins/sockets see page 42.



Type code example:

ME3-6+PE-SP5/6

ME3-6+PE-SP5/6	Contact insert-set
ME3-6+PE-SP5/6	Housing size
ME3- 6+PE -SP5/6	Number of contacts
ME3-6+PE- SP 5/6	SP : Pin; BP : Socket
ME3-6+PE-SP 5 /6	Nom.-Ø pin (mm)
ME3-6+PE-SP5/ 6	max. conductor cross section (mm ²)

Carrier size	Conductor cross section		Number of poles	Nom.-Ø Contact	Surface	Order No.	Type	Max. rated current	Rated voltage		
	mm ²	AWG								mm	A
G3	6	10	6+PE	5		18.1612	ME3-6+PE-SP5/6	50	400		
						18.1613	ME3-6+PE-BP5/6				
	10	8	2+PE	6		18.1604	ME3-2+PE-SP6/10	80	630		
						18.1605	ME3-2+PE-BP6/10				
			4+PE	6		18.1608	ME3-4+PE-SP6/10	63	400		
						18.1609	ME3-4+PE-BP6/10				
						6+PE	5			18.1610	ME3-6+PE-SP5/10
										18.1611	ME3-6+PE-BP5/10
	16	6	2+PE	6		18.1602	ME3-2+PE-SP6/16	110	630		
						18.1603	ME3-2+PE-BP6/16				
			4+PE	6		18.1606	ME3-4+PE-SP6/16	90	400		
						18.1607	ME3-4+PE-BP6/16				
	25	4	2+PE	6		18.1600	ME3-2+PE-SP6/25	135	630		
				8		18.1601	ME3-2+PE-BP6/25				
				8		18.1750	ME3-2+PE-SP8/25				
	35	2	2+PE	8		18.1751	ME3-2+PE-BP8/25	150	630		
						18.1752	ME3-2+PE-SP8/35				
						18.1753	ME3-2+PE-BP8/35				
G4	25/50	4 - 1/0	2+PE	11		18.1816	ME4-2+PE-SP11/25+50 ¹⁾	200	630		
						18.1817	ME4-2+PE-BP11/25+50 ¹⁾				
	35 - 38	2				18.1812	ME4-2+PE-SP11/35-38 ¹⁾	170		25 ²⁾	
						18.1813	ME4-2+PE-BP11/35-38 ¹⁾				

¹⁾ Can be fitted with up to 6 pilot contacts (please order separately)

²⁾ For pilot contacts

Special contact insert sets for Chloroprene applications

The contact inserts consist of the grey contact carriers and the corresponding number of pins or sockets.

This makes it easier for you to order contact carriers which are to be fully loaded (after crimping). These grey contact carriers are suitable for oil-sensitive applications.

The swelling behavior with the following oils have been tested and passed:

- Motorex COOLANT-F
- AVIA Fluid HLPD-46
- FRAGOL Ucotherm W-EGA

For all other oil types, tests would need to be carried out.

Note:

- Empty contact carrier see page 56.
- Single contacts Pins/Sockets see pages 28, 40.

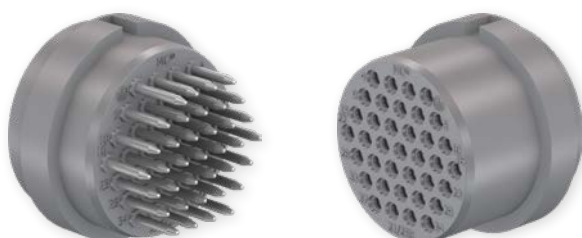

Carrier size	Conductor cross section		Number of poles	Nom.-Ø Contact	Surface	Order No.	Type	Max. rated current	Rated voltage
	mm ²	AWG							
G3	2.5	14	36+PE	2		18.1624	ME3-36+PE-SP2/2,5-CR		
						18.1625	ME3-36+PE-BP2/2,5-CR		

Special contact insert sets for Silicone applications

The contact inserts consist of the red contact carriers and the appropriate number of pins or sockets.

They are suitable for high-temperature applications (up to 150 °C).

For applications above 90 °C we recommend the use of gold plated contacts and tinned cable strands and the use of metallic housings.

This makes it easier for you to order contact carriers which are to be fully loaded (after crimping).

Note:

- Empty contact carrier see page 57.
- Single contacts see page 40.

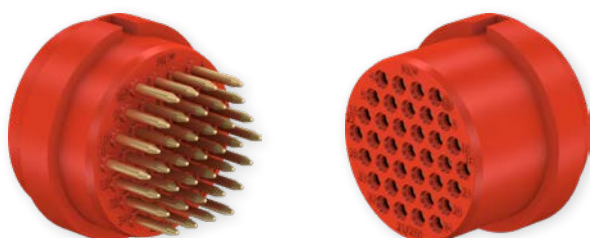

Carrier size	Conductor cross section		Number of poles	Nom.-Ø Contact	Surface	Order No.	Type	Max. rated current	Rated voltage
	mm ²	AWG							
G2	0.5 – 1.5	20 – 16	15+PE	2		18.1512	ME2-15PE/S SIL		
						18.1513	ME2-15PE/B SIL		
	2.5 – 4	14 – 12	3+PE+4	3		18.1508	ME2-3+PE+4/S SIL		
						18.1509	ME2-3+PE+4/B SIL		
	0.5 – 1.5	20 – 16	6+PE	3		18.1510	ME2-6PE/S SIL		
						18.1511	ME2-6PE/B SIL		
G3	2.5	14	36+PE	2		18.1706	ME3-36+PE-SP2/2,5-SIL AU		
						18.1707	ME3-36+PE-BP2/2,5-SIL AU		
	10	8	6+PE	5		18.1710	ME3-6PE/S SIL		
						18.1711	ME3-6PE/B SIL		

Special contact insert sets for PEEK applications

The contact insert sets are consisting of a contact carrier and the corresponding number of pins or sockets.

This makes it easier for you to order contact carriers which are to be fully loaded (after crimping).

Note:

- Empty contact carrier see page 59.
- Single contacts pins/sockets see page 46.

Availability:



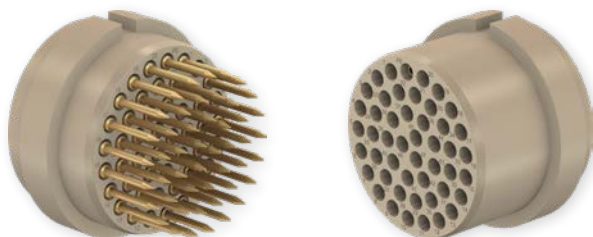



Not in stock. Price and lead-time on request.



Type code example:

ME2-19+PE-SP-C1,6/0,5-1,5-PK AU

ME2-19+PE-SP-C1,6/0,5-1,5-PK AU	Contact insert-set
ME2-19+PE-SP-C1,6/0,5-1,5-PK AU	Housing size
ME2- 19+PE -SP-C1,6/0,5-1,5-PK AU	Number of contacts
ME2-19+PE- SP -C1,6/0,5-1,5-PK AU	SP: Pin; BP: Socket
ME2-19+PE-SP- C 1,6/0,5-1,5-PK AU	C: Clip; R: Retaining ring
ME2-19+PE-SP-C 1,6 /0,5-1,5-PK AU	Nom.-Ø pin (mm)
ME2-19+PE-SP-C1,6/ 0,5-1,5 -PK AU	Conductor cross section (mm ²)
ME2-19+PE-SP-C1,6/0,5-1,5- PK AU	PEEK
ME2-19+PE-SP-C1,6/0,5-1,5-PK AU	Surface

Carrier size	Conductor cross section		Number of poles	Nom.-Ø contact	Surface	Order No.	Type	Max. rated current	Rated voltage	
	mm ²	AWG								A
G2	0.5 – 1.5	20 – 16	19+PE	1.6		19.6651	ME2-19+PE-SP-C1,6/0,5-1,5-PK AU	16	150	
						19.6650	ME2-19+PE-BP-C1,6/0,5-1,5-PK AU			
	2.5 – 4	14 – 12	3+PE	3		19.6657	ME2-3+PE-SP-C3/2,5-4-PK AU	36	600	
						19.6656	ME2-3+PE-BP-C3/2,5-4-PK AU			
	4 – 6	12 – 10				19.6653	ME2-3+PE-SP-C3/4-6-PK AU	50		
						19.6652	ME2-3+PE-BP-C3/4-6-PK AU			
	35	2	1	10		19.6661	ME2-1-SP-R10/35-PK AU	150	600	
						19.6660 ²⁾	ME2-1-BP-R10/35-PK AU			
	50	1/0	19.6659	ME2-1-SP-R10/50-PK AU	180					
			19.6658 ²⁾	ME2-1-BP-R10/50-PK AU						
	70	2/0	19.6655	ME2-1-SP-R10/70-PK AU	200					
			19.6654 ²⁾	ME2-1-BP-R10/70-PK AU						
	G3	0.5 – 1.5	20 – 16	47+PE	1.6		19.6663	ME3-47+PE-SP-C1,6/0,5-1,5-PK AU	16	150
							19.6662	ME3-47+PE-BP-C1,6/0,5-1,5-PK AU		
2.5 – 4		14 – 12	9+PE	3		19.6669	ME3-9+PE-SP-C3/2,5-4-PK AU	36	600	
						19.6668	ME3-9+PE-BP-C3/2,5-4-PK AU			
			13+PE ¹⁾			19.6675	ME3-13+PE-SP3/2,5-4-PK AU	36		
						19.6674	ME3-13+PE-BP3/2,5-4-PK AU			
4 – 6		12 – 10	9+PE	6		19.6665	ME3-9+PE-SP-C3/4-6-PK AU	50	600	
						19.6664	ME3-9+PE-BP-C3/4-6-PK AU			
			13+PE ¹⁾			19.6677	ME3-13+PE-SP3/4-6-PK AU	50		
						19.6676	ME3-13+PE-BP3/4-6-PK AU			
10		8	3+PE	6		19.6671	ME3-3+PE-SP-C6/10-PK AU	80	600	
						19.6670	ME3-3+PE-BP-C6/10-PK AU			
16		6	19.6667	ME3-3+PE-SP-C6/16-PK AU	110					
			19.6666	ME3-3+PE-BP-C6/16-PK AU						
25		4	19.6673	ME3-3+PE-SP-C6/25-PK AU	135					
			19.6672	ME3-3+PE-BP-C6/25-PK AU						
0.5 – 0.75		26 – 18	4xNET1	1		19.9111	ME3-4NET-PK/S	5	24	
						19.9107	ME3-4NET-PK/B			

¹⁾ Mating compatibility with the standard (NBR) version

²⁾ No touch protection

HOUSINGS

Overview

	Housing size	Mating cycles	Page
Plastic housings			
	MGK1 – MGK4	10,000,000	76
Plastic housings, shielded, insulated			
	MGS1...-IS – MGS3...-IS MGS3...N-...	1,000,000	80
Metal housing, shielded			
	MGS1...-S	1,000,000	83
Metal housing			
	MGA2... – MGA3...	1,000,000	84

Note:

Housings out of stainless steel on request

Shielding principle

The MULTILAM serve as a contact element between the housings, providing continuity of the shield and an optimum 360° shielding effect.

For selected housings, the shield is connected via an EMC cable gland that is protected against touching by means of insulating sleeves.

Advantages (shielding):

- Secure BUS signal transfer (360° shielding)
- Ideal for Profinet and Ethernet applications (CAT5 and CAT6)
- Simple cabling with shielded cable gland

Advantages (plastic insulation):

- No electrical connection between housing and mounting panel
- Shield loops are already prevented on assembly

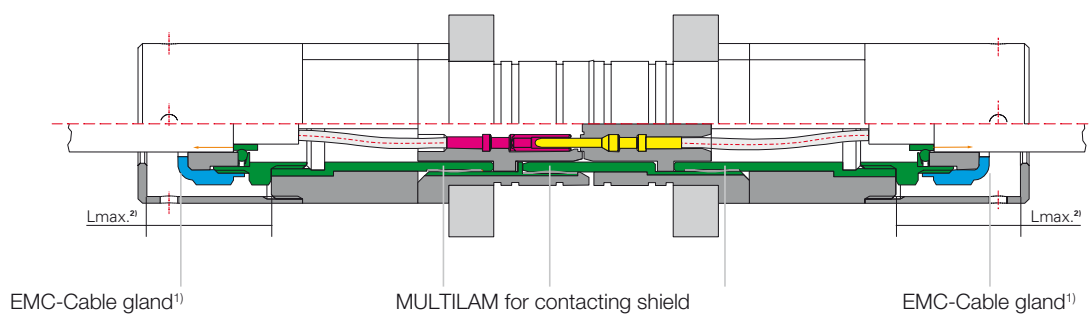

Continuous shield contacting

Plastic housing

Pin

Socket

¹⁾ EMC-threaded glands are supplied with selected housings. Please see ordering information

²⁾ If alternative glands are used, please observe the correct size Lmax:

Housing size 1: 25 mm
 Housing size 2: 31.5 mm
 Housing size 3: 32.5 mm

Plastic housings

Pin and socket housing MGK...

Fully insulated plastic housings of high-impact material. Unlike metal housings, they do not need to be earthed.

The standard housings are available in 4 different sizes. For size 3 a special housing for mounting a form shroud (page 80) is available.

The socket and pin housings each consist of two parts (front and rear part) which are

screwed together. The cylindrical front part of the housing serves for the positioning of the contact carrier and the square rear part for the insertion and mounting of the leads.

The strain relief on the housing is provided by the cable gland.

The cable lead-in may be in-line or right-angled. **Only plastic cable glands may be used.**

For multicouplings and docking systems the housings are incorporated in prepared mounting panels, see section "installation situation" page 90. A retaining ring is supplied for mounting in panels.

Depending on the panel thickness and panel spacing, spacer rings may be required, see pages 89 and 90.



Cable outlets: 2 (5 directions)

Type code example:

MGK1VB10-14+MGK1R-M20

MGK1VB10-14+MGK1R-M20	"Multi-pole" series
MGK1VB10-14+MGK1R-M20	Housings plastic
MGK1VB10-14+MGK1R-M20	Housing size
MGK1 VB 10-14+MGK1R-M20	VB: Front section of socket housing VS: Front section of pin housing
MGK1VB 10-14 +MGK1R-M20	Plate thickness (mm)
MGK1VB10-14+MGK1 R -M20	Back of housing
MGK1VB10-14+MGK1R- M20	Cable glands metric threads

Housing size	Order No.	Type	Cable gland		Spacers	Fits
			optional	not supplied		
MGK1...	18.0111	MGK1VB10-14+MGK1R-M20	M20		18.5652 ¹⁾	ME1... E1...
	18.0110	MGK1VS10-14+MGK1R-M20	18.5896			
	18.0101	MGK1VB10-14+MGK1R13		PG13		
	18.0100	MGK1VS10-14+MGK1R13				
MGK2...	18.0211	MGK2VB10-14+MGK2R-M25	M25		18.5633 ¹⁾	ME2... E2...
	18.0210	MGK2VS10-14+MGK2R-M25	15.5377		18.5632 ¹⁾	
	18.0201	MGK2VB10-14+MGK2R21		PG21	18.5633 ¹⁾	
	18.0200	MGK2VS10-14+MGK2R21			18.5632 ¹⁾	
MGK3...	18.0309	MGK3VB10-14+MGK3R-M25	M25		18.5617 ¹⁾	ME3... E3...
	18.0311	MGK3VS10-14+MGK3R-M25	15.5377		18.5618 ¹⁾	
	18.0308	MGK3VB10-14+MGK3R-M32	M32		18.5617 ¹⁾	
	18.0310	MGK3VS10-14+MGK3R-M32	15.5378		18.5618 ¹⁾	
	18.0303	MGK3VB10-14+MGK3R21		PG21	18.5617 ¹⁾	
	18.0302	MGK3VS10-14+MGK3R21			18.5618 ¹⁾	
	18.0301	MGK3VB10-14+MGK3R29		PG29	18.5617 ¹⁾	
	18.0300	MGK3VS10-14+MGK3R29			18.5618 ¹⁾	
MGK4...	18.0415	MGK4VB10-14+MGK4R-M50	M50		-	ME4...
	18.0414	MGK4VS10-14+MGK4R-M50	15.5373		18.5809 ²⁾	E4...

Special case in housing size 3

Both the pin as well as the socket contact carrier may be fitted into housing front part. Example of use: Power supply on the con-

sumer side, e.g. battery set for mobile power supply on tool.

Note:

In the case of the pin housing front part (picture left), an adapter ring (supplied) is needed for assembly.

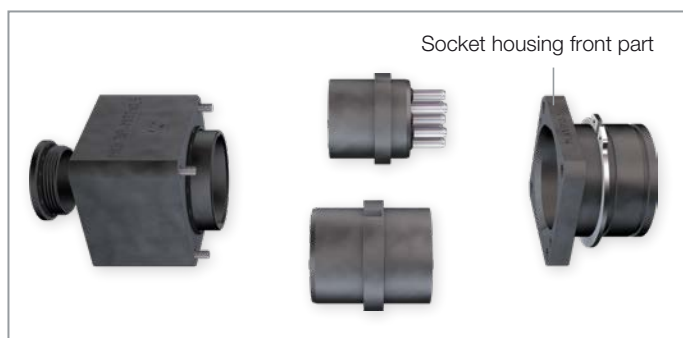
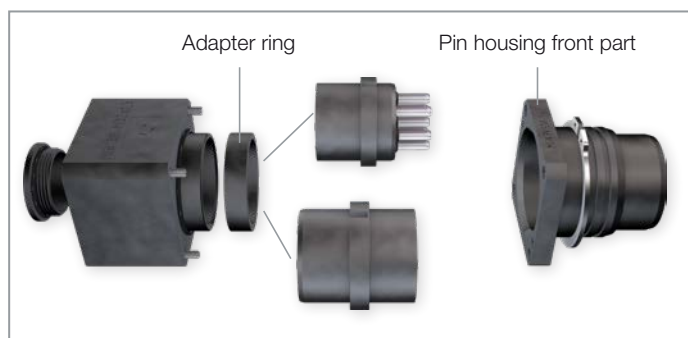

¹⁾ For plate spacing 13 mm, not supplied

²⁾ For plate spacing 37 mm, supplied



Assembly instructions MA202, MA203, MA303

www.staubli.com/electrical

Special pin and socket housings

For plate thickness 20 mm
and plate spacing 28 mm

In addition to our standard housings, we also offer special housings. Available in three sizes, with PG threads, fitting the

standard contact carriers (E...) and contact insert sets (ME...).

Only available on request.

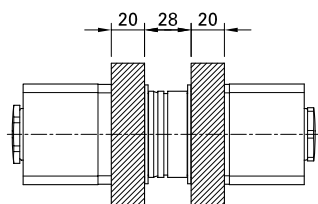

Housing size	Order No.	Socket housing	Pin housing	Short housing	Cable gland ¹⁾	Fits
G1	18.0103	×			PG16	ME1...
	18.0102		×			E1...
G2	18.0205	×			PG21	ME2...
	18.0204		×			E2...
G3	18.0319	×			PG29	ME3...
	18.0318		×			E3...
	18.0317	×		×	PG21	ME3...
	18.0316		×	×		E3...
	18.0321	×			PG21	ME3...
	18.0320		×			E3...

¹⁾ not supplied

Housing front parts

For form shroud

To save space, a shrink-on shroud may be used instead of a cubic rear housing (only in size 3). This enables the total length to be reduced in mated condition.

The shrink-on shrouds are available with either an axial or a right-angled cable outlet.



Housing size	Order No.	Type	Form shroud	Fits
			Axial	
-WST	18.0305	MGK3VB10-14+MGK3R-WST	30.0021 WST-TS 150 	ME3... E3...
	18.0304	MGK3VS10-14+MGK3R-WST	30.0021 WST-TS 150 	



Plastic housings, shielded, insulated

Pin and socket housing shielded/insulated MGS... -IS

These housings are used in all applications where continuous shielding contact is required.

If separation between the shield and earth connection is required, these are housing (MGS...-IS) to use.

The MULTILAM serve as a contact element between the housings, providing continuity of the shield and an optimum 360° shielding effect.

In selected housings the shield is connected via an EMC gland (Stäubli recommends:

Pflitsch "Iris UNI Dicht", if not supplied in delivery). EMC glands are protected against touching by means of insulating sleeves.

MGS1VS-90-M20-IS



MGS1VB-90-M20-IS



Cable outlet: 1 (90°)

Type code example:

MGS1VB-M20-IS/9-13

MGS1VB-M20-IS/9-13	"Multi-pole" series
MGS1VB-M20-IS/9-13	Shielded plastic housing
MGS1VB-M20-IS/9-13	Housing size
MGS1 VB -M20-IS/9-13	VB: Front section of socket housing VS: Front section of pin housing
MGS1VB- M20 -IS/9-13	Cable gland metric
MGS1VB-M20- IS /9-13	Insulated, shielded
MGS1VB-M20-IS/ 9-13	Cable outer Ø (min. – max.)

Housing size	Order No.	Type	EMC cable gland		For cable outside Ø	Right angled	Spacers ¹⁾	Fits
			without	with				
MGS1...-IS	18.0137	MGS1VB-90-M20-IS		x	7.0 – 10.5	x	18.5652	ME1... E1...
	18.0136	MGS1VS-90-M20-IS		x		x		
	18.0133	MGS1VB-M20-IS	x					
	18.0130	MGS1VS-M20-IS	x					
	18.0134	MGS1VB-M20-IS/7-10,5		x	7.0 – 10.5			
	18.0131	MGS1VS-M20-IS/7-10,5		x				
	18.0135	MGS1VB-M20-IS/9-13		x	9 – 13			
	18.0132	MGS1VS-M20-IS/9-13		x				
	18.0121	MGS1VB-R13-IS	x					
	18.0120	MGS1VS-R13-IS	x					
	18.0123	MGS1VB-R16-IS	x					
	18.0122	MGS1VS-R16-IS	x					
MGS2...-IS	18.0231	MGS2VB-M25-IS	x				18.5954	ME2... E2...
	18.0229	MGS2VS-M25-IS	x					
	18.0232	MGS2VB-M25-IS/9-13		x	9 – 13			
	18.0230	MGS2VS-M25-IS/9-13		x				
	18.0221	MGS2VB-R21-IS	x					
	18.0220	MGS2VS-R21-IS	x					

¹⁾ only for plate spacing 13 mm

Plastic housings, shielded, insulated

Warning note:

The new MGS3...N-... housings are not mating-compatible with the previous version! If upgrading, the pin and socket side need to be replaced by the new MGS3...N-... version.

The new housings are optimized in terms of insertion and withdrawal forces and therefore designed for a long service life.

Housing size	Order No.		Type	EMC cable gland		For cable outside Ø	Spacers ¹⁾	Fits
	NEW	OLD ²⁾		without	with			
MGS3...-IS	18.0350	18.0340	MGS3BN-M32-IS	×		14 –18	18.5675	ME3... E3...
	18.0353	18.0338	MGS3SN-M32-IS	×			18.5674	
	18.0351	18.0339	MGS3BN-M32-IS/14-18		×		18.5675	
	18.0354	18.0337	MGS3SN-M32-IS/14-18		×		18.5674	
	18.0352	18.0328	MGS3BN-R29-IS	×			18.5675	
	18.0355	18.0327	MGS3SN-R29-IS	×			18.5674	

MGS3SN...

MGS3BN...



Cable outlet: 1 (straight)

Important:

The drilling plan distinguishes between MGS3...-IS and MGK3... see page 94.

¹⁾ only for plate spacing 13 mm

²⁾ Spare parts, still available on request

Metal housing, shielded

Pin and socket housing shielded MGS...-S

With voltages > 60 V DC or > 30 V AC, the housing must be connected to the earth line (PE).

If EMC cable glands are used, the housing can also be used for shielding. It may be necessary to insulate it from the mounting panel.

EMC cable glands are not supplied in the delivery. (Stäubli recommends: Pflitsch "Iris UNI Dicht"). The cable outlet may be either axial or right-angled.

Note:

The shielding connection between the pin and the socket housing is via the contact carrier. The shield is laid on a contact pair (pin and socket contact), and thus an electrical connection is made.

Type code see page 80.



Cable outlets:
2 (5 directions)

Housing size	Order No.	Type	Cable gland		Spacers ¹⁾	Fits
			without	with		
MGS1...-S	18.0117	MGS1VB-10-14+MGS1R-M20	x		18.5652	ME1... E1...
	18.0116	MGS1VS-10-14+MGS1R-M20	x			
	18.0107	MGS1VB-R13-S	x			
	18.0106	MGS1VS-R13-S	x			

¹⁾ only for plate spacing 13 mm

Metal housing

Pin and socket housing MGA...

These aluminum housings are suitable for demanding areas of application, mostly but not exclusively in combination with contact carriers made from silicon or PEEK materials.

With voltages > 60 V DC or > 30 V AC, metal housings must be connected to the earth line (PE).

As well as metric and PG cable glands, NPT cable glands can also be used.

Note:

The housings listed below are designed for a plate spacing of 37 mm when mated. They fit both 10 mm and 14 mm mounting plates. Spacer rings (if required) are included in the delivery.



Housing size	Order No.	Type	Mounting plates	Cable gland ¹⁾		Fits
				Axial	90°	
			mm			
MGA2...	18.0240	MGA2B14-PG21	14	PG21	PG21	ME2... E2...
	18.0241	MGA2B14-NPT3/4	14	NPT3/4	NPT3/4	
	18.0242	MGA2B14-M25	14	M25×1,5	M25×1,5	
	18.0243	MGA2S10-PG21	10	PG21	PG21	
	18.0244	MGA2S14-PG21	14	PG21	PG21	
	18.0245	MGA2S10-NPT3/4	10	NPT3/4	NPT3/4	
	18.0246	MGA2S14-NPT3/4	14	NPT3/4	NPT3/4	
	18.0247	MGA2S10-M25	10	M25×1,5	M25×1,5	
18.0248	MGA2S14-M25	14	M25×1,5	M25×1,5		

¹⁾ Not supplied.

Housing size	Order No.	Type	Mounting plates	Cable gland ¹⁾		Fits
				Axial	90°	
			mm			
MGA3...	18.0360	MGA3B14-2PG	14	PG36	PG29	ME3... E3...
	18.0361	MGA3B14-NPT1	14	NPT1"	NPT1"	
	18.0362	MGA3B14-2M	14	M40×1,5	M32×1,5	
	18.0363	MGA3S10-2PG	10	PG36	PG29	
	18.0364	MGA3S14-2PG	14	PG36	PG29	
	18.0365	MGA3S10-NPT1	10	NPT1"	NPT1"	
	18.0366	MGA3S14-NPT1	14	NPT1"	NPT1"	
	18.0367	MGA3S10-2M	10	M40×1,5	M32×1,5	
	18.0368	MGA3S14-2M	14	M40×1,5	M32×1,5	

ASSEMBLY TOOLS

Insertion tool ME-...

Insertion tool	Nom.-Ø contact	Order No.	Type
ME-...	mm		
	1/1.2	18.3000	ME-WZ1/1,2
	1.5/1.57/2/2.36	18.3003	ME-WZ1,5/2
	1.6	18.3039	ME-CWZ1,6 ¹⁾
	3	18.3010	ME-WZ3
	5	18.3013	ME-WZ5
	6	18.3016	ME-WZ6
	8/11	18.3021	ME-WZ11/38

Extraction tools M...A-WZ..., MA-CWZ...

Extraction tool (pin)	Nom.-Ø contact	Order No.	Type
M...A-WZ..., MA-CWZ...	mm		
	1/1.2	18.3002	MSA-WZ1/1,2
	1.5/1.57	18.3005	MSA-WZ1,5
	1.5	18.3020	MSA-WZ1,5/109
	1.6	18.3037	MA-CWZ1,6 ¹⁾
	2	18.3009	MSA-WZ2
	2.36/3	18.3012	MSA-WZ3
	3	18.3036	MA-CWZ3 ¹⁾
	5	18.3015	MSA-WZ5
	6	18.3018	MSA-WZ6
	6	18.3038	MA-CWZ6 ¹⁾
8	18.3022	MSA-WZ8	
11	18.3014	MBA-WZ5	

Extraction tool (socket)	Nom.-Ø contact	Order No.	Type
M...A-WZ..., MA-CWZ...	mm		
	1/1.2	18.3001	MBA-WZ1/1,2
	1.5/1.57	18.3004	MBA-WZ1,5
	1.5	18.3019	MBA-WZ1,5/109
	1.6	18.3037	MA-CWZ1,6 ¹⁾
	2/2.36	18.3008	MBA-WZ2
	3	18.3011	MBA-WZ3
	3	18.3036	MA-CWZ3 ¹⁾
	5	18.3014	MBA-WZ5
	6/8	18.3017	MBA-WZ6
	6	18.3038	MA-CWZ6 ¹⁾
	11	18.3022	MSA-WZ8

¹⁾ For PEEK carriers, other tools see MA303



Assembly instructions MA202, MA203, MA205, MA303

www.staubli.com/electrical

Crimping tools

Recommended by Stäubli

- Leads from 0.14 mm² to 4 mm²: Crimping tool M-CZ

- Leads from 6 mm² to 35 mm²: Crimping tool M-PZ13 (small volumes)

- Leads from 16 mm² to 70 mm²: crimping tool CZK2-... (series assembly)

CZK2-...



MTB9-16-50



MTB14,5-50-50

M-PZ13



MES-PZ-T...

M-CZ



MES-CZ

MES-CZ1,5/2

Conductor cross section		Nom.-Ø contact	Order No.	Type	Designation	MA
mm ²	AWG	mm				

For power contacts

25/35/38	4/~2	6/8/10/11	18.3111	CZK2-230	Crimping tool case (Battery charger 230 V) see Flyer „Crimping Tool Case CZK2“	MA306
			18.3112	CZK2-110	Crimping tool case (Battery charger 110 V) see Flyer „Crimping Tool Case CZK2“	

Optional accessories

16	6		18.3029	MTB9-16-50	Crimping die	MA306
50	1/0		18.3025	MTB14,5-50-50	Crimping die	
–	–	–	18.3700	M-PZ13	Crimping tool	MA224
6	10	5/6	18.3701	MES-PZ-TB5/6	Crimping die for M-PZ13	
10	8	5/6	18.3702	MES-PZ-TB8/10	Crimping die for M-PZ13	
16	6	6	18.3703	MES-PZ-TB9/16	Crimping die for M-PZ13	
25	4	6/8/11	18.3704	MES-PZ-TB11/25	Crimping die for M-PZ13	
35	2	8/10/11	18.3705	MES-PZ-TB13/35	Crimping die for M-PZ13	

For signal contacts

–	–	–	18.3800	M-CZ	Crimping tool	MA085
0.14 – 4	26 – 12	1 – 3	18.3801	MES-CZ	Locator to M-CZ	
0.5 – 1.5	20 – 16	1.5/1.6/2	18.3802	MES-CZ1,5/2	Locator to M-CZ	

ACCESSORIES

Blind plugs

Vacant contact cavities must be fitted with blind plugs in order to ensure longitudinal watertightness and mechanical stability.

The blind plugs are coloured differently, so they can be easily distinguished.

Nom.-Ø contact mm	Order No.	Type		Color
1	18.5506	MVS-1/1		white
1.5/1.57/2	18.5500	MVS-1,5/2		blue
3	18.5501	MVS-3		yellow
5	18.5502	MVS-5		white
6	18.5503	MVS-6		black
8	18.5505	MVS-8		

Cable glands made of polyamide (PA)

These polyamide (PA) cable glands are designed as accessories for our plastic housings (MGK1... to MGK4...).

The use of the following cable glands in combination with our plastic housings eliminates the need for earthing (making assembly easier).

Note:

1 blind plug is included in the delivery (see page 8)

Order No.	Type		Housing size	Thread	For cable outside Ø mm
18.5896	K-VSH M20X1,5 6-12 PA		G1	M20	6 – 12
15.5377	K-VSH M25X1,5 9-16 PA		G2 + G3	M25	9 – 16
15.5378	K-VSH M32X1,5 18-25 PA		G3	M32	18 – 25
15.5373	K-VSH M50X1,5 27-35 PA		G4	M50	26 – 35

Spacers

By means of the spacer rings, the housing es and panel spacings in mated condition, can be adapted to different panel thickness- see installation situation on page 90.

Carrier size	Order No.	Type	Fits	Socket side	Pin side
G1	18.5652	DST-RG GR. 1/10	MGK1... MGS1...		
G2	18.5633	DST-RG GR. 2/12 BU	MGK2... MGS2...-IS		-
	18.5632	DST-RG GR. 2/8 STI		-	
G3	18.5618	DST-RG GR. 3/14 BU	MGK3...		-
	18.5617	DST-RG GR. 3/6 STI		-	
	18.5675	DST-RG-3S/14BU-IS	MGS3...-IS		-
	18.5674	DST-RG-3S/6STI-IS		-	

APPENDIX

Admissible installation situation

Stäubli DuraDock connectors have been designed for mounting inside a plate. Depending on the thickness of the plate (e.g.

14 mm and/or 10 mm) and the distance between the plates (e.g. 37 mm or 13 mm in mated condition) spacer rings (see table

page 89) may be required. This allows various combinations.

Housings		Plate spacing 37 mm		Plate spacing 13 mm	
		Plate thicknesses		Plate thicknesses	
Size	Type	Socket housing	Pin housing	Socket housing	Pin housing
		14 mm	10 mm	14 mm	14 mm
1	MGK1...	no spacing ring		18.5652	18.5652
	MGS1...-IS				
	MGS1...-S				
2	MGK2...	no spacing ring		18.5633	18.5632
	MGS2...-IS				
3	MGK3...	no spacing ring		18.5618	18.5617
	MGS3...-IS			18.5675	18.5674
4	MGK4...	no spacing ring	supplied		

Plate spacing 37 mm (MGK...)

Size 1
MGK1...

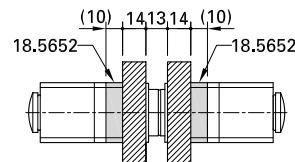
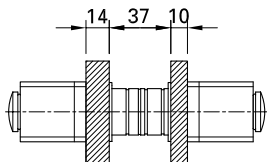

Size 2
MGK2...

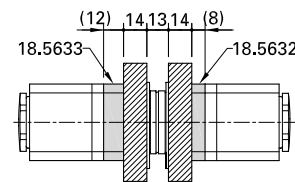
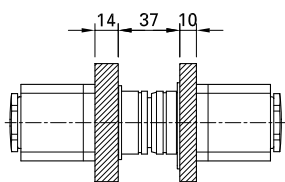

Size 3
MGK3...

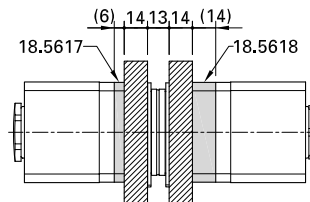
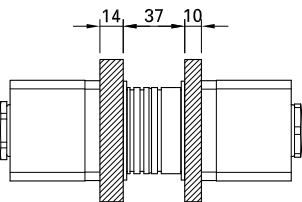

Size 4
MGK4...

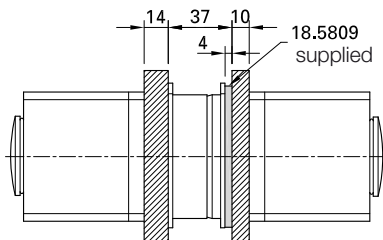
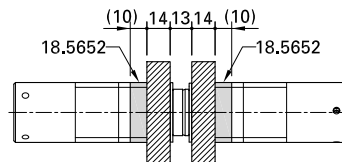
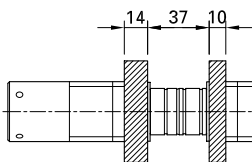
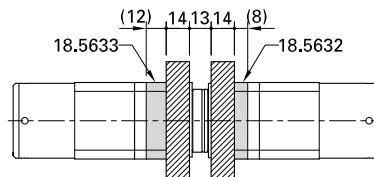
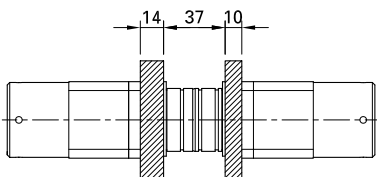

Plate spacing 37 mm (MGS...-IS)

Size 1
MGS1...-IS



Size 2
MGS2...-IS



Size 3
MGS3...-IS

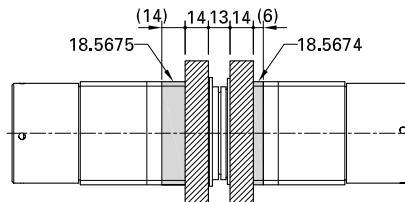
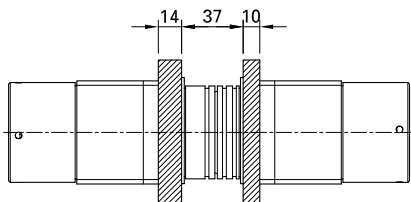
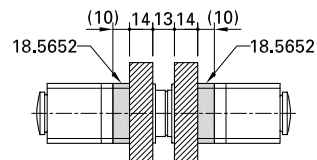
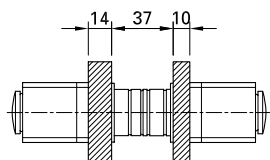

Plate spacing 37 mm (MGS...)

Size 1
MGS1...-S



Outer dimensions

Plastic housings MGK...

MGK1VB10-14+MGK1R-M20

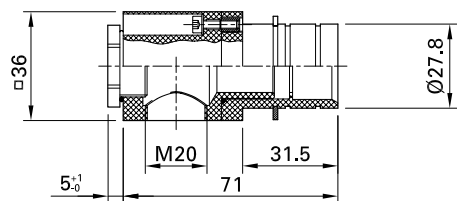

MGK1VS10-14+MGK1R-M20

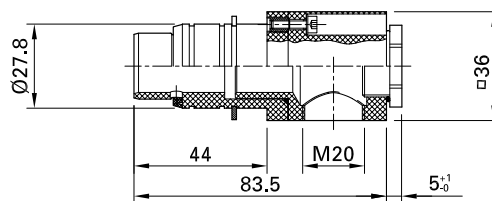

MGK2VB10-14+MGK2R-M25

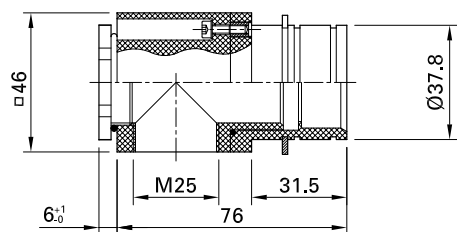

MGK2VS10-14+MGK2R-M25

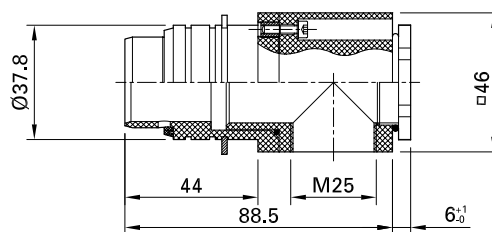

MGK3VB10-14+MGK3R-M...

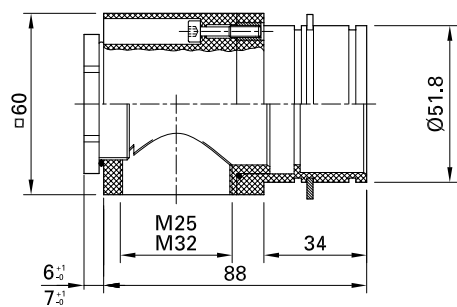

MGK3VS10-14+MGK3R-M...

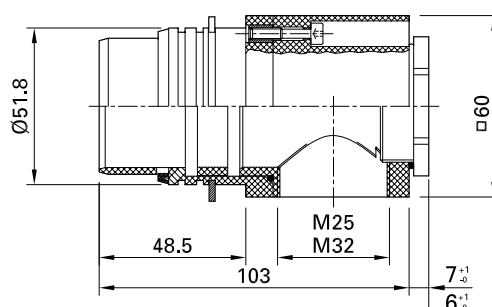

MGK4VB10-14+MGK4R-M50

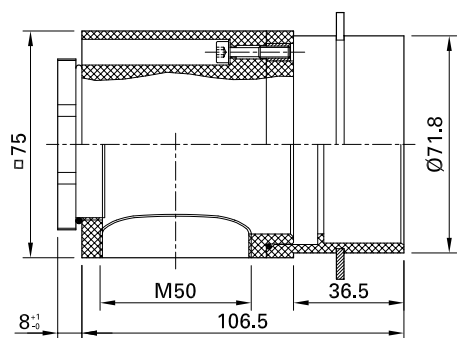

MGK4VS10-14+MGK4R-M50

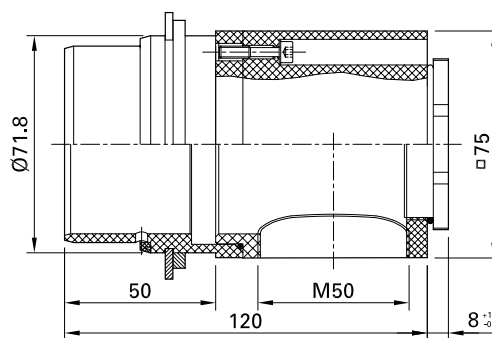

Plastic housings, shielded, insulated MGS...-IS

MGS1VB-M20-IS...

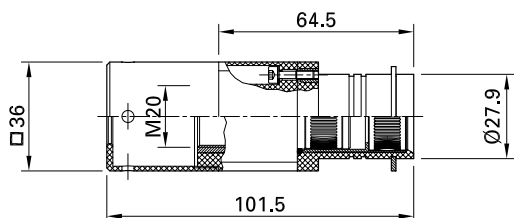

MGS1VS-M20-IS...

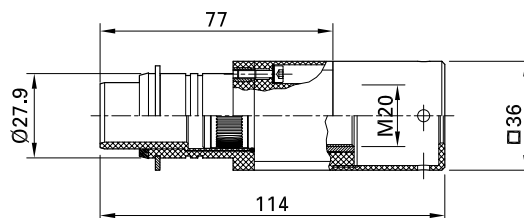

MGS2VB-M25-IS...

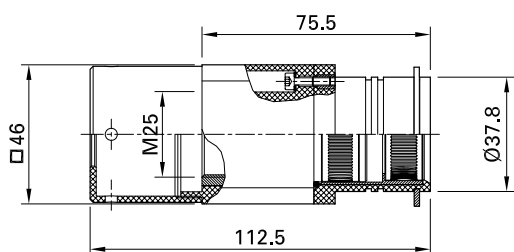

MGS2VS-M25-IS...

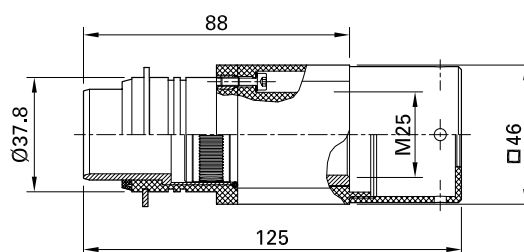

MGS3VB-M32-IS...

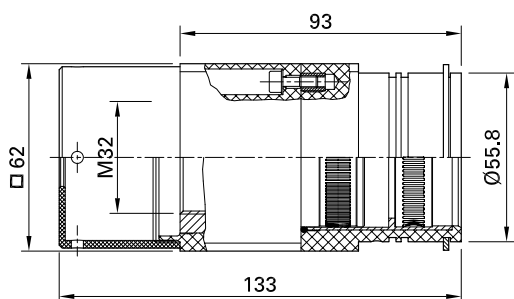

MGS3VS-M32-IS...

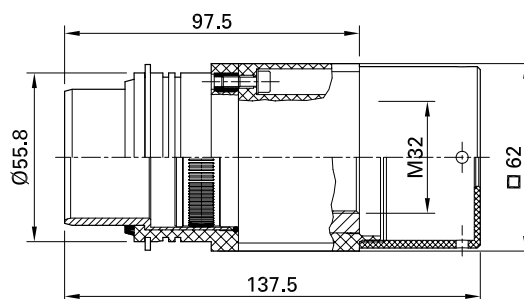

Metal housing, shielded MGS...-S

MGS1VB-M20

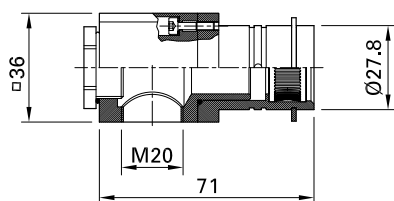

MGS1VS-M20

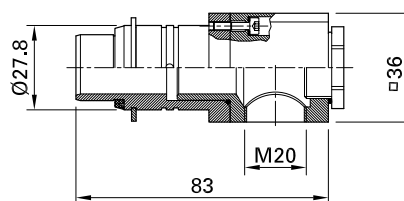

Drilling plans

Drilling plans for mounting plates. View from front of pin housing. Slotted pins are included in the delivery of the housing (see Installation situation, page 9).

ed in the delivery of the housing (see Installation situation, page 9).

MGK1...
MGS1...-IS
MGS1...-S

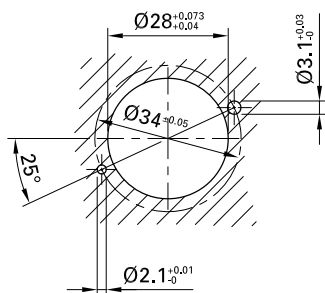

MGK2...
MGS2...-IS

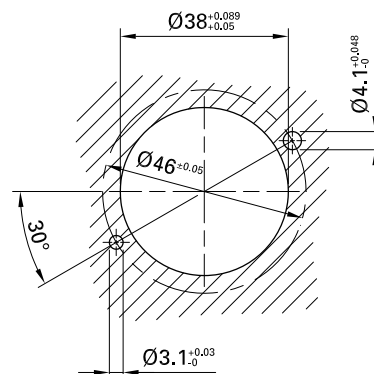

MGK3...

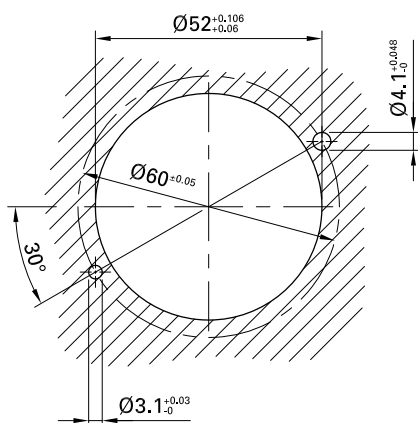

MGS3...-IS

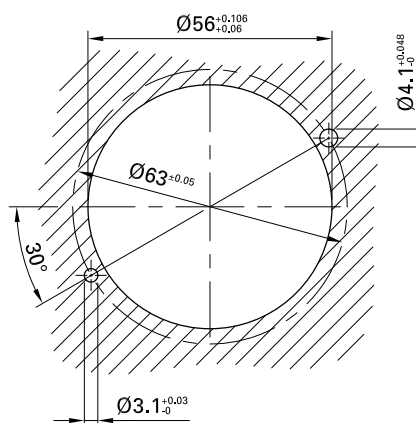

MGK4...

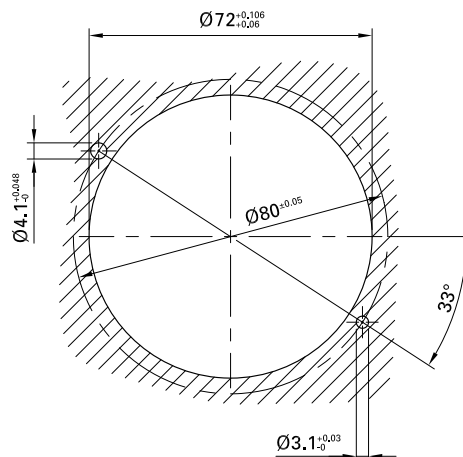
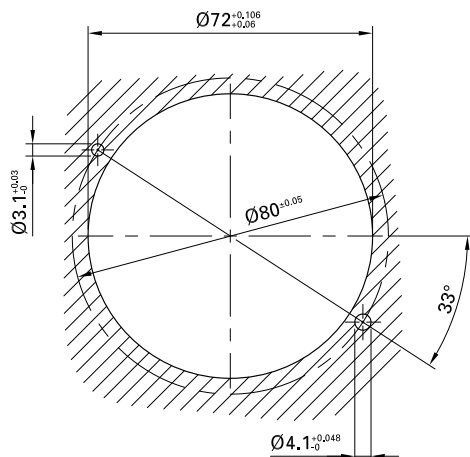

Derating diagrams

The current capacity of a connection is limited by the thermal capacity of its contact, connecting and insulating materials. The derating diagram shows the continuous current (not intermittent) that flows through all the contact elements of a connector at one

time, whereby the max. temperature limit is not exceeded.

Calibration and test method according to DIN 41640/Part 3.

The derating diagram values are valid for the connection (see standard EN 60204).

The permissible current load of the cables can be seen in DIN VDE 0298-4 and DIN EN 60204-1, IEC 60204-1.

NBR/CR: Cable 0.25 mm² & 0.5 mm²

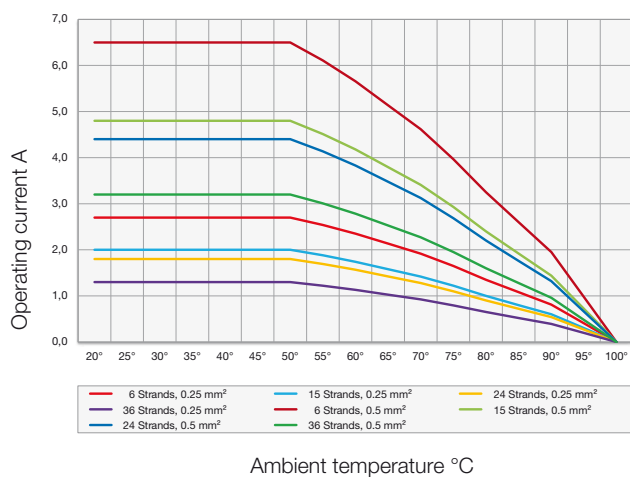

NBR/CR: Cable 0.75 mm² & 1 mm²

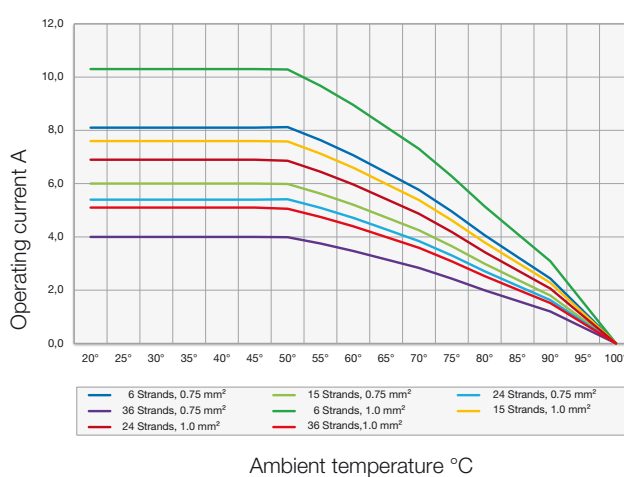

NBR/CR: Cable 1.5 mm²

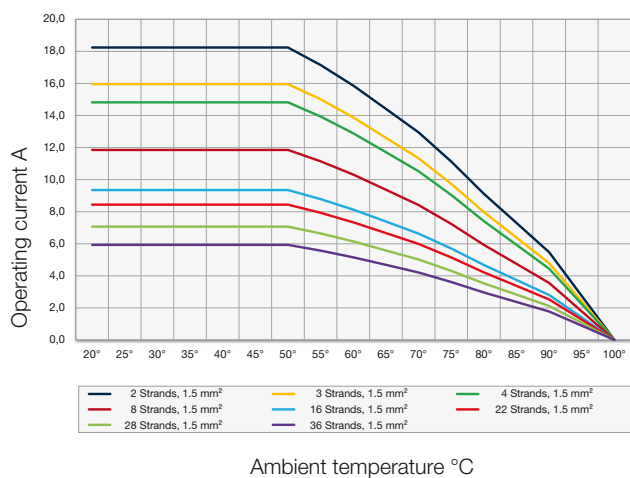

NBR/CR: Cable 2.5 mm² & 4 mm²

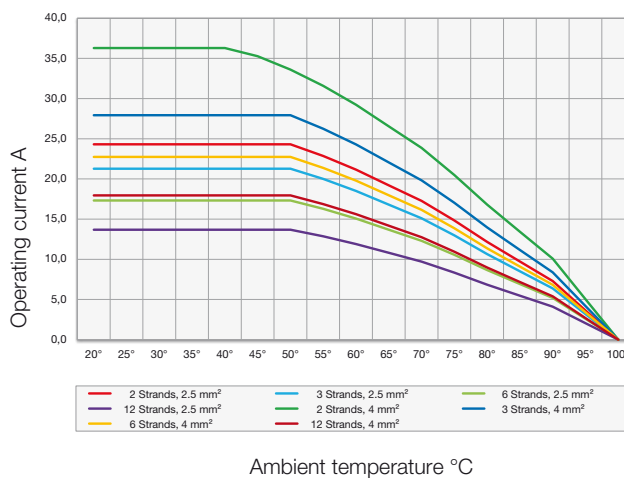

NBR/CR: Cable 6 mm² & 10 mm²

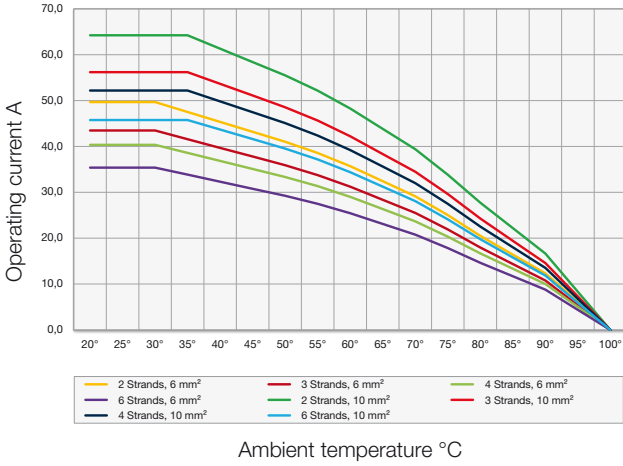

NBR/CR: Cable 16 mm², 25 mm², 35 mm² & 50 mm²

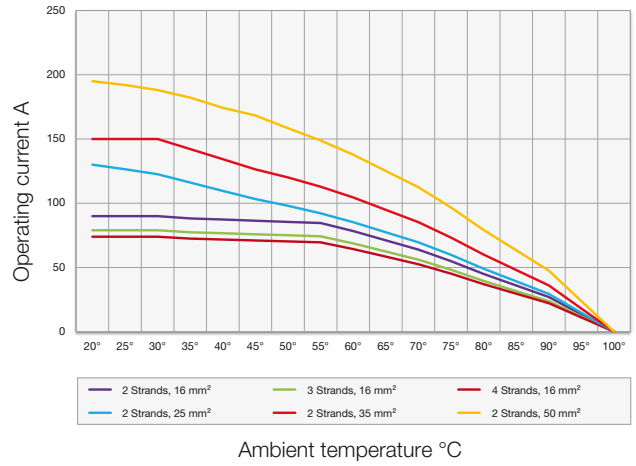

PEEK: Cable 1.5 mm², 2.5 mm², 6 mm², 10 mm² & 35 mm²

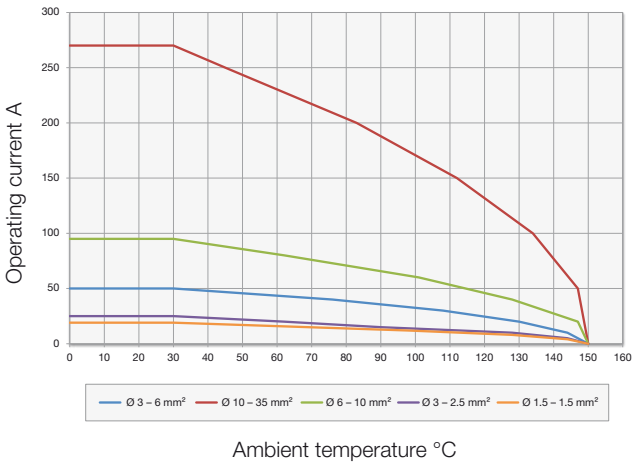

SIL: Cable 0.25 mm², 0.5 mm² & 0.75 mm²

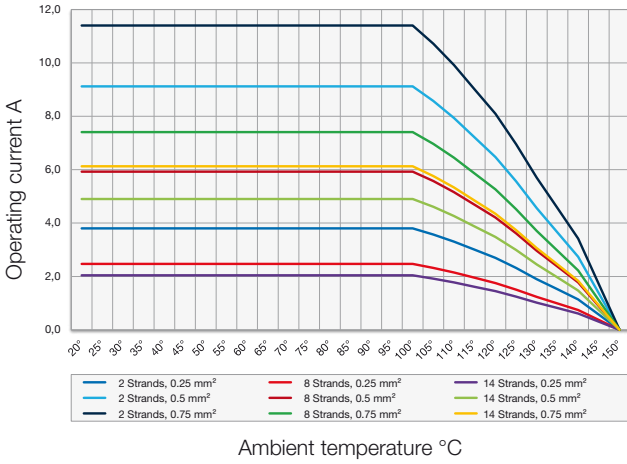

SIL: Cable 1 mm² & 1.5 mm²

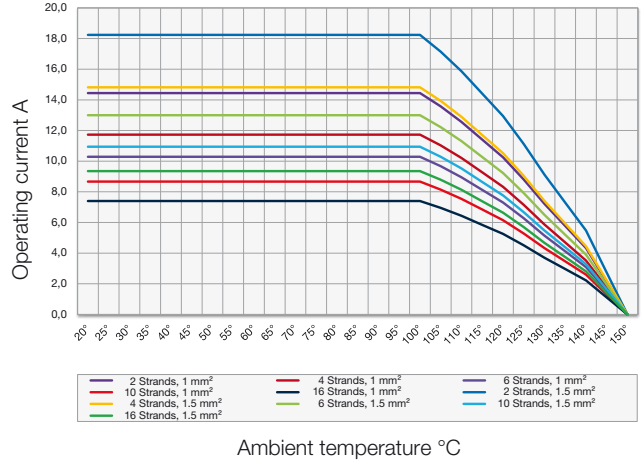

SIL: Cable 2.5 mm² & 4 mm²

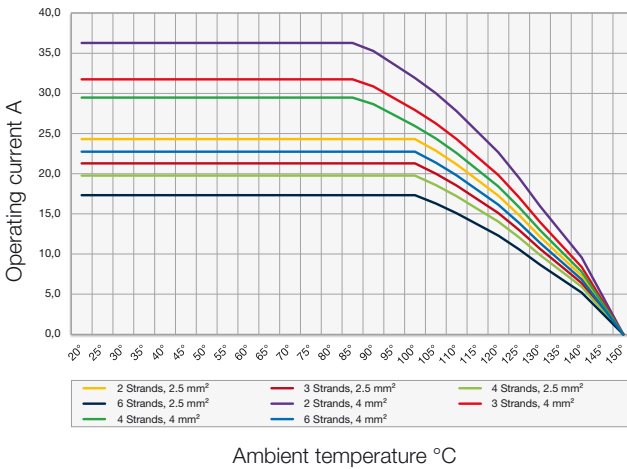

SIL: Cable 6 mm² & 10 mm²

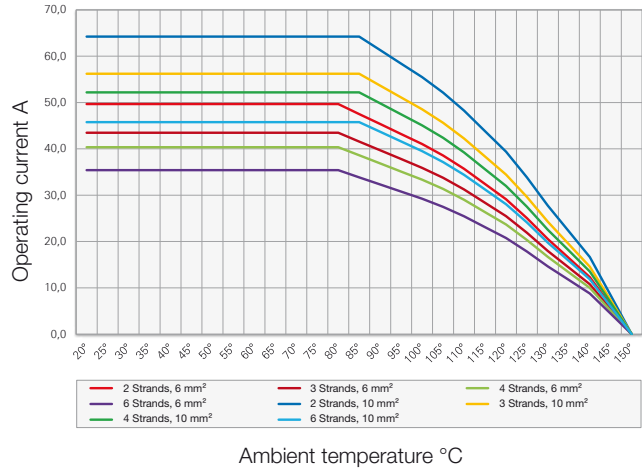

Index

Sorted by type

Type	Page
BP1/1	28, 36
BP1/1 AU	28, 34, 36
BP1,5/0,5-1,5	28, 34, 36
BP1,5/0,5-1,5 AU	28, 34, 36
BP1,5/0,14-0,5	28, 36
BP1,5/0,14-0,5 AU	28, 34, 36
BP2/0,5-1,5	28, 40
BP2/0,5-1,5 AU	28, 40
BP2/2,5	40
BP2/2,5 AU	40
BP3/2,5-4	40
BP3/2,5-4 AU	40
BP3/2,5-4(K)	36, 40
BP3/2,5-4(K) AU	36, 40
BP5/6	38, 42
BP5/6 AU	38, 42
BP5/10	38, 42
BP5/10 AU	38, 42
BP6/6	42
BP6/6 AU	42
BP6/10	42
BP6/10 AU	42
BP6/16	42
BP6/16 AU	42
BP6/25	42
BP6/25 AU	42
BP8/25	44
BP8/35	44
BP11/25	38, 44
BP11/35-38	38, 44
BP11/50	38, 44
BP-C1,6/0,5-1,5 AU	46
BP-C3/2,5-4 AU	46
BP-C3/4-6 AU	46
BP-C6/10 AU	46
BP-C6/16 AU	46
BP-C6/25 AU	46
BP-R10/35 AU	46
BP-R10/50 AU	46
BP-R10/70 AU	46
CT-NET/B	46
CT-NET/S	46
CZK2-110	87
CZK2-230	87

Type	Page
DBP2/0,5-1,5 AU	32
DBP2-AL/0,14-0,5	32
DBP2-CO/0,14-0,5	32
DBP2-CR/0,14-0,5	32
DBP2-CU/0,14-0,5	32
DBP2-FE/0,14-0,5	32
DBP2-NICRSI/0,14-0,5	32
DBP2-NISI/0,14-0,5	32
DSP2/0,5-1,5 AU	32
DSP2-AL/0,14-0,5	32
DSP2-CO/0,14-0,5	32
DSP2-CR/0,14-0,5	32
DSP2-CU/0,14-0,5	32
DSP2-FE/0,14-0,5	32
DSP2-NICRSI/0,14-0,5	32
DSP2-NISI/0,14-0,5	32
DST-RG-3S/6STI-IS	89
DST-RG-3S/14BU-IS	89
DST-RG GR. 1/10	89
DST-RG GR. 2/8 STI	89
DST-RG GR. 2/12 BU	89
DST-RG GR. 3/6 STI	89
DST-RG GR. 3/14 BU	89
E1-2PE+9/B	52, 53
E1-2PE+9/S	52, 53
E1-2PE/B	54
E1-2PE/S	54
E1-6PE/B	51, 52, 54
E1-6PE/S	51, 52, 54
E1-18PE/B	51, 52
E1-18PE/S	51, 52
E2-1-PK/B	59
E2-1-PK/S	59
E2-3PE+4/B	53
E2-3+PE+4/B SIL	57
E2-3PE+4/S	53
E2-3+PE+4/S SIL	57
E2-3PE-PK/B	59
E2-3PE-PK/S	59
E2-6PE/B	54
E2-6PE/B SIL	57
E2-6PE/S	54
E2-6PE/S SIL	57
E2-15PE/B	51, 52, 54

Type	Page
E2-15PE/B SIL	57
E2-15PE/S	51, 52, 54
E2-15PE/S SIL	57
E2-19PE-PK/B	59
E2-19PE-PK/S	59
E3-2PE/B	54, 55
E3-2PE/B8	54, 55
E3-2PE/S	54, 55
E3-2PE/S8	54, 55
E3-3PE-PK/B	59
E3-3PE-PK/S	59
E3-4NET-PK/B	59
E3-4NET-PK/S	59
E3-4PE/B	54, 55
E3-4PE/S	54, 55
E3-6PE/B	54, 55
E3-6PE/B SIL	57
E3-6PE/S	54, 55
E3-6PE/S SIL	57
E3-9PE-PK/B	59
E3-9PE-PK/S	59
E3-13PE/B	54
E3-13PE-PK/B	59
E3-13PE-PK/S	59
E3-13PE/S	54
E3-24PE/B	51, 52
E3-24PE/S	51, 52
E3-27/B	51, 52
E3-27/S	51, 52
E3-36PE/B	51, 52, 54
E3-36PE/B2,5-CR	56
E3-36PE/B2,5-SIL	57
E3-36PE/S	51, 52, 54
E3-36PE/S2,5-CR	56
E3-36PE/S2,5-SIL	57
E3-47PE-PK/B	59
E3-47PE-PK/S	59
E4-2PE+6/B	53
E4-2PE+6/S	53
E4-2PE/B	55
E4-2PE/S	55
E4-70/2PE/B	51, 52
E4-70/2PE/S	51, 52
K-VSH M20X1,5 6-12 PA	88

Type	Page
K-VSH M25X1,5 9-16 PA	88
K-VSH M32X1,5 18-25 PA	88
K-VSH M50X1,5 27-35 PA	88
MA-CWZ1,6	86
MA-CWZ3	86
MA-CWZ6	86
MBA-WZ1/1,2	86
MBA-WZ1,5	86
MBA-WZ1,5/109	86
MBA-WZ2	86
MBA-WZ3	86
MBA-WZ5	86
MBA-WZ6	86
M-CZ	87
ME1-2+PE-BP1,5/0,5-1,5+9BP1/1K	64
ME1-2+PE-BP3/2,5-4(K)	67
ME1-2+PE-BP3/2,5-4(K) AU	67
ME1-2+PE-SP1,5/0,5-1,5+9SP1/1K	64
ME1-2+PE-SP3/2,5-4(K)	67
ME1-2+PE-SP3/2,5-4(K) AU	67
ME1-6+PE-BP1,5/0,5-1,5	63
ME1-6+PE-BP1,5/0,5-1,5 AU	63
ME1-6+PE-BP2/0,5-1,5	63, 67
ME1-6+PE-BP2/0,5-1,5 AU	63, 67
ME1-6+PE-BP2/2,5	63
ME1-6+PE-BP2/2,5 AU	63
ME1-6+PE-SP1,5/0,5-1,5	63
ME1-6+PE-SP1,5/0,5-1,5 AU	63
ME1-6+PE-SP2/0,5-1,5	63, 67
ME1-6+PE-SP2/0,5-1,5 AU	63, 67
ME1-6+PE-SP2/2,5	63
ME1-6+PE-SP2/2,5 AU	63
ME1-18+PE-BP1/1	63
ME1-18+PE-BP1/1 AU	63
ME1-18+PE-SP1/1	63
ME1-18+PE-SP1/1 AU	63
ME2-1-BP-R10/35-PK AU	73
ME2-1-BP-R10/50-PK AU	73
ME2-1-BP-R10/70-PK AU	73
ME2-1-SP-R10/35-PK AU	73
ME2-1-SP-R10/50-PK AU	73
ME2-1-SP-R10/70-PK AU	73
ME2-3+PE+4/B SIL	71
ME2-3+PE+4/S SIL	71

Type	Page
ME2-3+PE-BP3/2,5-4(K)+4BP1,5/0,5-1,5	64
ME2-3+PE-BP-C3/2,5-4-PK AU	73
ME2-3+PE-BP-C3/4-6-PK AU	73
ME2-3+PE-SP3/2,5-4(K)+4SP1,5/0,5-1,5	64
ME2-3+PE-SP-C3/2,5-4-PK AU	73
ME2-3+PE-SP-C3/4-6-PK AU	73
ME2-4+PE-BP3/2,5-4(K)	67
ME2-4+PE-BP3/2,5-4(K) AU	67
ME2-4+PE-SP3/2,5-4(K)	67
ME2-4+PE-SP3/2,5-4(K) AU	67
ME2-6+PE-BP3/2,5-4(K)	67
ME2-6+PE-BP3/2,5-4(K) AU	67
ME2-6PE/B SIL	71
ME2-6+PE-SP3/2,5-4(K)	67
ME2-6+PE-SP3/2,5-4(K) AU	67
ME2-6PE/S SIL	71
ME2-15+PE-BP1,5/0,5-1,5	63
ME2-15+PE-BP1,5/0,5-1,5 AU	63
ME2-15+PE-BP2/0,5-1,5	63, 67
ME2-15+PE-BP2/0,5-1,5 AU	63, 67
ME2-15PE/B SIL	71
ME2-15+PE-SP1,5/0,5-1,5	63
ME2-15+PE-SP1,5/0,5-1,5 AU	63
ME2-15+PE-SP2/0,5-1,5	63, 67
ME2-15+PE-SP2/0,5-1,5 AU	63, 67
ME2-15PE/S SIL	71
ME2-19+PE-BP-C1,6/0,5-1,5-PK AU	73
ME2-19+PE-SP-C1,6/0,5-1,5-PK AU	73
ME3-2+PE-BP6/10	69
ME3-2+PE-BP6/16	69
ME3-2+PE-BP6/25	69
ME3-2+PE-BP8/25	69
ME3-2+PE-BP8/35	69
ME3-2+PE-SP6/10	69
ME3-2+PE-SP6/16	69
ME3-2+PE-SP6/25	69
ME3-2+PE-SP8/25	69
ME3-2+PE-SP8/35	69
ME3-3+PE-BP-C6/10-PK AU	73
ME3-3+PE-BP-C6/16-PK AU	73
ME3-3+PE-BP-C6/25-PK AU	73
ME3-3+PE-SP-C6/10-PK AU	73
ME3-3+PE-SP-C6/16-PK AU	73
ME3-3+PE-SP-C6/25-PK AU	73
ME3-4NET-PK/B	73
ME3-4NET-PK/S	73

Type	Page
ME3-4+PE-BP6/10	69
ME3-4+PE-BP6/16	69
ME3-4+PE-SP6/10	69
ME3-4+PE-SP6/16	69
ME3-6+PE-BP5/6	69
ME3-6+PE-BP5/10	69
ME3-6PE/B SIL	71
ME3-6+PE-SP5/6	69
ME3-6+PE-SP5/10	69
ME3-6PE/S SIL	71
ME3-9+PE-BP-C3/2,5-4-PK AU	73
ME3-9+PE-BP-C3/4-6-PK AU	73
ME3-9+PE-SP-C3/2,5-4-PK AU	73
ME3-9+PE-SP-C3/4-6-PK AU	73
ME3-13+PE-BP3/2,5-4	67
ME3-13+PE-BP3/2,5-4 AU	67
ME3-13+PE-BP3/2,5-4-PK AU	73
ME3-13+PE-BP3/4-6-PK AU	73
ME3-13+PE-SP3/2,5-4	67
ME3-13+PE-SP3/2,5-4 AU	67
ME3-13+PE-SP3/2,5-4-PK AU	73
ME3-13+PE-SP3/4-6-PK AU	73
ME3-24+PE-BP1,5/0,5-1,5	63
ME3-24+PE-BP1,5/0,5-1,5 AU	63
ME3-24+PE-SP1,5/0,5-1,5	63
ME3-24+PE-SP1,5/0,5-1,5 AU	63
ME3-27-BP1,5/0,5-1,5	63
ME3-27-BP1,5/0,5-1,5 AU	63
ME3-27-SP1,5/0,5-1,5	63
ME3-27-SP1,5/0,5-1,5 AU	63
ME3-36+PE-BP1,5/0,5-1,5	63
ME3-36+PE-BP1,5/0,5-1,5 AU	63
ME3-36+PE-BP2/2,5-CR	70
ME3-36+PE-BP2/2,5-SIL AU	71
ME3-36+PE-SP1,5/0,5-1,5	63
ME3-36+PE-SP1,5/0,5-1,5 AU	63
ME3-36+PE-SP2/2,5-CR	70
ME3-36+PE-SP2/2,5-SIL AU	71
ME3-47+PE-BP-C1,6/0,5-1,5-PK AU	73
ME3-47+PE-SP-C1,6/0,5-1,5-PK AU	73
ME4-2+PE-BP11/25+50	64, 69
ME4-2+PE-BP11/35-38	64, 69
ME4-2+PE-SP11/25+50	64, 69
ME4-2+PE-SP11/35-38	64, 69
ME4-70+2PE-BP1,5/0,5-1,5	63
ME4-70+2PE-BP1,5/0,5-1,5 AU	63

Type	Page
ME4-70+2PE-SP1,5/0,5-1,5	63
ME4-70+2PE-SP1,5/0,5-1,5 AU	63
ME-CWZ1,6	86
MES-CZ	87
MES-CZ1,5/2	87
MES-PZ-TB5/6	87
MES-PZ-TB8/10	87
MES-PZ-TB9/16	87
MES-PZ-TB11/25	87
MES-PZ-TB13/35	87
ME-WZ1/1,2	86
ME-WZ1,5/2	86
ME-WZ3	86
ME-WZ5	86
ME-WZ6	86
ME-WZ11/38	86
MGA2B14-M25	84
MGA2B14-NPT3/4	84
MGA2B14-PG21	84
MGA2S10-M25	84
MGA2S10-NPT3/4	84
MGA2S10-PG21	84
MGA2S14-M25	84
MGA2S14-NPT3/4	84
MGA2S14-PG21	84
MGA3B14-2M	85
MGA3B14-2PG	85
MGA3B14-NPT1	85
MGA3S10-2M	85
MGA3S10-2PG	85
MGA3S10-NPT1	85
MGA3S14-2M	85
MGA3S14-2PG	85
MGA3S14-NPT1	85
MGK1VB10-14+MGK1R13	77
MGK1VB10-14+MGK1R-M20	77
MGK1VS10-14+MGK1R13	77
MGK1VS10-14+MGK1R-M20	77
MGK2VB10-14+MGK2R21	77
MGK2VB10-14+MGK2R-M25	77
MGK2VS10-14+MGK2R21	77
MGK2VS10-14+MGK2R-M25	77
MGK3VB10-14+MGK3R21	77
MGK3VB10-14+MGK3R29	77
MGK3VB10-14+MGK3R-M25	77
MGK3VB10-14+MGK3R-M32	77

Type	Page
MGK3VB10-14+MGK3R-WST	79
MGK3VS10-14+MGK3R21	77
MGK3VS10-14+MGK3R29	77
MGK3VS10-14+MGK3R-M25	77
MGK3VS10-14+MGK3R-M32	77
MGK3VS10-14+MGK3R-WST	79
MGK4VB10-14+MGK4R-M50	77
MGK4VS10-14+MGK4R-M50	77
MGS1VB-10-14+MGS1R-M20	83
MGS1VB-90-M20-IS	81
MGS1VB-M20-IS	81
MGS1VB-M20-IS/7-10,5	81
MGS1VB-M20-IS/9-13	81
MGS1VB-R13-IS	81
MGS1VB-R13-S	83
MGS1VB-R16-IS	81
MGS1VS-10-14+MGS1R-M20	83
MGS1VS-90-M20-IS	81
MGS1VS-M20-IS	81
MGS1VS-M20-IS/7-10,5	81
MGS1VS-M20-IS/9-13	81
MGS1VS-R13-IS	81
MGS1VS-R13-S	83
MGS1VS-R16-IS	81
MGS2VB-M25-IS	81
MGS2VB-M25-IS/9-13	81
MGS2VB-R21-IS	81
MGS2VS-M25-IS	81
MGS2VS-M25-IS/9-13	81
MGS2VS-R21-IS	81
MGS3BN-M32-IS	82
MGS3BN-M32-IS/14-18	82
MGS3BN-R29-IS	82
MGS3SN-M32-IS	82
MGS3SN-M32-IS/14-18	82
MGS3SN-R29-IS	82
M-PZ13	87
MSA-WZ1/1,2	86
MSA-WZ1,5	86
MSA-WZ1,5/109	86
MSA-WZ2	86
MSA-WZ3	86
MSA-WZ5	86
MSA-WZ6	86
MSA-WZ8	86
MTB9-16-50	87

Type	Page
MTB14,5-50-50	87
MVS-1/1	88
MVS-1,5/2	88
MVS-3	88
MVS-5	88
MVS-6	88
MVS-8	88
SP1/1	28, 36
SP1/1 AU	28, 34, 36
SP1,5/0,5-1,5	28, 34, 36
SP1,5/0,5-1,5 AU	28, 34, 36
SP1,5/0,14-0,5	28, 36
SP1,5/0,14-0,5 AU	28, 34, 36
SP2/0,5-1,5	28, 40
SP2/0,5-1,5 AU	28, 40
SP2/2,5	40
SP2/2,5 AU	40
SP3/2,5-4	40
SP3/2,5-4 AU	40
SP3/2,5-4(K)	36, 40
SP3/2,5-4(K) AU	36, 40
SP5/6	38, 42
SP5/6 AU	38, 42
SP5/10	38, 42

Type	Page
SP5/10 AU	38, 42
SP6/6	42
SP6/6 AU	42
SP6/10	42
SP6/10 AU	42
SP6/16	42
SP6/16 AU	42
SP6/25	42
SP6/25 AU	42
SP8/25	44
SP8/35	44
SP11/25	38, 44
SP11/35-38	38, 44
SP11/50	38, 44
SP-C1,6/0,5-1,5 AU	46
SP-C3/2,5-4 AU	46
SP-C3/4-6 AU	46
SP-C6/10 AU	46
SP-C6/16 AU	46
SP-C6/25 AU	46
SP-R10/35 AU	46
SP-R10/50 AU	46
SP-R10/70 AU	46

Sorted by Order No.

Order No.	Page
18.8002	28, 36
18.8003	28, 34, 36
18.8004	28, 34, 36
18.8005	28, 34, 36
18.8024	28, 36
18.8025	28, 34, 36
18.8008	28, 40
18.8009	28, 40
18.8010	40
18.8011	40
18.8014	40
18.8015	40
18.8012	36, 40
18.8013	36, 40
18.8016	38, 42
18.8030	38, 42
18.8017	38, 42
18.8031	38, 42
18.8029	42
18.8032	42
18.8018	42
18.8033	42
18.8019	42
18.8034	42
18.8020	42
18.8035	42
18.8050	44
18.8051	44
18.8055	38, 44
18.8021	38, 44
18.8056	38, 44
19.6741	46
19.6743	46
19.6745	46
19.6747	46
19.6749	46
19.6751	46
19.6753	46
19.6755	46
19.6757	46
19.9108	46
19.9110	46
18.3112	87
18.3111	87

Order No.	Page
18.8061	32
18.8062	32
19.6718	32
18.8063	32
19.6726	32
19.6720	32
19.6722	32
19.6724	32
18.9061	32
18.9062	32
19.6717	32
18.9063	32
19.6725	32
19.6719	32
19.6721	32
19.6723	32
18.5674	89
18.5675	89
18.5652	89
18.5632	89
18.5633	89
18.5617	89
18.5618	89
18.4303	52, 53
18.4203	52, 53
18.4300	54
18.4200	54
18.4301	51, 52, 54
18.4304	52
18.4201	51, 52, 54
18.4204	52
18.4302	51, 52
18.4202	51, 52
19.6626	59
19.6627	59
18.4503	53
18.4712	57
18.4403	53
18.4612	57
19.6632	59
19.6633	59
18.4500	54
18.4713	57
18.4400	54

Order No.	Page
18.4613	57
18.4501	51, 52, 54
18.4714	57
18.4401	51, 52, 54
18.4614	57
19.6634	59
19.6635	59
18.4700	54, 55
18.4750	54, 55
18.4600	54, 55
18.4650	54, 55
19.6636	59
19.6637	59
19.9106	59
19.9109	59
18.4701	54, 55
18.4601	54, 55
18.4702	54, 55
18.4709	57
18.4602	54, 55
18.4609	57
19.6644	59
19.6645	59
18.4703	54
19.6648	59
19.6649	59
18.4603	54
18.4704	51, 52
18.4604	51, 52
18.4705	51, 52
18.4605	51, 52
18.4706	51, 52, 54
18.4708	56
18.4707	57
18.4606	51, 52, 54
18.4608	56
18.4607	57
19.6646	59
19.6647	59
18.4901	53
18.4801	53
18.4902	55
18.4802	55
18.4900	51, 52
18.4800	51, 52
18.5896	88

Order No.	Page
15.5377	88
15.5378	88
15.5373	88
18.3037	86
18.3036	86
18.3038	86
18.3001	86
18.3004	86
18.3019	86
18.3008	86
18.3011	86
18.3014	86
18.3017	86
18.3800	87
18.1312	64
18.1201	67
18.1301	67
18.1212	64
18.1200	67
18.1300	67
18.1205	63
18.1305	63
18.1203	63, 67
18.1303	63, 67
18.1314	63
18.1315	63
18.1204	63
18.1304	63
18.1202	63, 67
18.1302	63, 67
18.1214	63
18.1215	63
18.1207	63
18.1307	63
18.1206	63
18.1306	63
19.6660	73
19.6658	73
19.6654	73
19.6661	73
19.6659	73
19.6655	73
18.1509	71
18.1508	71
18.1411	64
19.6656	73

Order No.	Page
19.6652	73
18.1410	64
19.6657	73
19.6653	73
18.1401	67
18.1501	67
18.1400	67
18.1500	67
18.1403	67
18.1503	67
18.1511	71
18.1402	67
18.1502	67
18.1510	71
18.1407	63
18.1507	63
18.1405	63, 67
18.1505	63, 67
18.1513	71
18.1406	63
18.1506	63
18.1404	63, 67
18.1504	63, 67
18.1512	71
19.6650	73
19.6651	73
18.1605	69
18.1603	69
18.1601	69
18.1751	69
18.1753	69
18.1604	69
18.1602	69
18.1600	69
18.1750	69
18.1752	69
19.6670	73
19.6666	73
19.6672	73
19.6671	73
19.6667	73
19.6673	73
19.9107	73
19.9111	73
18.1609	69
18.1607	69

Order No.	Page
18.1608	69
18.1606	69
18.1613	69
18.1611	69
18.1711	71
18.1612	69
18.1610	69
18.1710	71
19.6668	73
19.6664	73
19.6669	73
19.6665	73
18.1615	67
18.1701	67
19.6674	73
19.6676	73
18.1614	67
18.1700	67
19.6675	73
19.6677	73
18.1617	63
18.1703	63
18.1616	63
18.1702	63
18.1619	63
18.1705	63
18.1618	63
18.1704	63
18.1623	63
18.1709	63
18.1625	70
18.1707	71
18.1622	63
18.1708	63
18.1624	70
18.1706	71
19.6662	73
19.6663	73
18.1817	64, 69
18.1813	64, 69
18.1816	64, 69
18.1812	64, 69
18.1801	63
18.1901	63
18.1800	63
18.1900	63

Order No.	Page
18.3039	86
18.3801	87
18.3802	87
18.3701	87
18.3702	87
18.3703	87
18.3704	87
18.3705	87
18.3000	86
18.3003	86
18.3010	86
18.3013	86
18.3016	86
18.3021	86
18.0242	84
18.0241	84
18.0240	84
18.0247	84
18.0245	84
18.0243	84
18.0248	84
18.0246	84
18.0244	84
18.0362	85
18.0360	85
18.0361	85
18.0367	85
18.0363	85
18.0365	85
18.0368	85
18.0364	85
18.0366	85
18.0101	77
18.0111	77
18.0100	77
18.0110	77
18.0201	77
18.0211	77
18.0200	77
18.0210	77
18.0303	77
18.0301	77
18.0309	77
18.0308	77
18.0305	79
18.0302	77

Order No.	Page
18.0300	77
18.0311	77
18.0310	77
18.0304	79
18.0415	77
18.0414	77
18.0117	83
18.0137	81
18.0133	81
18.0134	81
18.0135	81
18.0121	81
18.0107	83
18.0123	81
18.0116	83
18.0136	81
18.0130	81
18.0131	81
18.0132	81
18.0120	81
18.0106	83
18.0122	81
18.0231	81
18.0232	81
18.0221	81
18.0229	81
18.0230	81
18.0220	81
18.0350	82
18.0351	82
18.0352	82
18.0353	82
18.0354	82
18.0355	82
18.3700	87
18.3002	86
18.3005	86
18.3020	86
18.3009	86
18.3012	86
18.3015	86
18.3018	86
18.3022	86
18.3029	87
18.3025	87
18.5506	88

Order No.	Page
18.5500	88
18.5501	88
18.5502	88
18.5503	88
18.5505	88
18.9002	28, 36
18.9003	28, 34, 36
18.9004	28, 34, 36
18.9005	28, 34, 36
18.9024	28, 36
18.9025	28, 34, 36
18.9008	28, 40
18.9009	28, 40
18.9010	40
18.9011	40
18.9014	40
18.9015	40
18.9012	36, 40
18.9013	36, 40
18.9016	38, 42
18.9030	38, 42
18.9017	38, 42
18.9031	38, 42
18.9029	42

Order No.	Page
18.9032	42
18.9018	42
18.9033	42
18.9019	42
18.9034	42
18.9020	42
18.9035	42
18.9050	44
18.9051	44
18.9055	38, 44
18.9021	38, 44
18.9056	38, 44
19.6742	46
19.6744	46
19.6759	46
19.6748	46
19.6750	46
19.6752	46
19.6754	46
19.6756	46
19.6758	46



● Stäubli Units ○ Representatives/Agents

Global presence of the Stäubli Group

www.staubli.com