

HOUSING UPPER PART

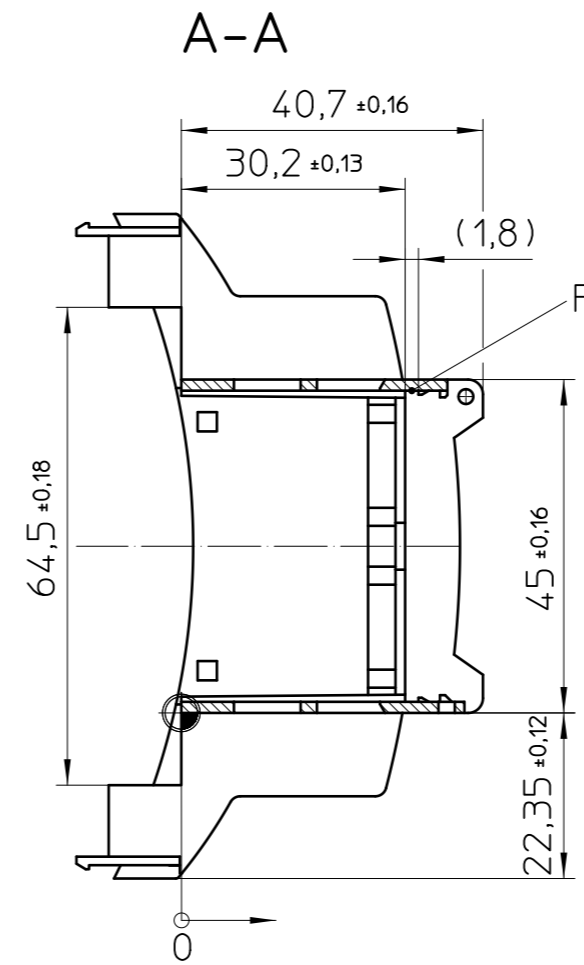

Assembly example

Overall dimensions compliant DIN 43880

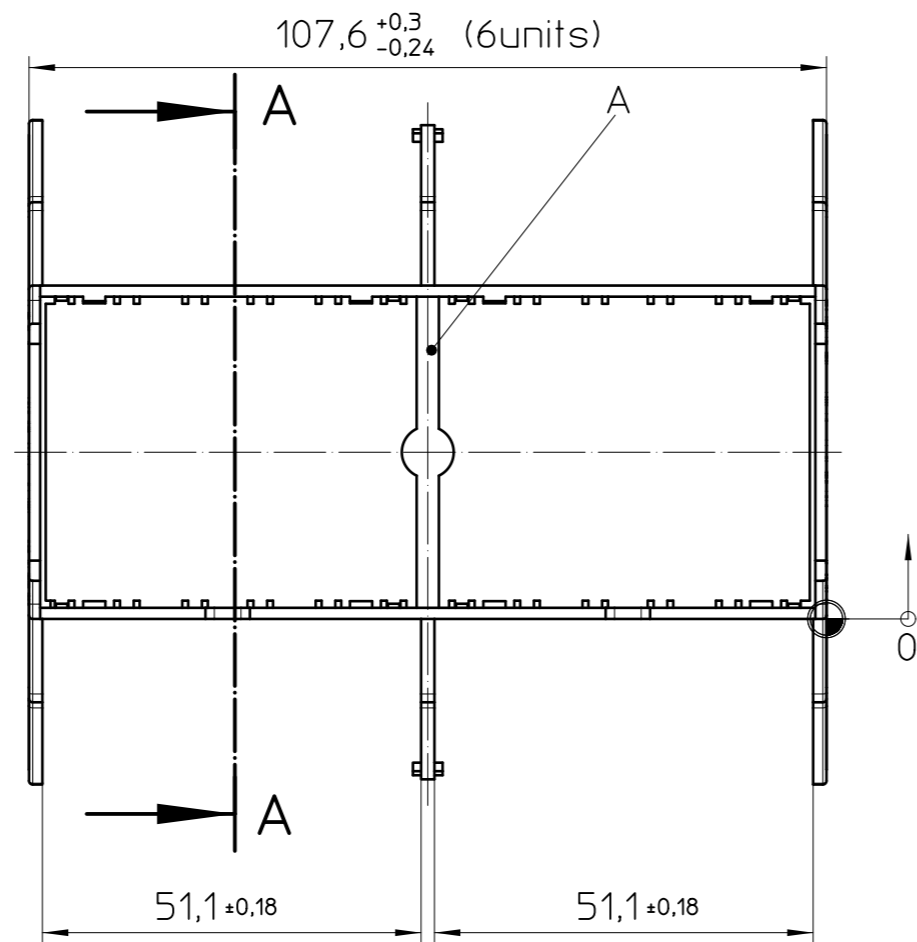
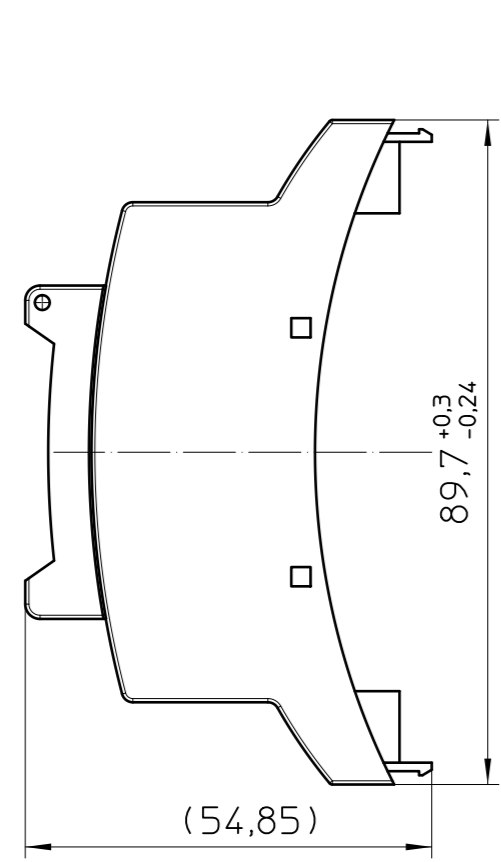
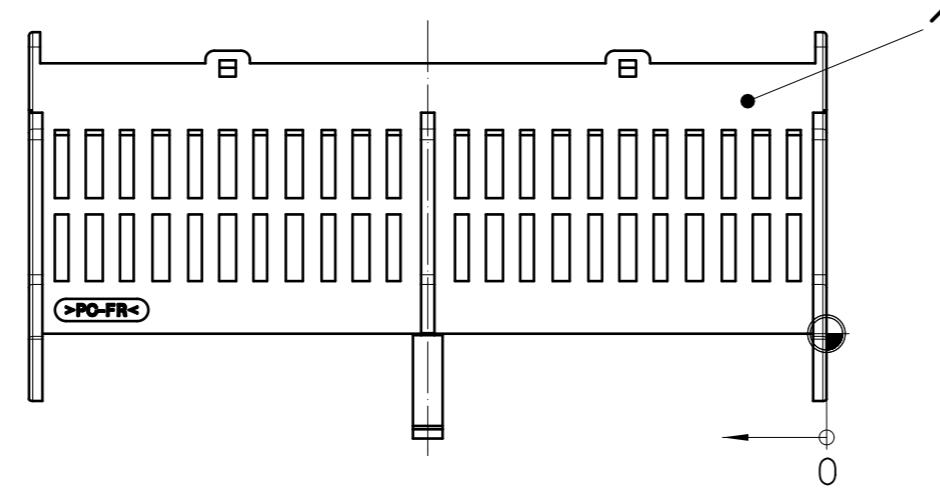
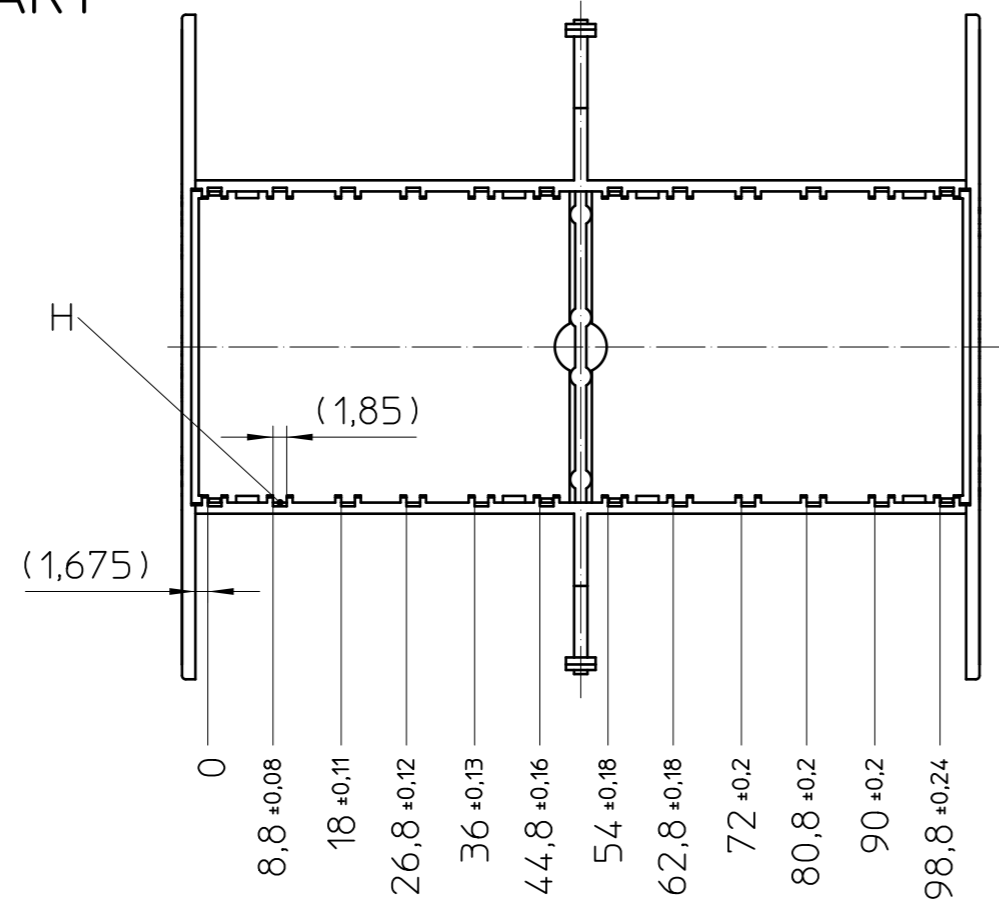
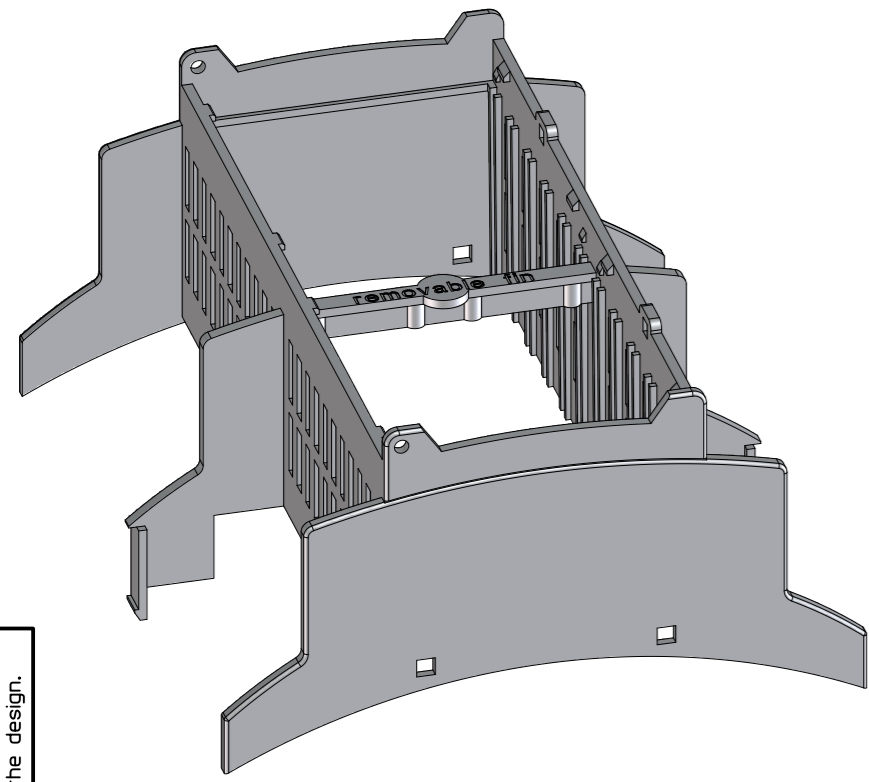
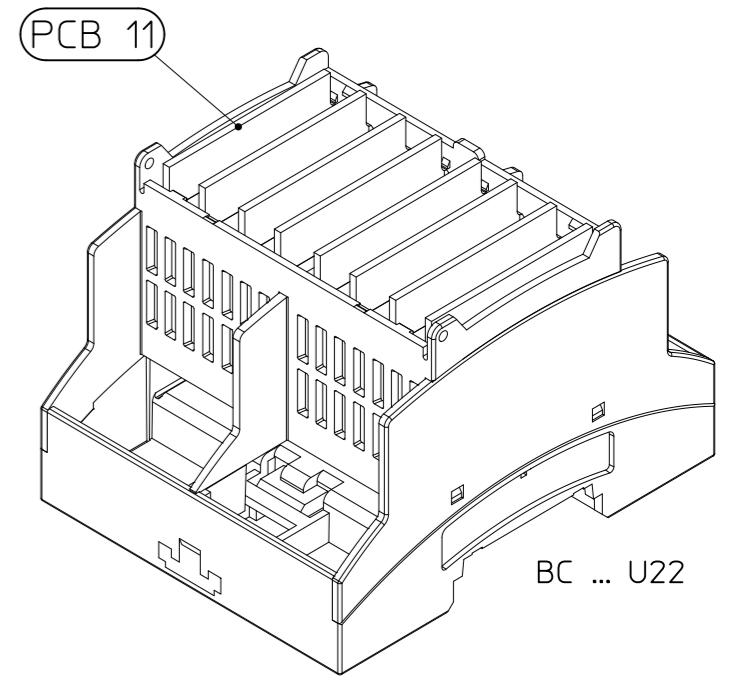
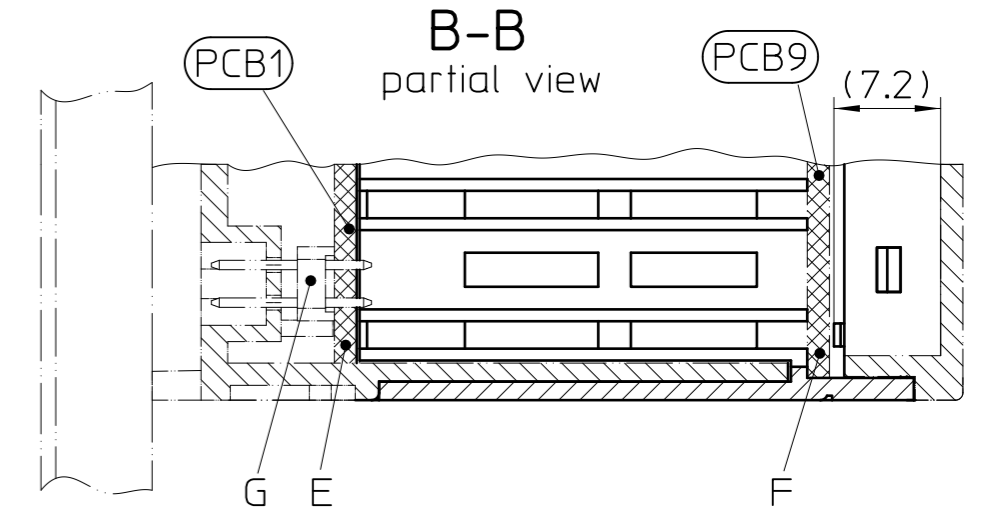
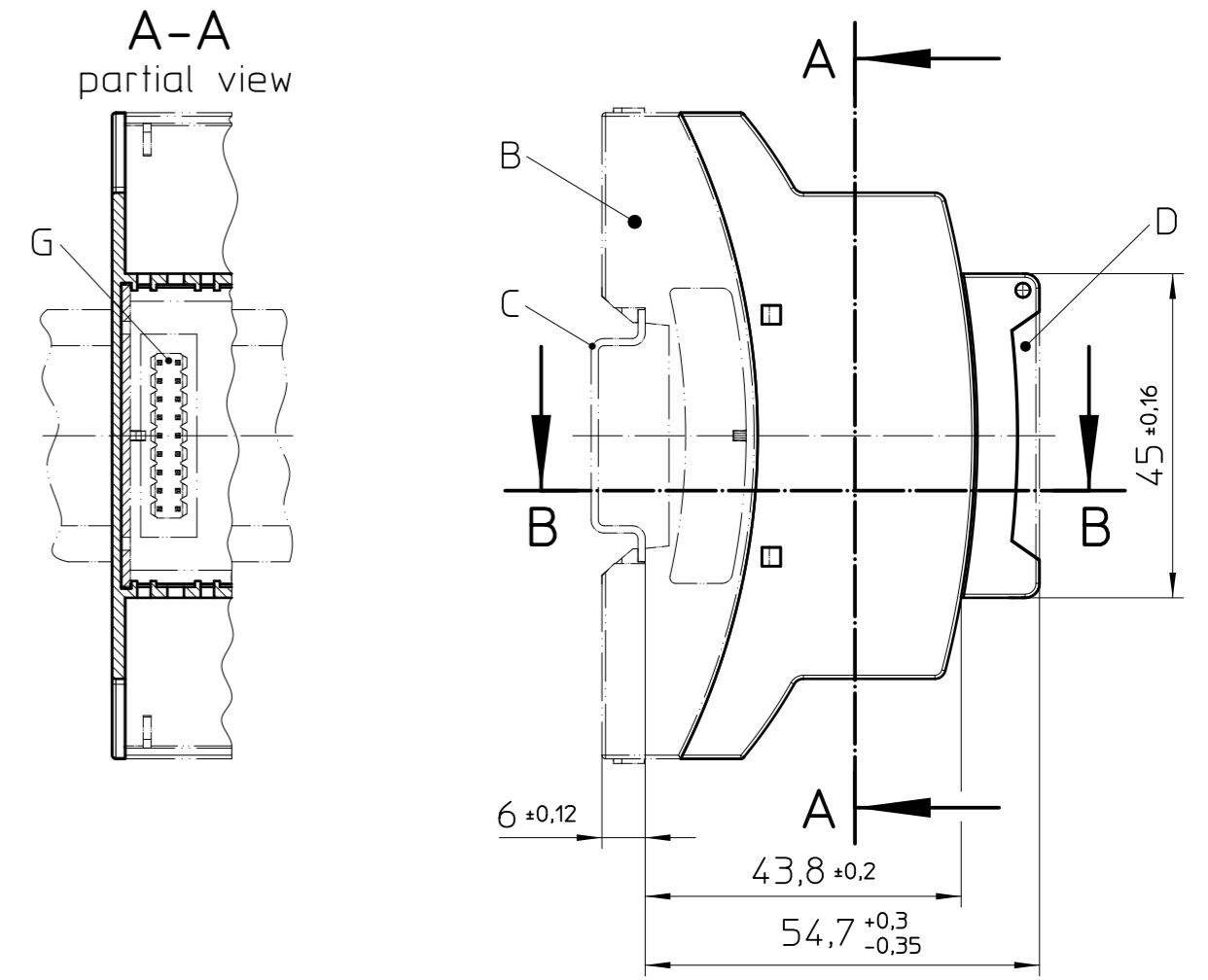

General Information:

- Simplified representation, exemplary shown in gray.
- Tolerances apply in a normal climate according to DIN EN ISO 291-23/50-2
- Workpiece zero point for mechanical processing
- Tolerances for mechanical processing are ISO 2768-mk
- Tolerances for printing DIN ISO 2768-m
- Machining radii min. R1, further on request
- Web: www.phoenixcontact.com

Additional information:

- A. If PCB 7+8 used, the fin has to be removed
- B. Housing lower part
- C. Mounting rail like EN 60715: TH 35-7,5 or mounting rail TH 35-15x1,5 similar to EN 60715
- D. Cover
- E. PCB 1 (main PCB)
- F. Position PCB 9 or position plate
- G. Header for HBUS (PSTD 0,65X0,65/9-2,54)
- H. PCB guidance for vertical PCB 11

Pos.	QTY	Description	Material
1	1	HOUSING UPPER PART	PC

	document-no. / ri	article-no.	scale	- Simplified representation - Document excluded from change process - Linear dimensions [mm]
	00907573 / 03	2896089	1:1	
	date	document-type		
	04.02.2025	TECDOC 2D_Productdrawing		
page 1	of 2	description		
		BC 107,6 OT U22 KMGY		

Transfer or duplication of this document as well as the utilisation or communication of its content are not permitted unless express consent is granted. Violations give rise to claims for damages. All rights reserved in case of patent, utility model or design patent registrations. Tolerance specifications do not include clearances inherent in the design.

Weitergabe sowie Vervielfältigung dieses Dokuments, Verwertung und Mitteilung seines Inhalts sind verboten, soweit nicht ausdrücklich gestattet. Zuwiderhandlungen verpflichten zu Schadenersatz. Alle Rechte für den Fall der Patent-, Gebrauchsmuster- oder Designeintragung vorbehalten. Bauabbedingtes Spiel ist in den Toleranzangaben nicht berücksichtigt.

Weitergabe sowie Vervielfältigung dieses Dokuments, Verwertung und Mitteilung seines Inhalts sind verboten, soweit nicht ausdrücklich gestattet. Zuwiderhandlungen verpflichten zu Schadenersatz. Alle Rechte für den Fall der Patent-, Gebrauchsmuster- oder Designeintragung vorbehalten. Bauartbedingtes Spiel ist in den Toleranzangaben nicht berücksichtigt.

Transfer or duplication of this document as well as the utilisation or communication of its content are not permitted unless express consent is granted. Violations give rise to claims for damages. All rights reserved in case of patent, utility model or design patent registrations. Tolerance specifications do not include clearances inherent in the design.

Marking area

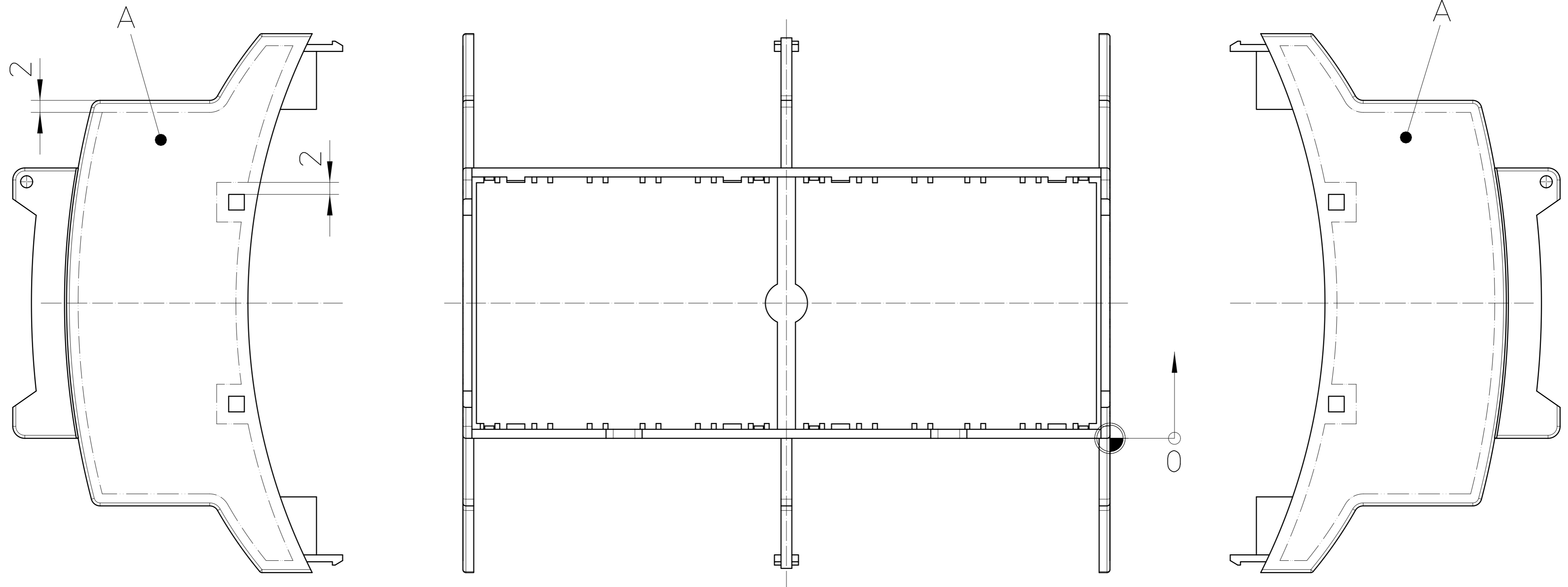



General Information:

- Tolerances apply in a normal climate according to DIN EN ISO 291-23/50-2
-  Workpiece zero point for mechanical processing
- Tolerances for mechanical processing are ISO 2768-mK
- Tolerances for printing DIN ISO 2768-m
- Machining radii min. R1, further on request
- Web: www.phoenixcontact.com

Additional information:

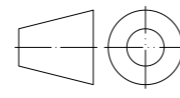
- A. Max. marking area left and right for pad printing and laser printing
- The marking area has 2mm distance from all contours of this face

 DIN A4	document-no. / ri	article-no.	scale	- Simplified representation - Document excluded from change process - Linear dimensions [mm]
	00907573 / 03	2896089	1:1	
	date	document-type		
	04.02.2025	TECDOC 2D_Productdrawing		
	description			
	BC 107,6 OT U22 KMGY			
page 2	of 2			