



reversing contactor assembly, AC-3e/AC-3, 25 A, 11 kW / 400 V, 3-pole, 230 V AC, 50/60 Hz, screw terminal, electrical and mechanical interlock, auxiliary contacts: 2 x 1 NO

product brand name	SIRIUS
product designation	Reversing contactor assembly
product type designation	3RA23
manufacturer's article number	
<ul style="list-style-type: none"> • 1 of the supplied contactor • 2 of the supplied contactor • of the supplied RH assembly kit 	3RT2026-1AL20 3RT2026-1AL20 3RA2923-2AA1
General technical data	
size of contactor	S0
product extension auxiliary switch	Yes
shock resistance at rectangular impulse	
<ul style="list-style-type: none"> • at AC • at DC 	8,3g / 5 ms, 5,3g / 10 ms 10g / 5 ms, 7,5g / 10 ms
shock resistance with sine pulse	
<ul style="list-style-type: none"> • at AC • at DC 	13,5g / 5 ms, 8,3g / 10 ms 15g / 5 ms, 10g / 10 ms
mechanical service life (operating cycles)	
<ul style="list-style-type: none"> • of contactor typical • of the contactor with added auxiliary switch block typical 	10 000 000 10 000 000
reference code according to IEC 81346-2	Q
Substance Prohibition (Date)	10/01/2009
Weight	0.92 kg
Ambient conditions	
installation altitude at height above sea level maximum	2 000 m
ambient temperature	
<ul style="list-style-type: none"> • during operation • during storage 	-25 ... +60 °C -55 ... +80 °C
Main circuit	
number of poles for main current circuit	3
number of NO contacts for main contacts	3
number of NC contacts for main contacts	0
operating voltage	
<ul style="list-style-type: none"> • at AC-3 rated value maximum • at AC-3e rated value maximum 	690 V 690 V
operational current	
<ul style="list-style-type: none"> • at AC-3 <ul style="list-style-type: none"> — at 400 V rated value — at 500 V rated value — at 690 V rated value • at AC-3e 	25 A 18 A 13 A

— at 400 V rated value	25 A
— at 500 V rated value	18 A
— at 690 V rated value	13 A
operating power	
● at AC-3	
— at 400 V rated value	11 kW
— at 500 V rated value	11 kW
— at 690 V rated value	11 kW
● at AC-3e	
— at 400 V rated value	11 kW
— at 690 V rated value	11 kW
● at AC-4 at 400 V rated value	7.5 kW
operating frequency	
● at AC-3 maximum	750 1/h
● at AC-3e maximum	750 1/h

Control circuit/ Control

type of voltage of the control supply voltage	AC
control supply voltage 1 at AC	
● at 50 Hz rated value	230 V
● at 60 Hz rated value	230 V
operating range factor control supply voltage rated value of magnet coil at AC	
● at 50 Hz	0.8 ... 1.1
● at 60 Hz	0.8 ... 1.1
apparent pick-up power of magnet coil at AC	
● at 50 Hz	77 VA
inductive power factor with closing power of the coil	
● at 50 Hz	0.82
apparent holding power of magnet coil at AC	
● at 50 Hz	9.8 VA
inductive power factor with the holding power of the coil	
● at 50 Hz	0.27

Auxiliary circuit

number of NO contacts for auxiliary contacts	
● per direction of rotation	1
● instantaneous contact	2
contact reliability of auxiliary contacts	< 1 error per 100 million operating cycles

UL/CSA ratings

full-load current (FLA) for 3-phase AC motor	
● at 480 V rated value	21 A
● at 600 V rated value	22 A
yielded mechanical performance [hp] for 3-phase AC motor	
● at 220/230 V rated value	7.5 hp
● at 460/480 V rated value	15 hp
● at 575/600 V rated value	20 hp
contact rating of auxiliary contacts according to UL	A600 / Q600

Short-circuit protection

design of the fuse link	
● for short-circuit protection of the main circuit	
— with type of coordination 1 required	gG NH 3NA, DIAZED 5SB, NEOZED 5SE: 100 A
— with type of coordination 2 required	gG NH 3NA, DIAZED 5SB, NEOZED 5SE: 35 A
● for short-circuit protection of the auxiliary switch required	fuse gG: 10 A

Installation/ mounting/ dimensions

mounting position	+/-180° rotation possible on vertical mounting surface; can be tilted forward and backward by +/- 22.5° on vertical mounting surface
fastening method	screw and snap-on mounting onto 35 mm DIN rail
height	101 mm
width	90 mm
depth	97 mm
required spacing	
● with side-by-side mounting	

— forwards	6 mm
— backwards	0 mm
— upwards	6 mm
— downwards	6 mm
— at the side	6 mm
• for grounded parts	
— forwards	6 mm
— backwards	0 mm
— upwards	6 mm
— at the side	6 mm
— downwards	6 mm
• for live parts	
— forwards	6 mm
— backwards	0 mm
— upwards	6 mm
— downwards	6 mm
— at the side	6 mm

Connections/ Terminals

type of electrical connection	
• for main current circuit	screw-type terminals
• for auxiliary and control circuit	screw-type terminals
• at contactor for auxiliary contacts	Screw-type terminals
• of magnet coil	Screw-type terminals
type of connectable conductor cross-sections for main contacts	
• solid	2x (1 ... 2.5 mm ²), 2x (2.5 ... 10 mm ²)
• solid or stranded	2x (1 ... 2.5 mm ²), 2x (2.5 ... 10 mm ²)
• finely stranded with core end processing	2x (1 ... 2.5 mm ²), 2x (2.5 ... 6 mm ²), 1x 10 mm ²
type of connectable conductor cross-sections	
• for auxiliary contacts	
— solid or stranded	2x (0.5 ... 1.5 mm ²), 2x (0.75 ... 2.5 mm ²)
— finely stranded with core end processing	2x (0.5 ... 1.5 mm ²), 2x (0.75 ... 2.5 mm ²)
• for AWG cables for auxiliary contacts	2x (20 ... 16), 2x (18 ... 14)





Safety related data

product function suitable for safety function	Yes
Electrical Safety	
protection class IP on the front according to IEC 60529	IP20
touch protection on the front according to IEC 60529	finger-safe, for vertical contact from the front







Communication/ Protocol

product function bus communication	Yes
protocol is supported AS-Interface protocol	No
product function control circuit interface with IO link	No

Approvals Certificates

General Product Approval	Test Certificates	Maritime application
 EG-Konf.		 UL
	Special Test Certificate	 ABS

Maritime application

 BUREAU VERITAS	 DNV	 LRS	 PRS	 RINA	 RMRS
---	--	--	--	---	---

other	Railway	Environment
-------	---------	-------------



[Confirmation](#)

[Special Test Certificate](#)

[Environmental Confirmations](#)

Further information

Information on the packaging

<https://support.industry.siemens.com/cs/ww/en/view/109813875>

Information for data generation and storage

<https://support.industry.siemens.com/cs/ww/en/view/109995012>

Information- and Downloadcenter (Catalogs, Brochures,...)

<https://www.siemens.com/ic10>

Industry Mall (Online ordering system)

<https://mall.industry.siemens.com/mall/en/en/Catalog/product?mlfb=3RA2326-8XB30-1AL2>

Cax online generator

<http://support.automation.siemens.com/WW/CAXorder/default.aspx?lang=en&mlfb=3RA2326-8XB30-1AL2>

Service&Support (Manuals, Certificates, Characteristics, FAQs,...)

<https://support.industry.siemens.com/cs/ww/en/ps/3RA2326-8XB30-1AL2>

Image database (product images, 2D dimension drawings, 3D models, device circuit diagrams, EPLAN macros, ...)

http://www.automation.siemens.com/bilddb/cax_de.aspx?mlfb=3RA2326-8XB30-1AL2&lang=en

Characteristic: Tripping characteristics, I²t, Let-through current

<https://support.industry.siemens.com/cs/ww/en/ps/3RA2326-8XB30-1AL2/char>

Further characteristics (e.g. electrical endurance, switching frequency)

<http://www.automation.siemens.com/bilddb/index.aspx?view=Search&mlfb=3RA2326-8XB30-1AL2&objecttype=14&gridview=view1>

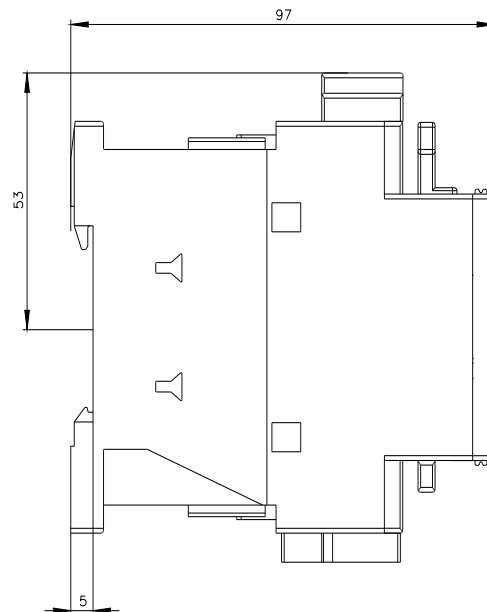
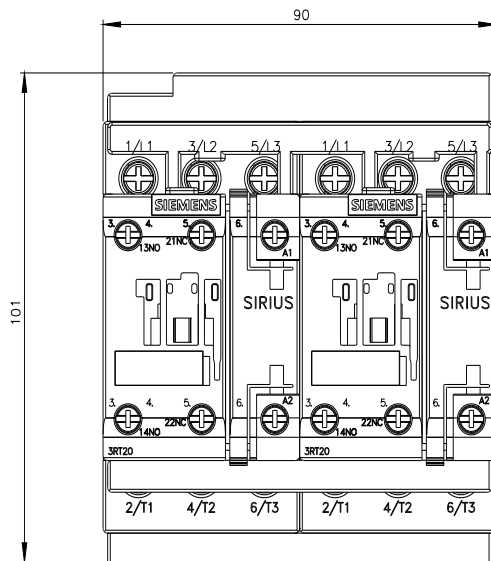

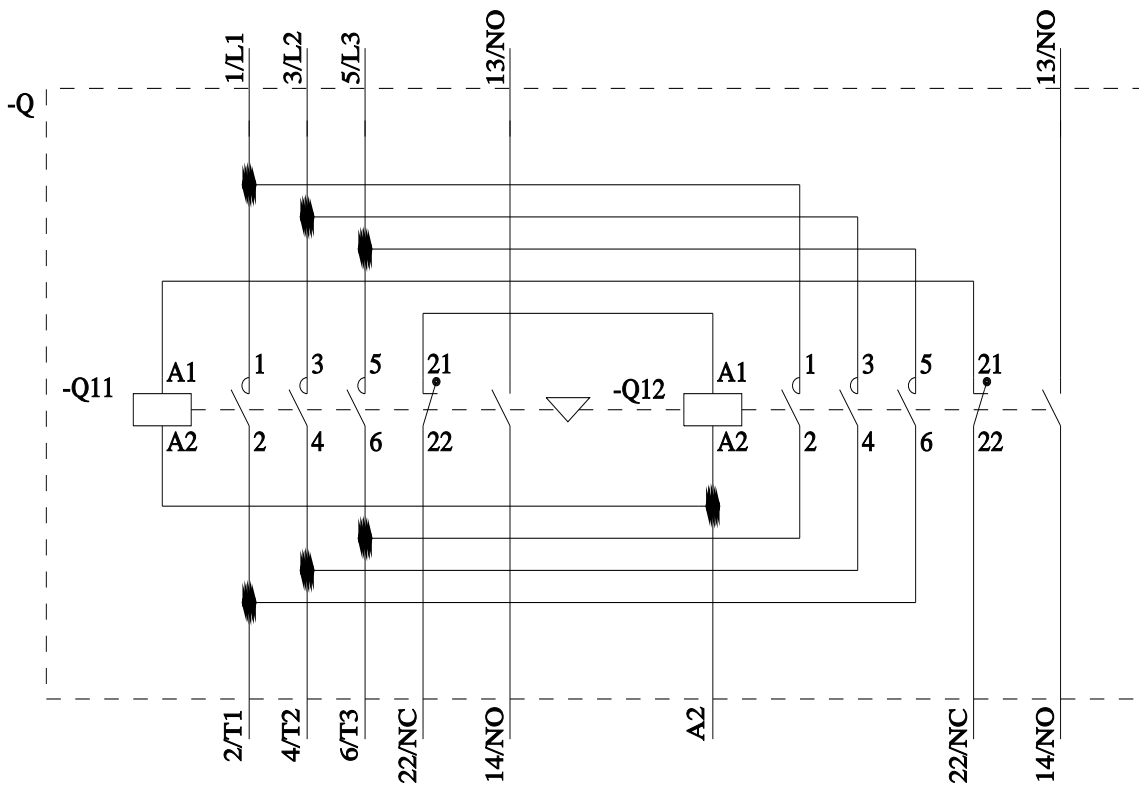

last modified:

8/8/2025