

Three-phase Phase-sequence Phase-loss Relay K8AB-PM

Ideal for monitoring 3-phase power supplies for industrial facilities and equipment.

- Monitor overvoltages, undervoltages, phase sequence, and phase loss for three-phase 3-wire or 4-wire power supplies with just one Unit.
Switch setting for 3-phase 3-wire or 3-phase 4-wire power supply.
- Two SPDT output relays, 6 A at 250 VAC (resistive load).
Output overvoltages and undervoltages using separate relays.
- World-wide power specifications supported by one Unit (switchable).
- Output status can be monitored using LED indicator.

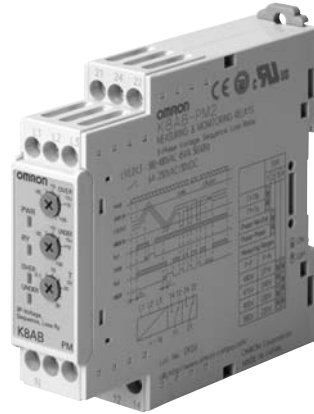

Model Number Structure

Model Number Legend

K8AB-□□

1 2 3

1. Basic Model

K8AB: Measuring and Monitoring Relays

2. Functions

PM: Three-phase Phase-sequence Phase-loss Relay (Simultaneous upper and lower monitoring)

3. Rated Input Voltage

- 1: 115, 127, 133, 138, 200, 220, 230, 240 VAC
- 2: 220, 230, 240, 277, 380, 400, 415, 480 VAC

Ordering Information

List of Models

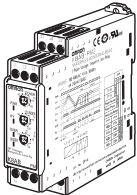
Three-phase Phase-sequence Phase-loss Relay	Rated input (See note 2.)		Model
	3-phase 3-wire mode	3-phase 4-wire mode	
	3-phase 3-wire mode	200, 220, 230, 240 VAC	K8AB-PM1
	3-phase 4-wire mode	115, 127, 133, 138 VAC	
	3-phase 3-wire mode	380, 400, 415, 480 VAC	K8AB-PM2
	3-phase 4-wire mode	220, 230, 240, 277 VAC	

- Note:**
1. Three-phase 3-wire or 4-wire and the input range are switched using a DIP switch.
 2. The power supply is shared with the rated input voltage.

Ratings and Specifications

■ Ratings

Rated input voltage	K8AB-PM1	Three-phase, three-wire Mode: 200, 220, 230 and 240 VAC Three-phase, four-wire Mode: 115, 127, 133 and 138 VAC
	K8AB-PM2	Three-phase, three-wire Mode: 380, 400, 415 and 480 VAC Three-phase, four-wire Mode: 220, 230, 240 and 277 VAC
Input load	K8AB-PM1: 25 VA max. K8AB-PM2: 45 VA max.	
Operating value setting range (OVER, UNDER)	Overvoltage -30% to 25% of rated input voltage Undervoltage -30% to 25% of rated input voltage Note: The rated input voltage can be switched using the DIP switch.	
Operating value	100% operation at set value	
Reset value	5% of operating value (fixed)	
Reset method	Automatic reset	
Operating time setting range (T)	Overvoltage/undervoltage	0.1 to 30 s
	Reversed phase/phase loss	0.1 s max.
Startup lock time (LOCK)	1 s or 5 s (Switched using DIP switch.)	
Indicators	Power (PWR): Green, Relay output (RY): Yellow, OVER/UNDER: Red	
Output relays	Two SPDT relays (NC operation)	
Output relay ratings	<p>Rated load</p> <p>Resistive load</p> <p>6 A at 250 VAC ($\cos\phi = 1$)</p> <p>6 A at 30 VDC (L/R = 0 ms)</p> <p>Inductive load</p> <p>1 A at 250 VAC ($\cos\phi = 0.4$)</p> <p>1 A at 30 VDC (L/R = 7 ms)</p> <p>Maximum contact voltage: 250 VAC</p> <p>Maximum contact current: 6 A AC</p> <p>Maximum switching capacity: 1,500 VA</p> <p>Minimum load: 10 mA at 5 VDC</p> <p>Mechanical life: 10,000,000 operations</p> <p>Electrical life: Make: 50,000 times, Break: 30,000 times</p>	
Ambient operating temperature	-20 to 60°C (with no condensation or icing)	
Storage temperature	-40 to 70°C (with no condensation or icing)	
Ambient operating humidity	25% to 85% (with no condensation)	
Storage humidity	25% to 85% (with no condensation)	
Altitude	2,000 m max.	
Terminal screw tightening torque	0.49 N·m	
Terminal wiring method	<p>Recommended wire</p> <p>Solid wire: 2.5 mm²</p> <p>Twisted wires: AWG16, AWG18</p> <p>Note: 1. Ferrules with insulating sleeves must be used with twisted wires. 2. Two wires can be twisted together.</p> <p>Recommended ferrules</p> <p>Al 1.5-8BK (for AWG16) manufactured by Phoenix Contact</p> <p>Al 1-8RD (for AWG18) manufactured by Phoenix Contact</p> <p>Al 0.75-8GY (for AWG18) manufactured by Phoenix Contact</p>	
Case color	Munsell 5Y8/1	
Case material	ABS resin (self-extinguishing resin) UL94-V0	
Weight	Approx. 130 g	
Mounting	Mounted to DIN Track or via M4 screws (tightening torque: 1.2 N·m)	
Dimensions	22.5 (W) × 90 (H) × 100 (D) mm	

■ Specifications

Input frequency range		45 to 65 Hz
Overload capacity		Continuous input: 115% of maximum input, 10 s max.: 125% of maximum input
Setting error	Operating value	Set value $\pm 10\%$ of full scale
	Operating time	
	Startup lock time	Set value ± 0.5 s
Repeat error	Operating value	Operating value $\pm 2\%$ Error calculation: Error = ((Maximum operating value – Minimum operating value (over 10 operations))/2)/Average value $\times 100\%$
	Reset value	Overvoltage: Operating value $\times 95\% \pm 2\%$ Undervoltage: Operating value $\times 105\% \pm 2\%$ Error calculation: Error = ((Maximum reset value – Minimum reset value (over 10 resets))/2)/Average value $\times 100\%$
	Operating time	Operating time repeat error: ± 50 ms Overvoltage: Measured when input suddenly changes from 70% to 120% of setting. Undervoltage: Measured when input suddenly changes from 120% to 70% of setting. The input voltage, however, must be between 70% and 125% of rating.
	Startup lock time	Startup lock time repeat error: ± 0.5 s (The operating time when the operating time is set to the minimum value and the power supply suddenly changes from 0% to 100%.)
Temperature influence		Operating value Drift based on measured value at standard temperature: –20°C to standard temperature: $\pm 1,000$ ppm/°C max. Standard temperature to 60°C: $\pm 1,000$ ppm/°C max. (Humidity: 25% to 80%) Operating time Fluctuation based on measured value at standard temperature: –20°C to standard temperature: $\pm 10\%$ max. Standard temperature to 60°C: $\pm 10\%$ max. (Humidity: 25% to 80%)
Humidity influence		Operating value Based on ambient humidity of 65% 25% to 80%: $\pm 5\%$ max. Operating time Based on ambient room humidity 25% to 80%: $\pm 10\%$ max.
Influence of input frequency		At 45 to 65 Hz Operating value $\pm 5\%$ max. Operating time $\pm 10\%$ max. Note: The error in the operating value and operating time under standard conditions.
Applicable standards	Conforming standards	EN60255-5 and EN60255-6 Installation environment (Pollution Degree 2, Overvoltage Category III)
	EMC	EN61326
	Safety standards	UL508
Insulation resistance		20 M Ω min. Between external terminals and case Between input terminals and output 1 terminals Between input terminals and output 2 terminals Between output 1 terminals and output 2 terminals
Dielectric strength		2,000 VAC for one minute Between external terminals and case Between input terminals and output 1 terminals Between input terminals and output 2 terminals Between output 1 terminals and output 2 terminals
Noise immunity		1,500 V power supply terminal common/normal mode Square-wave noise of ± 1 μ s/100 ns pulse width with 1-ns rise time
Vibration resistance		Frequency 10 to 55 Hz, 0.35-mm single amplitude, acceleration 50 m/s ² 10 sweeps of 5 min each in X, Y, and Z directions
Shock resistance		100 m/s ² , 3 times each in 6 directions along three axes (up/down, left/right, forward/backward)
Degree of protection		Terminal section: Finger protection

Connections

■ Wiring Diagram

Overvoltage/Undervoltage and Phase Sequence/Phase Loss Operation Diagram

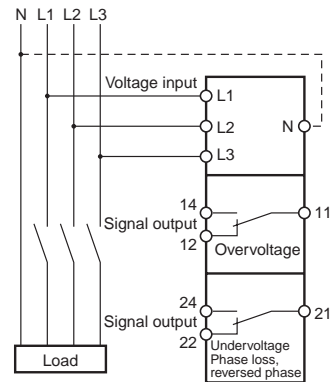
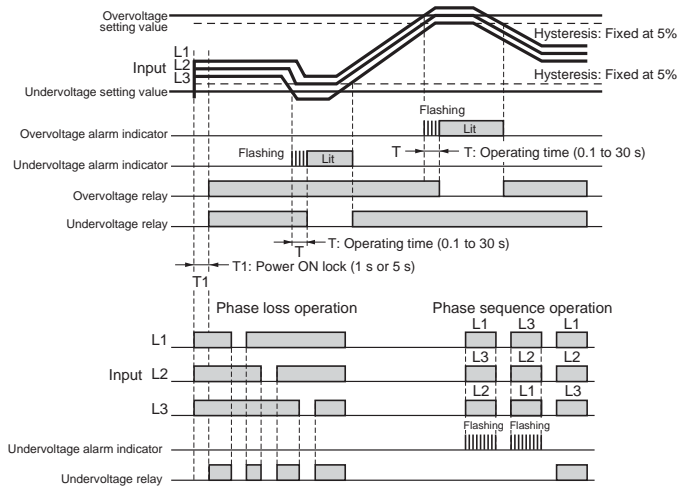

- Note:**
1. The K8AB-PM output relay is normally operative.
 2. The power ON lock prevents unnecessary alarms from being generated during the instable period when the power is first turned on. There is no relay output during timer operation.
 3. Phase loss is detected by L1, L2, and L3 voltage drops. A phase loss will exist if any of the phases drops below 60% of the rated input.
 4. L1 and L2 function both as the power supply terminals and as input terminals. If the voltage drops dramatically, then the Relay will not operate due to an undervoltage.
 5. Motor load phase loss cannot be detected during operation.
 6. Phase loss is detected based on voltage, so phase loss cannot be detected on the load side.

Nomenclature

Front

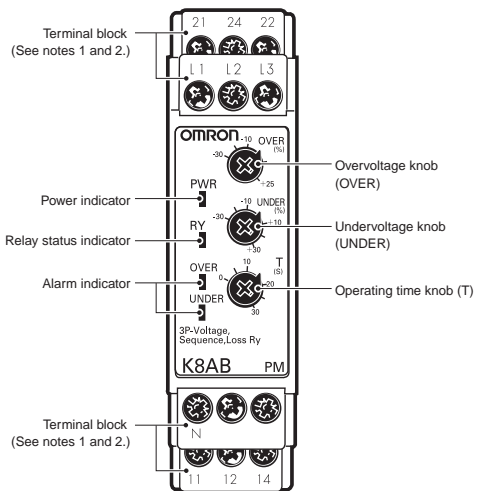

Indicators

Item	Meaning
Power indicator (PWR: Green)	Lit when power is being supplied (see note).
Relay status indicator (RY: Yellow)	Lit when relay is operating (normally lit).
Alarm indicator	Overvoltage: Red The indicator flashes to indicate the error status after the overvoltage has exceeded the threshold value while the operating time is being clocked.
	Undervoltage: Red <ul style="list-style-type: none"> Lit when there is an undervoltage or phase loss. The indicator flashes to indicate the error status after the undervoltage has exceeded the threshold value while the operating time is being clocked. Lit when there is a phase sequence error.

Note: The input across L1 and L2 is used for the internal power supply. Therefore, the power indicator will not be lit if there is no input across L1 and L2.

Setting Knobs

Item	Usage
Overvoltage knob (OVER)	Can be set between -30% and 25% of the rated input.
Undervoltage knob (UNDER)	Can be set between -30% and 25% of the rated input.
Operating time knob (T)	Used to set the operating time to 0.1 to 30 s.

Note: 1. Use either a solid wire of 2.5 mm² maximum or a ferrule with insulating sleeve for the terminal connection. The length of the exposed current-carrying part inserted into the terminal must be 8 mm or less to maintain dielectric strength after connection.



Recommended ferrules
Phoenix Contact

- AI 1,5-8BK (for AWG16)
- AI 1-8RD (for AWG18)
- AI 0,75-8GY (for AWG18)

- 2.** Tightening torque
Recommended: 0.49 N·m
Maximum: 0.54 N·m

■ Operation and Setting Methods

Connections

1. Input

Connect to L1, L2, and L3 (for three-phase three-wire mode) or L1, L2, L3, and N (for three-phase four-wire mode), depending on the mode selected using pin 2 on the DIP switch.

The Unit will not operate correctly if the DIP switch setting and the wiring do not agree.

Make sure the phase sequence is wired correctly. The Unit will not operate normally if the phase sequence is incorrect.

2. Outputs

Terminals 11, 12, and 14 are the output terminals for overvoltage (SPDT).

Terminals 21, 22, and 24 are the output terminals for undervoltage, phase loss, and reversed phase (SPDT).

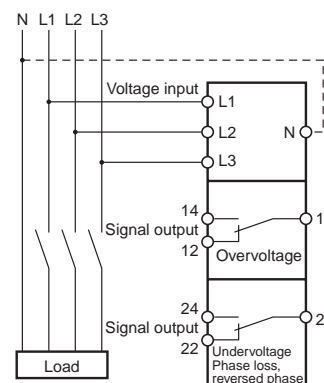

DIP Switch Settings

The power ON lock time, number of wires, and rated voltage are set using the DIP switch located on the bottom of the Unit.

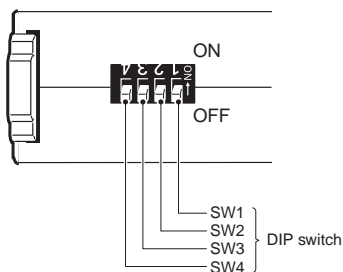

DIP Switch Functions

K8AB-PM1

SWITCH		ON ● ↑				
		4	3	2	1	
Power ON lock time	5 s	---	---	---	●	
	1 s	---	---	---	○	
Number of wires	Three-phase, four-wire	---	---	●	---	
	Three-phase, three-wire	---	---	○	---	
Rated voltage	Three-phase, three-wire					
	240 V	138 V	●	●	---	---
	230 V	133 V	●	○	---	---
	220 V	127 V	○	●	---	---
	200 V	115 V	○	○	---	---

Note: All pins are set to OFF at the factory.

K8AB-PM2

SWITCH		ON ● ↑				
		4	3	2	1	
Power ON lock time	5 s	---	---	---	●	
	1 s	---	---	---	○	
Number of wires	Three-phase, four-wire	---	---	●	---	
	Three-phase, three-wire	---	---	○	---	
Rated voltage	Three-phase, three-wire					
	480 V	277 V	●	●	---	---
	415 V	240 V	●	○	---	---
	400 V	230 V	○	●	---	---
	380 V	220 V	○	○	---	---

Note: All pins are set to OFF at the factory.

Setting Method

1. Overvoltage

The overvoltage knob (OVER) is used to set the overvoltage threshold.

The overvoltage can be set to between -30% and 25% of the rated input voltage.

Turn the knob while there is an input to the input terminals until the alarm indicator flashes (when the set value and the input have reached the same level.)

Use this as a guide to set the voltage.

The rated input depends on the model and DIP switch setting.

Example: K8AB-PM1 with Pin 2 Turned OFF (Three-phase, Three-wire Mode) and Pins 3 and 4 Turned OFF (Rated Voltage of 200 V)

The rated input voltage is 200 VAC and the setting range is 140 to 250 V.

2. Undervoltage

Undervoltage is set using the undervoltage knob (UNDER).

The undervoltage can be set to between -30% and 25% of the rated input.

Turn the knob while there is an input to the input terminals until the alarm indicator flashes (when the set value and the input have reached the same level.)

Use this as a guide to set the voltage.

The rated input depends on the model and DIP switch setting.

Example: K8AB-PM1 with Pin 2 Turned OFF (Three-phase, Three-wire Mode) and Pins 3 and 4 Turned OFF (Rated Voltage of 200 V)

The rated input voltage is 200 VAC and the setting range is 140 to 250 V.

3. Operating Time

The operating time is set using the operating time knob (T).

The operating time can be set to between 0.1 and 30 s.

Turn the knob while there is an input to the input terminals until the alarm indicator flashes (when the set value and the input have reached the same level.)

Use this as a guide to set the operating time.

If the input exceeds (or drops lower than) the voltage setting, the alarm indicator will start flashing for the set period and then stay lit.

Dimensions

(Unit: mm)

Three-phase Voltage with Phase-sequence, Phase-loss Relays

K8AB-PM1

K8AB-PM2

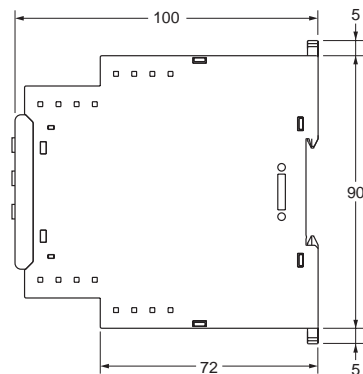
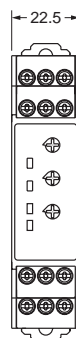
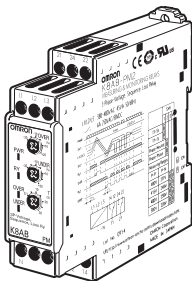

Safety Precautions

■ Precautions for Safe Use

Make sure to follow the instructions below to ensure safety.

1. Do not use or keep this product in the following environments.
 - Outdoors, or places subject to direct sunlight or wearing weather.
 - Places where dust, iron powder, or corrosive gases (in particular, sulfuric or ammonia gas) exist.
 - Places subject to static electricity or inductive noise.
 - Places where water or oil come in contact with the product.
2. Make sure to install this product in the correct direction.
3. There is a remote risk of electric shock. Do not touch terminals while electricity is being supplied.
4. Make sure to thoroughly understand all instructions in the Instructions Manual before handling this product.
5. Make sure to confirm terminal makings and polarity for correct wiring.
6. Tighten terminal screws firmly using the following torque.
Recommended tightening torque: 0.49 N·m
Maximum tightening torque: 0.54 N·m max.
7. Operating ambient temperature and humidity for this product must be within the indicated rating when using this product.
8. There is a remote risk of explosion. Do not use this product where flammable or explosive gas exists.
9. Make sure that no weight rests on the product after installation.
10. To enable an operator to turn off this product easily, install switches or circuit breakers that conform to relevant requirements of IEC60947-1 and IEC60947-3, and label them appropriately.

■ Precautions for Correct Use

For Proper Use

1. Do not use the product in the following locations.
 - Places subject to radiant heat from heat generating devices.
 - Places subject to vibrations or physical shocks.
2. Make sure to use setting values appropriate for the controlled object. Failure to do so can cause unintended operation, and may result in accident or corruption of the product.
3. Do not use thinner or similar solvent for cleaning. Use commercial alcohol.
4. When discarding, properly dispose of the product as industrial waste.
5. Only use this product within a board whose structure allows no possibility for fire to escape.

About Installation

1. When wiring, use only recommended crimp terminals.
2. Do not block areas around the product for proper dissipation of heat. (If you do not secure space for heat dissipation, life cycle of the product will be compromised.)
3. To avoid electrical shocks, make sure that power is not supplied to the product while wiring.
4. To avoid electrical shocks, make sure that power is not supplied to the product when performing DIP switch settings.

Noise Countermeasures

1. Do not install the product near devices generating strong high frequency waves or surges.
2. When using a noise filter, check the voltage and current and install it as close to the product as possible.
3. In order to prevent inductive noise, wire the lines connected to the product separately from power lines carrying high voltages or currents. Do not wire in parallel with or on the same cable as power lines.
Other measures for reducing noise include running lines along separate ducts and using shield lines.

To avoid faulty operations, malfunctions, or failure, observe the following operating instructions.

1. When turning on the power, make sure to realize rated voltage within 1 second from the time of first supply of electricity.
2. Make sure to use power supply for operations, inputs, and transformer with the appropriate capacity and rated burden.
3. Maintenance and handling of this product may only be performed by qualified personnel.
4. Distortion ratio of input wave forms must be 30% or less. Use of this product with circuits that have large distortion in wave forms may result in unwanted operations.
5. Using this product for thyristor controls or inverters will result in errors.
6. When setting the volume, adjust the control from the minimum side to the maximum side.

Questions and Answers

Q **Checking Operation**

A **Overvoltages**
 Gradually increase the input from 80% of the setting. The input value will equal the operating value when the input exceeds the setting and the alarm indicator starts flashing. Operation can be checked by the relay output that will start after the operating time has passed.
Undervoltage
 Gradually decrease the input from 120% of the setting and check the operation using the same method as for overvoltage.

Example: For monitoring mode set to three-phase three-wire monitoring, a rated voltage of 200 V, and an operating time of 5 s.

Note: K8AB-PM□ output relays are normally operative.

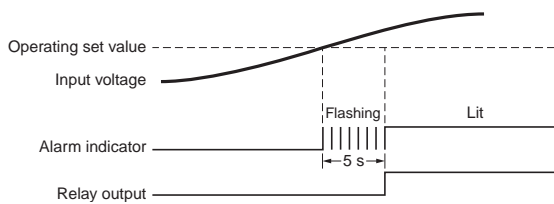

Connection Diagram 1

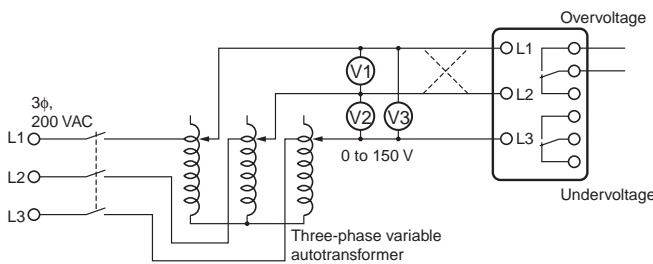

Q **How to Measure the Operating Time**

A **Overvoltage**
 Change the input suddenly from 0% to 120% of the set value and measure the time until the Unit operates.
Undervoltage
 Change the input suddenly from 120% to 0% of the set value and measure the time until the Unit operates.
Operating Time
 Adjust the slide resistor so that the voltage applied to the K8AB terminals is 120% of the set value (for overvoltage detection) and 80% of the set value (for undervoltage detection) when the auxiliary relay operates, as shown in connection diagram 2. Close the switch and use the cycle counter to measure the operating time.

Connection Diagram 2

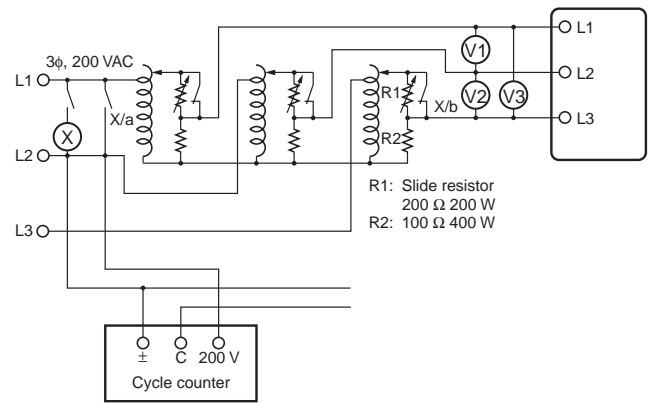

Q **Checking the Phase Sequence and Phase Loss Operation**

A **Phase Sequence**
 Switch the wiring, as shown by the dotted lines in connection diagram 1, to reverse the phase sequence and check that the K8AB operates.
Phase loss
 Create a phase loss for any input phase and check that the K8AB operates.

Q **Operating Adjustment Knobs**

A Use a screwdriver to turn the knobs. There is a stopper to prevent the knob from turning any further once it has been turned completely to the left or right. Do not force the knob past these limits.

Questions and Answers

Q Load-side Phase Loss

A In principle, phase loss cannot be detected on the load side because the K8AB-PM□ measures three-phase voltage to determine phase loss.

Q Motor Load Phase Loss during Operation

A Motor load phase loss cannot be detected during operation. It can be used to detect phase loss at startup.

Normally, three-phase motors will continue to rotate even if one phase is open. The three-phase voltage will be induced at the motor terminals. The diagram shows voltage induction at the motor terminals when phase R has been lost with a load applied to a three-phase motor. The horizontal axis shows the motor load as a percentage of the rated load, and the vertical axis shows voltage as a percentage of the rated voltage. The lines in the graph show the voltage induced at the motor terminals for each load phase loss occurs during operation. As the graph shows, phase loss cannot be detected because the motor terminal voltage does not drop very much even if a phase is lost when the load on the motor is light. To detect motor load phase loss during operation, use the undervoltage detection function to detect the motor terminal voltages at phase loss.

Set the operating time carefully because it will affect the time from when the phase loss occurs until tripping when this function is used.

Q Overvoltage Detection When Only One Phase Exceeds the Overvoltage Threshold

A The K8AB monitors each of the three-phase voltages. This means an overvoltage is detected if even only one phase exceeds the threshold value. The same applies to undervoltages.

Characteristic Curve Diagram

Note: This characteristic curve shows the approximate values only.

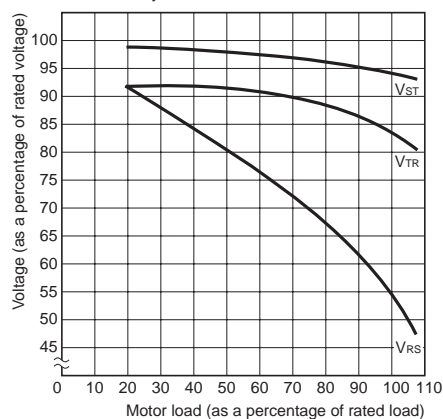

Note: For phase loss of phase R. V_{st}, V_{tr}, and V_{rs} indicate the motor terminal voltage at phase loss.

Terms and Conditions of Sale

1. **Offer; Acceptance.** These terms and conditions (these "Terms") are deemed part of all quotes, agreements, purchase orders, acknowledgments, price lists, catalogs, manuals, brochures and other documents, whether electronic or in writing, relating to the sale of products or services (collectively, the "Products") by Omron Electronics LLC and its subsidiary companies ("Omron"). Omron objects to any terms or conditions proposed in Buyer's purchase order or other documents which are inconsistent with, or in addition to, these Terms.
2. **Prices; Payment Terms.** All prices stated are current, subject to change without notice by Omron. Omron reserves the right to increase or decrease prices on any unshipped portions of outstanding orders. Payments for Products are due net 30 days unless otherwise stated in the invoice.
3. **Discounts.** Cash discounts, if any, will apply only on the net amount of invoices sent to Buyer after deducting transportation charges, taxes and duties, and will be allowed only if (i) the invoice is paid according to Omron's payment terms and (ii) Buyer has no past due amounts.
4. **Interest.** Omron, at its option, may charge Buyer 1-1/2% interest per month or the maximum legal rate, whichever is less, on any balance not paid within the stated terms.
5. **Orders.** Omron will accept no order less than \$200 net billing.
6. **Governmental Approvals.** Buyer shall be responsible for, and shall bear all costs involved in, obtaining any government approvals required for the importation or sale of the Products.
7. **Taxes.** All taxes, duties and other governmental charges (other than general real property and income taxes), including any interest or penalties thereon, imposed directly or indirectly on Omron or required to be collected directly or indirectly by Omron for the manufacture, production, sale, delivery, importation, consumption or use of the Products sold hereunder (including customs duties and sales, excise, use, turnover and license taxes) shall be charged to and remitted by Buyer to Omron.
8. **Financial.** If the financial position of Buyer at any time becomes unsatisfactory to Omron, Omron reserves the right to stop shipments or require satisfactory security or payment in advance. If Buyer fails to make payment or otherwise comply with these Terms or any related agreement, Omron may (without liability and in addition to other remedies) cancel any unshipped portion of Products sold hereunder and stop any Products in transit until Buyer pays all amounts, including amounts payable hereunder, whether or not then due, which are owing to it by Buyer. Buyer shall in any event remain liable for all unpaid accounts.
9. **Cancellation; Etc.** Orders are not subject to rescheduling or cancellation unless Buyer indemnifies Omron against all related costs or expenses.
10. **Force Majeure.** Omron shall not be liable for any delay or failure in delivery resulting from causes beyond its control, including earthquakes, fires, floods, strikes or other labor disputes, shortage of labor or materials, accidents to machinery, acts of sabotage, riots, delay in or lack of transportation or the requirements of any government authority.
11. **Shipping; Delivery.** Unless otherwise expressly agreed in writing by Omron:
 - a. Shipments shall be by a carrier selected by Omron; Omron will not drop ship except in "break down" situations.
 - b. Such carrier shall act as the agent of Buyer and delivery to such carrier shall constitute delivery to Buyer;
 - c. All sales and shipments of Products shall be FOB shipping point (unless otherwise stated in writing by Omron), at which point title and risk of loss shall pass from Omron to Buyer; provided that Omron shall retain a security interest in the Products until the full purchase price is paid;
 - d. Delivery and shipping dates are estimates only; and
 - e. Omron will package Products as it deems proper for protection against normal handling and extra charges apply to special conditions.
12. **Claims.** Any claim by Buyer against Omron for shortage or damage to the Products occurring before delivery to the carrier must be presented in writing to Omron within 30 days of receipt of shipment and include the original transportation bill signed by the carrier noting that the carrier received the Products from Omron in the condition claimed.
13. **Warranties.** (a) **Exclusive Warranty.** Omron's exclusive warranty is that the Products will be free from defects in materials and workmanship for a period of twelve months from the date of sale by Omron (or such other period expressed in writing by Omron). Omron disclaims all other warranties, express or implied. (b) **Limitations.** OMRON MAKES NO WARRANTY OR REPRESENTATION, EXPRESS OR IMPLIED, ABOUT NON-INFRINGEMENT, MERCHANTABILITY OR FITNESS FOR A PARTICULAR PURPOSE OF THE PRODUCTS. BUYER ACKNOWLEDGES THAT IT ALONE HAS DETERMINED THAT THE PRODUCTS WILL SUITABLY MEET THE REQUIREMENTS OF THEIR INTENDED USE. Omron further disclaims all warranties and responsibility of any type for claims or expenses based on infringement by the Products or otherwise of any intellectual property right. (c) **Buyer Remedy.** Omron's sole obligation hereunder shall be, at Omron's election, to (i) replace (in the form originally shipped with Buyer responsible for labor charges for removal or replacement thereof) the non-complying Product, (ii) repair the non-complying Product, or (iii) repay or credit Buyer an amount equal to the purchase price of the non-complying Product; provided that in no event shall Omron be responsible for warranty, repair, indemnity or any other claims or expenses regarding the Products unless Omron's analysis confirms that the Products were properly handled, stored, installed and maintained and not subject to contamination, abuse, misuse or inappropriate modification. Return of any Products by Buyer must be approved in writing by Omron before shipment. Omron Companies shall not be liable for the suitability or unsuitability or the results from the use of Products in combination with any electrical or electronic components, circuits, system assemblies or any other materials or substances or environments. Any advice, recommendations or information given orally or in writing, are not to be construed as an amendment or addition to the above warranty. See <http://oeweb.omron.com> or contact your Omron representative for published information.
14. **Limitation on Liability; Etc.** OMRON COMPANIES SHALL NOT BE LIABLE FOR SPECIAL, INDIRECT, INCIDENTAL, OR CONSEQUENTIAL DAMAGES, LOSS OF PROFITS OR PRODUCTION OR COMMERCIAL LOSS IN ANY WAY CONNECTED WITH THE PRODUCTS, WHETHER SUCH CLAIM IS BASED IN CONTRACT, WARRANTY, NEGLIGENCE OR STRICT LIABILITY. Further, in no event shall liability of Omron Companies exceed the individual price of the Product on which liability is asserted.
15. **Indemnities.** Buyer shall indemnify and hold harmless Omron Companies and their employees from and against all liabilities, losses, claims, costs and expenses (including attorney's fees and expenses) related to any claim, investigation, litigation or proceeding (whether or not Omron is a party) which arises or is alleged to arise from Buyer's acts or omissions under these Terms or in any way with respect to the Products. Without limiting the foregoing, Buyer (at its own expense) shall indemnify and hold harmless Omron and defend or settle any action brought against such Companies to the extent based on a claim that any Product made to Buyer specifications infringed intellectual property rights of another party.
16. **Property; Confidentiality.** Any intellectual property in the Products is the exclusive property of Omron Companies and Buyer shall not attempt to duplicate it in any way without the written permission of Omron. Notwithstanding any charges to Buyer for engineering or tooling, all engineering and tooling shall remain the exclusive property of Omron. All information and materials supplied by Omron to Buyer relating to the Products are confidential and proprietary, and Buyer shall limit distribution thereof to its trusted employees and strictly prevent disclosure to any third party.
17. **Export Controls.** Buyer shall comply with all applicable laws, regulations and licenses regarding (i) export of products or information; (ii) sale of products to "forbidden" or other proscribed persons; and (iii) disclosure to non-citizens of regulated technology or information.
18. **Miscellaneous.** (a) **Waiver.** No failure or delay by Omron in exercising any right and no course of dealing between Buyer and Omron shall operate as a waiver of rights by Omron. (b) **Assignment.** Buyer may not assign its rights hereunder without Omron's written consent. (c) **Law.** These Terms are governed by the law of the jurisdiction of the home office of the Omron company from which Buyer is purchasing the Products (without regard to conflict of law principles). (d) **Amendment.** These Terms constitute the entire agreement between Buyer and Omron relating to the Products, and no provision may be changed or waived unless in writing signed by the parties. (e) **Severability.** If any provision hereof is rendered ineffective or invalid, such provision shall not invalidate any other provision. (f) **Setoff.** Buyer shall have no right to set off any amounts against the amount owing in respect of this invoice. (g) **Definitions.** As used herein, "including" means "including without limitation"; and "Omron Companies" (or similar words) mean Omron Corporation and any direct or indirect subsidiary or affiliate thereof.

Certain Precautions on Specifications and Use

1. **Suitability of Use.** Omron Companies shall not be responsible for conformity with any standards, codes or regulations which apply to the combination of the Product in the Buyer's application or use of the Product. At Buyer's request, Omron will provide applicable third party certification documents identifying ratings and limitations of use which apply to the Product. This information by itself is not sufficient for a complete determination of the suitability of the Product in combination with the end product, machine, system, or other application or use. Buyer shall be solely responsible for determining appropriateness of the particular Product with respect to Buyer's application, product or system. Buyer shall take application responsibility in all cases but the following is a non-exhaustive list of applications for which particular attention must be given:
 - (i) Outdoor use, uses involving potential chemical contamination or electrical interference, or conditions or uses not described in this document.
 - (ii) Use in consumer products or any use in significant quantities.
 - (iii) Energy control systems, combustion systems, railroad systems, aviation systems, medical equipment, amusement machines, vehicles, safety equipment, and installations subject to separate industry or government regulations.
 - (iv) Systems, machines and equipment that could present a risk to life or property. Please know and observe all prohibitions of use applicable to this Product.
 NEVER USE THE PRODUCT FOR AN APPLICATION INVOLVING SERIOUS RISK TO LIFE OR PROPERTY OR IN LARGE QUANTITIES WITHOUT ENSURING THAT THE SYSTEM AS A WHOLE HAS BEEN DESIGNED TO ADDRESS THE RISKS, AND THAT THE OMRON'S PRODUCT IS PROPERLY RATED AND INSTALLED FOR THE INTENDED USE WITHIN THE OVERALL EQUIPMENT OR SYSTEM.
2. **Programmable Products.** Omron Companies shall not be responsible for the user's programming of a programmable Product, or any consequence thereof.
3. **Performance Data.** Data presented in Omron Company websites, catalogs and other materials is provided as a guide for the user in determining suitability and does not constitute a warranty. It may represent the result of Omron's test conditions, and the user must correlate it to actual application requirements. Actual performance is subject to the Omron's Warranty and Limitations of Liability.
4. **Change in Specifications.** Product specifications and accessories may be changed at any time based on improvements and other reasons. It is our practice to change part numbers when published ratings or features are changed, or when significant construction changes are made. However, some specifications of the Product may be changed without any notice. When in doubt, special part numbers may be assigned to fix or establish key specifications for your application. Please consult with your Omron's representative at any time to confirm actual specifications of purchased Product.
5. **Errors and Omissions.** Information presented by Omron Companies has been checked and is believed to be accurate; however, no responsibility is assumed for clerical, typographical or proofreading errors or omissions.

Complete "Terms and Conditions of Sale" for product purchase and use are on Omron's website at www.omron.com/oei – under the "About Us" tab, in the Legal Matters section.

ALL DIMENSIONS SHOWN ARE IN MILLIMETERS.

To convert millimeters into inches, multiply by 0.03937. To convert grams into ounces, multiply by 0.03527.

OMRON[®]**OMRON ELECTRONICS LLC**

One Commerce Drive
Schaumburg, IL 60173

847-843-7900

For US technical support or other inquiries:

800-556-6766**OMRON CANADA, INC.**

885 Milner Avenue
Toronto, Ontario M1B 5V8

416-286-6465**OMRON ON-LINE**

Global - <http://www.omron.com>
USA - <http://www.omron.com/oei>
Canada - <http://www.omron.ca>