

## X.FL Series

0.94mm or 1.2mm Mated Height

Low Profile, Lightweight and Compact SMT Coaxial Connectors



RF



Compact



Wide Variation

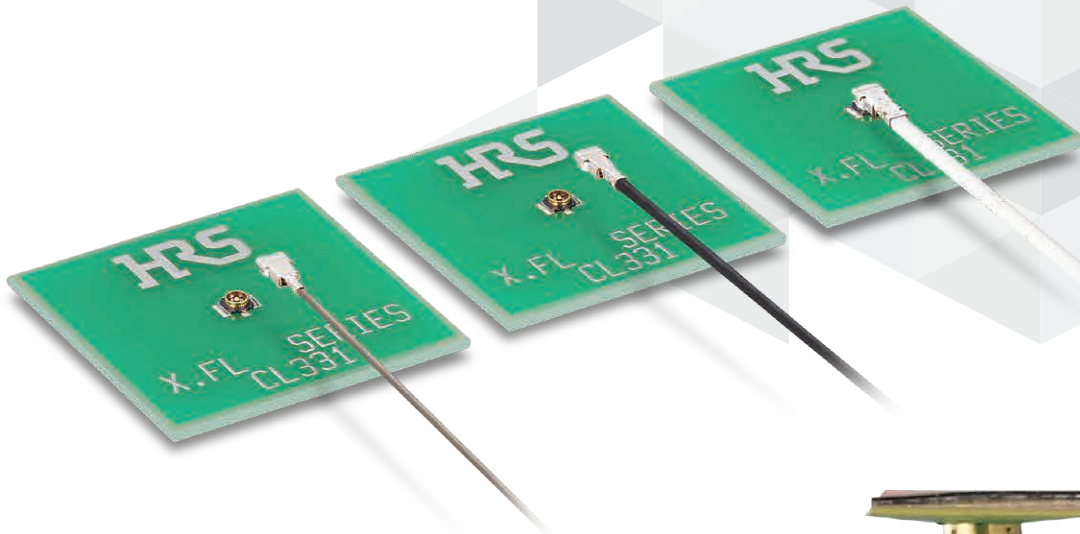

# Features

## 1. Space-saving Design

Contribute to making set devices Small Size.

- Receptacle : 3.2mg
- Right Angle Plug : 22mg (068)
- 15mg (040)
- 16mg (032)
- Plug Receptacle : 5.5mg

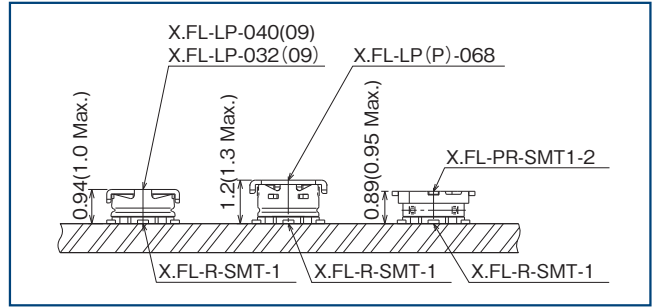

Mated Height Comparison

## 2. PCB Mounting Space 3.4mm<sup>2</sup>

The receptacle requires a footprint of only 3.4mm<sup>2</sup>, which is the same footprint as our W.FL and W.FL2 Series. In addition, the same land patterns can be used.

(Note) The X.FL Series has no mating compatibility with the W.FL2 and W.FL Series.

## 3. RF Performance (up to 12GHz)

High Frequency Performance is showed below.

- ~6GHz :  $\phi$ 0.64
- ~8GHz :  $\phi$ 0.5,  $\phi$ 0.81
- ~12GHz :  $\phi$ 1.13

(Standardized on WiGig modules)

## 4. Ultra-fine Coaxial (Fluorinated Resin Insulated) Cables

Compatible with ultra-fine coaxial cables for smooth and easy installment.

( $\phi$ 1.13,  $\phi$ 0.81,  $\phi$ 0.64,  $\phi$ 0.5 diameter)

## 5. Supports Automatic Mounting

Receptacle and plug receptacle can be pick & place mounted due to the embossed tapping packaging specifications.

## 6. Easy and Good Mating

You can easily insert and remove connectors by using special insertion/ removal tools.

## 7. Halogen-Free and RoHS2 Compliant

The receptacle and plug do not contain chlorine or bromine above the standard value.

\*Defined in accordance with IEC61249-2-21.

## Product Specifications

Nominal Characteristic Impedance	50 $\Omega$	Operating Temperature	-40 to +90°C (90% RH Max.)
Frequency Range	0 to 12GHz	Storage Temperature	-30 to +70°C (90% RH Max.)

Item	Specifications	Conditions
Contact Resistance	<ul style="list-style-type: none"> <li>● X.FL-LP-040(09)</li> <li>● X.FL-LP-032(09)</li> </ul> Center : 25m $\Omega$ Max. Outer : 25m $\Omega$ Max.	Measured at 10mA Max.
	<ul style="list-style-type: none"> <li>● X.FL-LP(P)-068</li> </ul> Center : 25m $\Omega$ Max. Outer : 15m $\Omega$ Max.	
	<ul style="list-style-type: none"> <li>● X.FL-PR-SMT1-2</li> </ul> Center : 25m $\Omega$ Max. Outer : 10m $\Omega$ Max.	
	<ul style="list-style-type: none"> <li>● X.FL-R-SMT-1</li> </ul> Depends on the mating plug	
V.S.W.R.*	<ul style="list-style-type: none"> <li>● X.FL-LP-040(09)</li> </ul> $\phi$ 0.81 Cable V.S.W.R. 1.3 Max. V.S.W.R. 1.4 Max. V.S.W.R. 1.6 Max.	$\phi$ 0.81 Cable 0 ~ 3GHz 3 ~ 6GHz 6 ~ 8GHz
	$\phi$ 0.64 Cable V.S.W.R. 1.3 Max. V.S.W.R. 1.5 Max.	$\phi$ 0.64 Cable 0 ~ 3GHz 3 ~ 6GHz
	<ul style="list-style-type: none"> <li>● X.FL-LP-032(09)</li> </ul> V.S.W.R. 1.3 Max. V.S.W.R. 1.4 Max. V.S.W.R. 1.5 Max.	0 ~ 3GHz 3 ~ 6GHz 6 ~ 8GHz
	<ul style="list-style-type: none"> <li>● X.FL-LP(P)-068</li> </ul> V.S.W.R. 1.3Max. V.S.W.R. 1.4Max. V.S.W.R. 1.7Max.	0 ~ 3GHz 3 ~ 6GHz 6 ~ 12GHz
	<ul style="list-style-type: none"> <li>● X.FL-PR-SMT1-2</li> </ul> V.S.W.R. 1.3Max. V.S.W.R. 1.5Max.	0 ~ 3GHz 3 ~ 6GHz
	<ul style="list-style-type: none"> <li>● X.FL-R-SMT-1</li> </ul> V.S.W.R. 1.3 Max. V.S.W.R. 1.4 Max. V.S.W.R. 1.5 Max. V.S.W.R. 1.6 Max.	0 ~ 3GHz 3 ~ 6GHz 6 ~ 9GHz 9 ~ 12GHz
Insulation Resistance	500M $\Omega$ Min.	Measured at 100V DC
Withstanding Voltage	No insulation breakdown	200V AC for 1 min.

\*V.S.W.R. (Voltage Standing Wave Ratio) Measurement System (Plug type)

The above V.S.W.R. specification values were measured using the measurement system shown below.

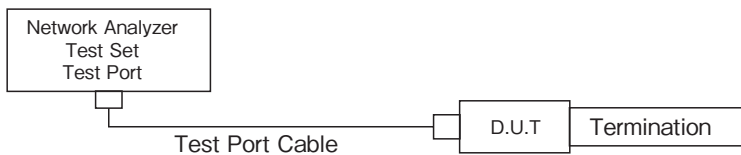

(Note 1) Cable type connectors were measured with SMA conversion adapters attached to the cable assembly at both ends of a compatible 100cm cable.

(Note 2) Board type connectors were mounted to a 50  $\Omega$  glass epoxy board and measurements were conducted with SMA conversion adapters attached.

## Materials / Finish

Item	Component	Materials	Color / Finish
Right Angle Plug	Shell	Phosphor Bronze	Partially Gold Plating
	Insulator	LCP	Black, UL94V-0
	Female Contact	Phosphor Bronze	Gold Plating
Receptacle	Shell	Phosphor Bronze	Partially Gold Plating
	Insulator	LCP	Black, UL94V-0
	Male Contact	Brass	Partially Gold Plating
Plug Receptacle	Shell	Phosphor Bronze	Partially Gold Plating
	Insulator	LCP	Black, UL94V-0
	Female Contact	Phosphor Bronze	Partially Gold Plating

## Product Number Structure

### Cable Assembly Product Number Structure

Refer to the chart below when determining the product specifications from the product number.

The dimension specifications of the X.FL Series cable assembly are as follows.

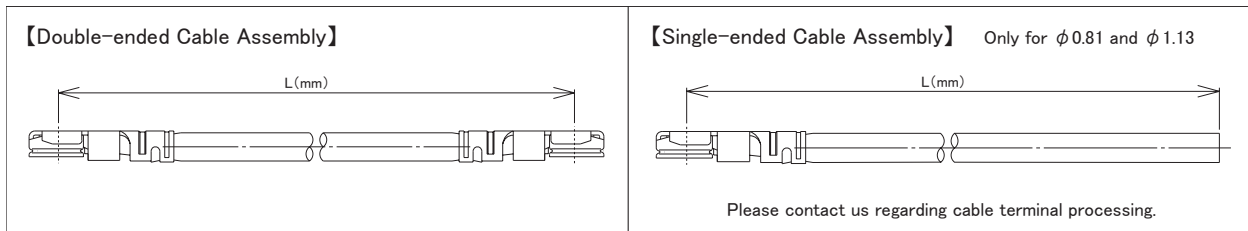

### Applicable Plug : X.FL-LP-040(09)

#### ● $\phi 0.81$ Cable

**X.FL - LP9 - 04N [ ] TV - A - (L)**

①      ②      ③      ④      ⑤      ⑥

① Series Name	X.FL (XFL)	④ Cable Color	1 : White 2 : Black
② Assembly Type	LP9 : Single-ended 2LP9 : Double-ended	⑤ Cable Outer Conductor	TV : Tin Plated Braided Wire
③ Cable Type	04N : $\phi 0.81$ Coaxial Cable	⑥ Total Length L (mm)	L length in mm

#### ● $\phi 0.64$ Cable

**X.FL - 2LP9 - 044N [ ] TS - A - (L)**

①      ②      ③      ④      ⑤      ⑥

① Series Name	X.FL (XFL)	④ Cable Color	1 : White 2 : Black 4 : Blue
② Assembly Type	2LP9 : Double-ended (Not covered single ended)	⑤ Cable Outer Conductor	TS : Tin Plated Spiral Winding Wire
③ Cable Type	044N, 044Y : $\phi 0.64$ Coaxial Cable	⑥ Total Length L (mm)	L length in mm

## ■ Applicable Plug : X.FL-LP-032(09)

### ● $\phi$ 0.5 Cable

## X.FL - 2LP9 - 032H [ ] TS - A - (L)

①                      ②                      ③                      ④                      ⑤                      ⑥

① Series Name	X.FL (XFL)	④ Cable Color	1 : White 2 : Black
② Assembly Type	2LP9 : Double-ended (Not covered single ended)	⑤ Cable Outer Conductor	TS : Tin Plated Spiral Winding Wire
③ Cable Type	032H : $\phi$ 0.5 Coaxial Cable or 032N	⑥ Total Length L (mm)	L length in mm

## ■ Applicable Plug : X.FL-LP(P)-068

### ● $\phi$ 1.13 Cable

## X.FL - LP P - 068N [ ] T - A - (L)

①                      ②                      ③                      ④                      ⑤                      ⑥                      ⑦

① Series Name	X.FL (XFL)	⑤ Cable Color	1 : Grey 2 : Black
② Assembly Type	LP9 : Single-ended 2LP9 : Double-ended	⑥ Cable Outer Conductor	T : Tin Plated Braided Wire
③ Connection Type	P : Batch Connection Type		
④ Cable Type	068N : $\phi$ 1.13 Coaxial Cable	⑦ Total Length L (mm)	L length in mm

## ■ Standard Tolerances for (L)

Total Length (mm)	Standard Tolerances (mm)
$35 \leq L \leq 200$	$\pm 4$
$200 < L \leq 500$	$\pm 8$
$500 < L \leq 1000$	$\pm 12$
$1000 < L$	$\pm 1.5\%$

(Note) Shortest length L=35mm (X.FL-LP(P)-068 is 100mm)

## Cable Assembly Plug

X.FL-LP-040(09) (Applicable Cable : Outer Diameter  $\phi 0.81$ ,  $\phi 0.64$ )

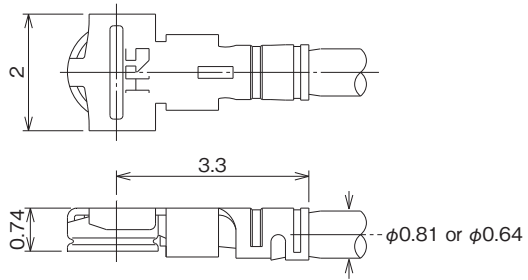

● X.FL-LP-032(09) (Applicable Cable : Outer Diameter  $\phi 0.5$ )

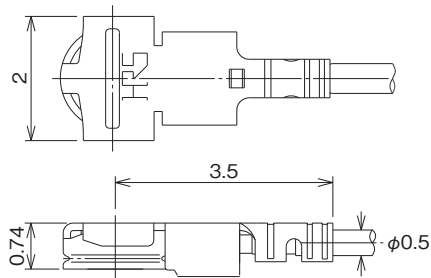

● X.FL-LP(P)-068 (Applicable Cable : Outer Diameter  $\phi 1.13$ )

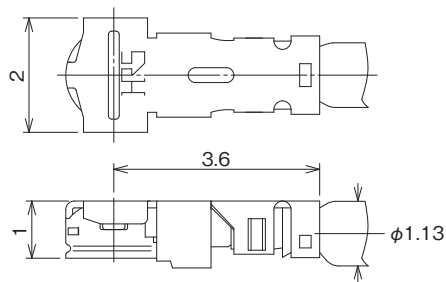

## ● Cable Guide

Cable Type	Cable Mark	Cable Specification						
		Center Conductor	Dielectric Diameter	Outer Conductor	Jacket Diameter	Nominal Impedance	Nominal Attenuation	
							3GHz	6GHz
φ 0.81mm Cable	04	7/0.05 (36 AWG) Silver plated annealed copper wire	φ 0.40 Fluorine Resin	Single-layer braided wire Tin plated	φ 0.81 FEP	50 Ω	5.4dB/m	8.0dB/m
φ 0.64mm Cable	044		φ 0.44 Fluorine Resin	Spiral winding wire Tin plated	φ 0.64 FEP		4.6dB/m	6.5dB/m
φ 0.5mm Cable	032	7/0.04 (38 AWG) Silver plated annealed copper wire	φ 0.32 Fluorine Resin	Spiral winding wire Tin plated	φ 0.5 FEP		6.1dB/m	8.6dB/m
φ 1.13mm Cable	068	7/0.08 (32 AWG) Silver plated annealed copper wire	φ 0.68 Fluorine Resin	Single-layer braided wire Tin plated	φ 1.13 FEP		3.7dB/m	5.4dB/m

## Receptacle

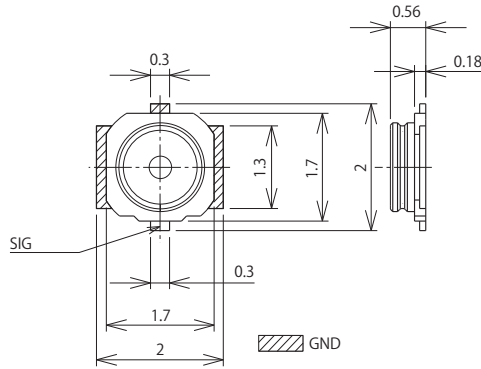
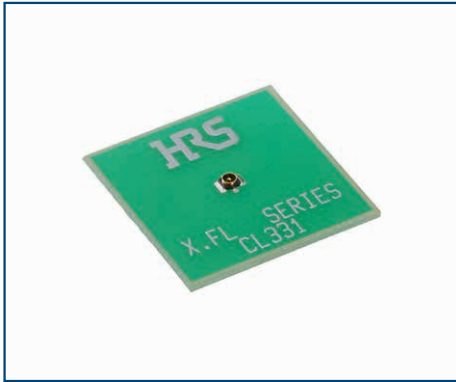

Unit : mm

Part No.	HRS No.	Purchase Unit	R	RoHS2, Halogen-free
X.FL-R-SMT-1(02)	CL0331-0701-8-02	500pcs per reel	180	Yes
X.FL-R-SMT-1(80)	CL0331-0701-8-80	10,000pcs per reel	330	
X.FL-R-SMT-1(90)	CL0331-0701-8-90	20,000pcs per reel	380	

### Recommended PCB Mounting Pattern

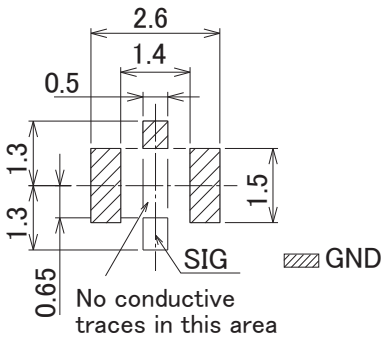

(Note) The pattern is the same as the W.FL and W.FL2 connectors.

### Embossed Carrier Tape Dimensions (JIS-C-0806/IEC 60286 Compliant)

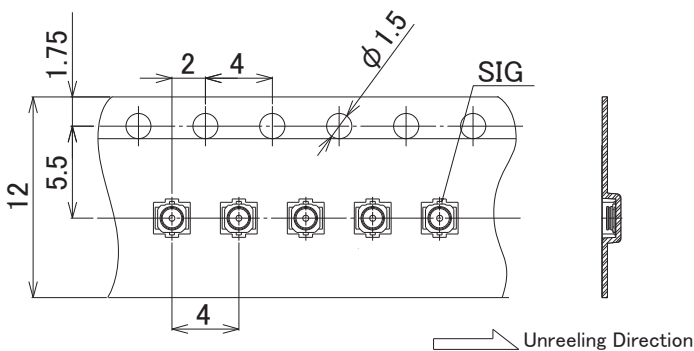

### Reel Dimensions

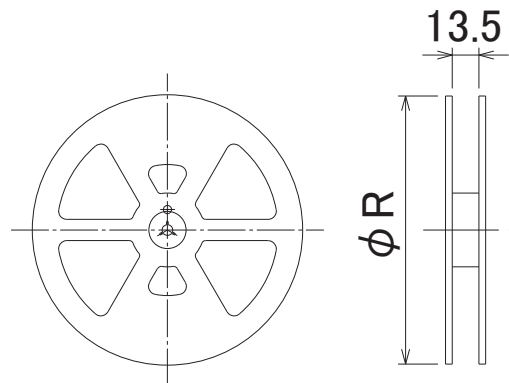

## Plug Receptacle

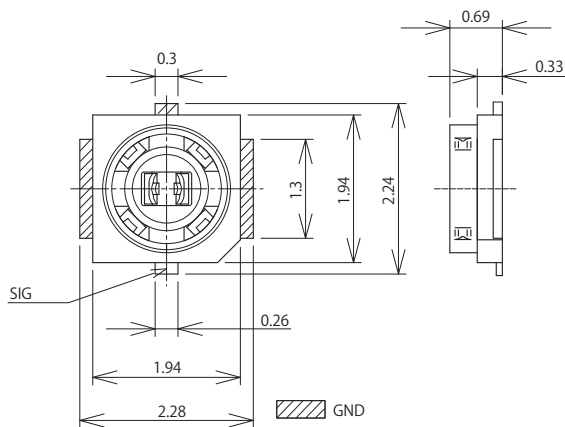

Unit : mm

Part No.	HRS No.	Purchase Unit	R	RoHS2, Halogen-free
X.FL-PR-SMT1-2(80)	CL0331-0713-7-80	10,000pcs per reel	330	Yes
X.FL-PR-SMT1-2(25)	CL0331-0713-7-25	20,000pcs per reel	380	

### Recommended PCB Mounting Pattern

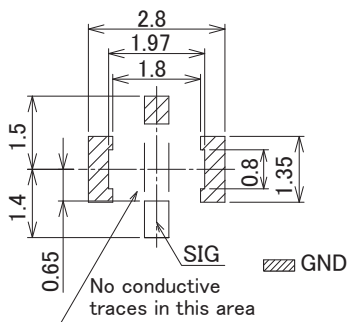

### Embossed Carrier Tape Dimensions (JIS-C-0806/IEC 60286 Compliant)

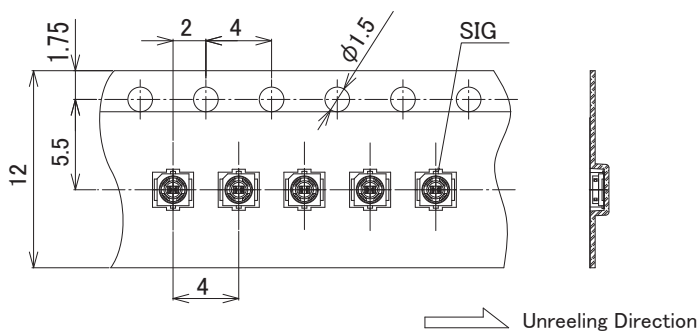

### Reel Dimensions

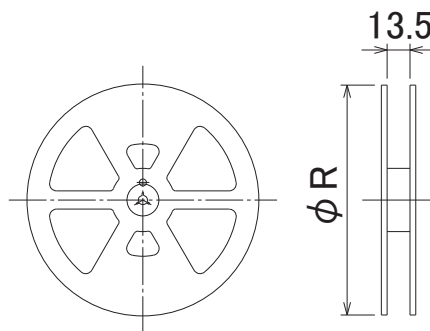

## Conversion Adapter

### ● SMA Conversion Adapter (Mated Portion - X.FL Side : Jack, SMA Side : Plug)

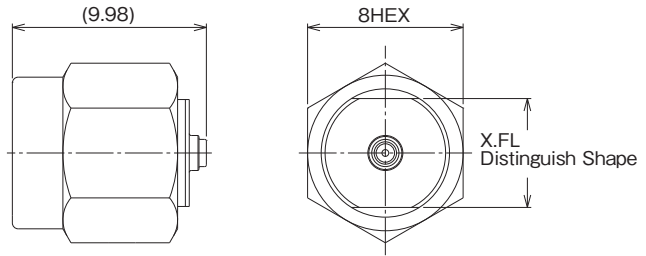

Part No.	HRS No.	RoHS2
HRMP-X.FLJ	CL0311-0435-1-00	Yes

(Note) Since the X.FL side mating portion has a weaker lock than standard products, it cannot be used for purposes other than performance measurement.

### ● SMA Conversion Adapter (Mated Portion - X.FL Side : Plug, SMA Side : Jack)

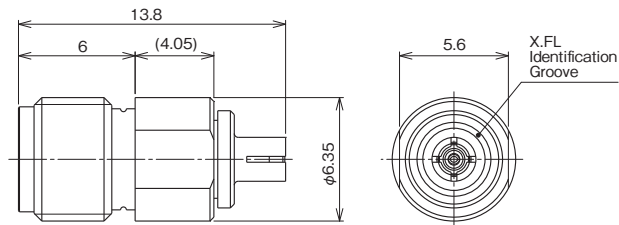

Part No.	HRS No.	RoHS2
HRMJ-X.FLP	CL0311-0436-4-00	Yes

(Note) Since the X.FL side mating portion has a weaker lock than standard products, it cannot be used for purposes other than performance measurement.

● SMA Conversion Probe  
(Mated Portion - X.FL Side : Plug (Without Lock), SMA Side : Jack)

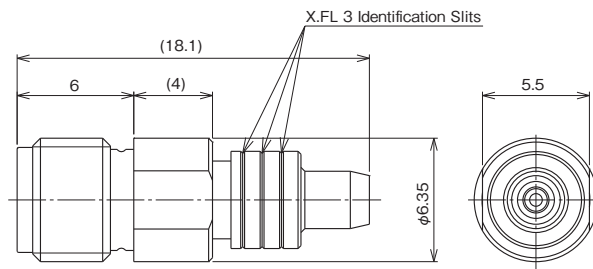

Part No.	HRS No.	RoHS2
HRMJ-X.FLP-ST3	CL0311-0450-5-00	Yes

(Note) This connector is used by pressing the mating portion of the X.FL side with the mating portion of X.FL-R-SMT-1.

● SMA Conversion Adapter  
(Mated Portion : SMA Jack (Measuring Device Connection Side) - SMA Plug)

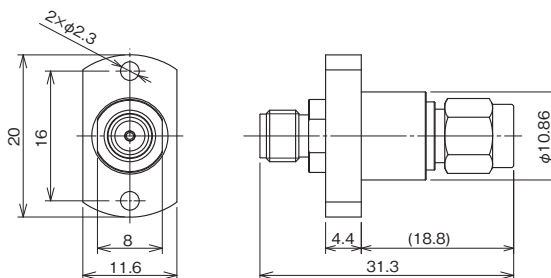

Part No.	HRS No.	RoHS2
HRM-PA-PJ(F)-1(40)	CL0323-0805-9-40	Yes

(Note) HRMJ-X.FLP-ST3 absorbs misalignment when it is mated with the plug (coupling side) and the jack is connected to the measuring device.

● Probe for Inspect of Multiple Receptacles Mounted at a Narrow Pitch  
(Mated Portion : X.FL Plug (Without Lock) - ML51 Jack)

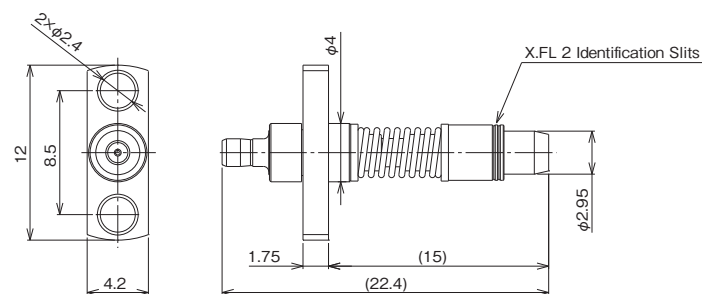

Part No.	HRS No.	RoHS2
X.FLP-ML51.J-PA(F)-ST	CL0311-0469-3-00	Yes

(Note) Hirose's ML51 is used for the measuring device interface. It is ideal for simultaneous inspection of multiple receptacles mounted at a narrow pitch.

● **Harness for Narrow Pitch Probe Connection**  
**(Mated Portion : SMA Plug (Measuring Device Connection Side) ML51 Plug)**

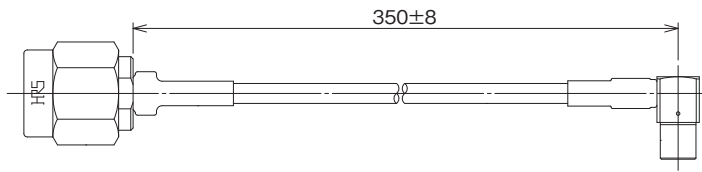
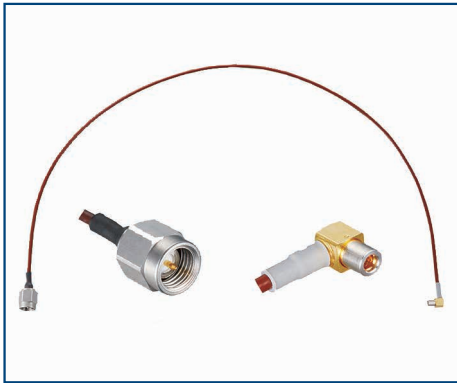

Part No.	HRS No.	RoHS2
HRMP-ML51LP-DTR178-350RS	CL0321-4926-2-01	Yes

(Note) Used to connect X.FLP-ML51J-PA(F)-ST and the measuring device. It is recommended to provide slack to the cable length so that it can absorb misalignment smoothly.

## Inspection Probe

### ● HRMJ-X.FLP-ST3 and HRM-PA-PJ(F)1 Combination and Usage

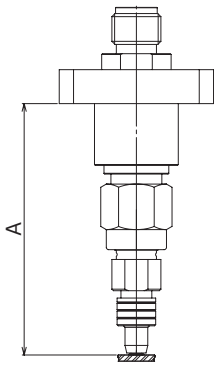
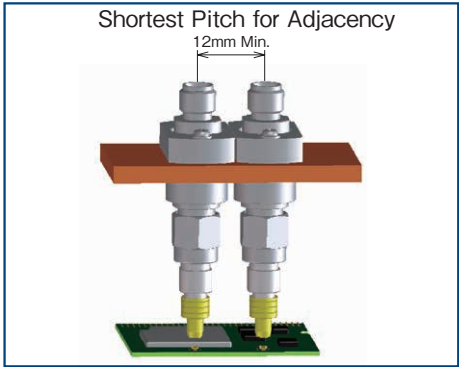

Flange to Board Surface	A
Recommendation for Measurement	31.9 ± 0.2
Starting Load	32.6

### ● X.FLP-ML51.J-PA(F)-ST and HRMP-ML51LP-DTR178-350RS Combination and Usage

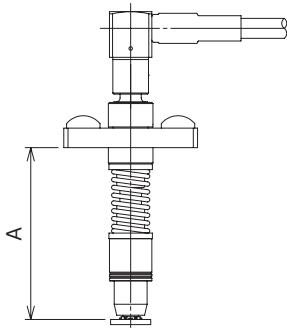
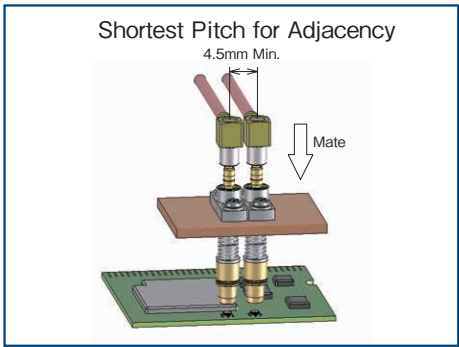

Flange to Board Surface	A
Recommendation for Measurement	14.3 ± 0.2
Starting Load	15.3

Note : For the inspection probe, be careful not to tilt the tip of the contact due to the tensile load of the connecting cable.

Dec.1.2024 Copyright 2024 HIROSE ELECTRIC CO., LTD. All Rights Reserved.

## SMA Connector that Can Be Used With X.FL-LP(P)-068

### ● Straight Plug

This product can be ordered only in terminated cable assemblies.

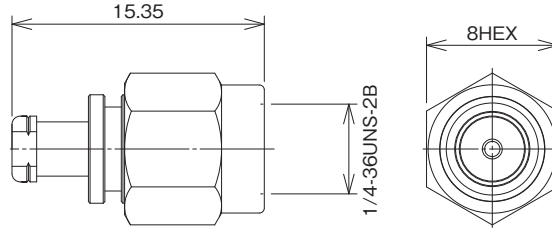

Part No.	HRS No.	RoHS2
HRM(G)-200-066PBN	CL0323-0914-0-00	Yes

(Note) Even though it is an ultra-fine wire connection type, the straight plug maintains stable characteristics up to 12GHz due to the optimized design. (Impedance matching type)

### ● Straight Jack

This product can be ordered only in terminated cable assemblies.

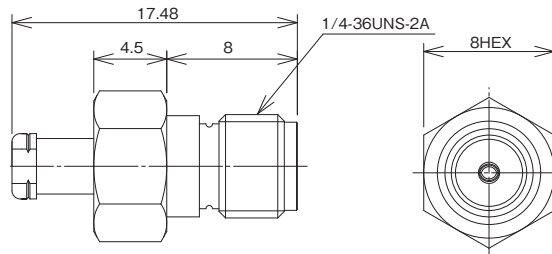

Part No.	HRS No.	RoHS2
HRM(G)-200-066JBN	CL0323-0959-0-00	Yes

(Note) Even though it is an ultra-fine wire connection type, the straight jack maintains stable characteristics up to 12GHz due to the optimized design. (Impedance matching type)

## Tool

### ● Plug Mating Tool (Space-saving Type)

This tool is used for plug mating.

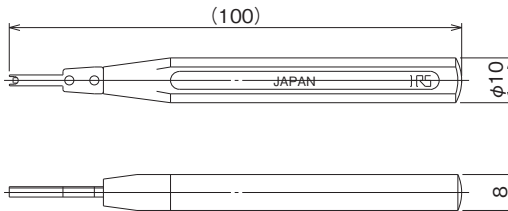

Part No.	HRS No.	RoHS2
W.FL-LP-IN (Note)	CL0331-0323-2-00	Yes

Note: Compatible with the X.FL connector.

### ● Plug Mating and Unmating Tool

One end of this combined purpose tool is used for mating and the other end is used for unmating.

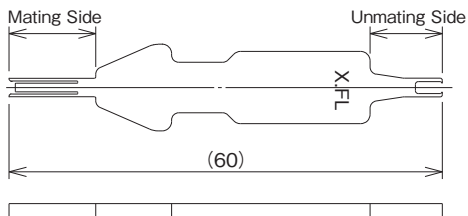

Part No.	HRS No.	RoHS2
X.FL-LP-IN.OUT1 (Note)	CL0331-0715-2-00	Yes

(Note) X.FL-LP-IN.OUT1 is special tool for both insertion and extraction.

## Precautions

### 1. Plugs

#### 1. Mating/Unmating

(1) To unmate, use the unmating side of the plug mating and unmating tool X.FL-LP-IN.OUT1 as shown in the following figure.

[How to unmate the plug]

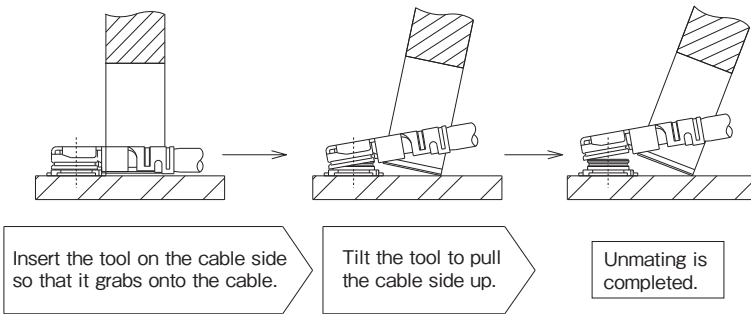

Do not unmate the plug by pulling on the cable, this can damage the connector performance.

(2) To mate, use the mating side of the plug mating and unmating tool X.FL-LPIN.OUT1 or the plug mating tool W.FL-LP-IN. Align the mating axes between both of the connectors and check that the shell is properly aligned. The connector should be inserted perpendicularly as much as possible. (Refer to the following figure) Do not attempt to insert the connector at an extreme angle as it may result in connector damage.

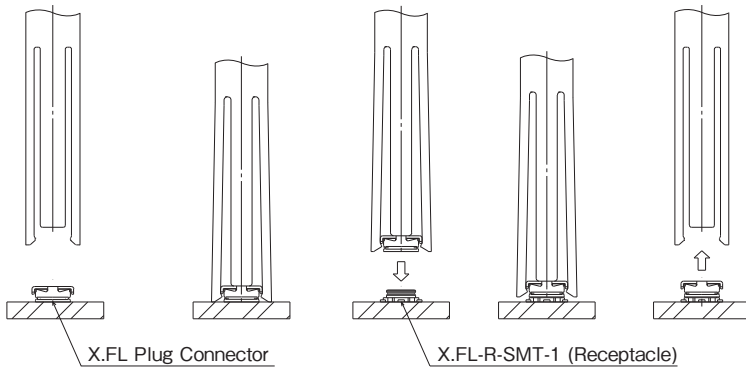

#### 2. Tolerable load to a cable after mating

Once the connector has been mated do not apply forces exceeding the values in the diagram below.

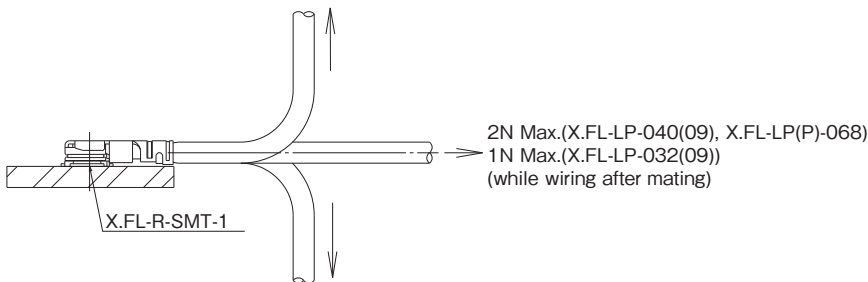

Be careful when applying stress that results in cable lifting as it may cause the connectors to unmate easily. When routing in a way that causes the cable to lift, it is recommended to place cushioning on the plug in order to prevent unmating. (Refer to the example below).

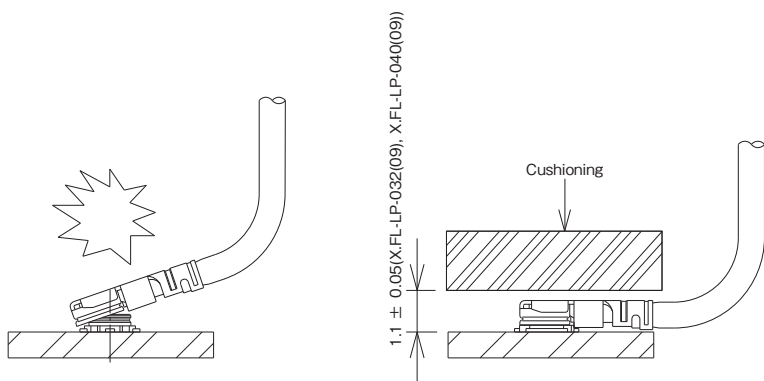

**3. Precautions**

Do not use excessive prying to mate or unmate the connectors as it may lead to damage.

**4. Recommended orientation for mating the plug cable assembly to the receptacle**

It is recommended that the SIG contact direction of the receptacle be offset from the cable pull direction of the plug cable assembly by at least 45°

(To prevent disturbance of high frequency characteristics due to locally low impedance)

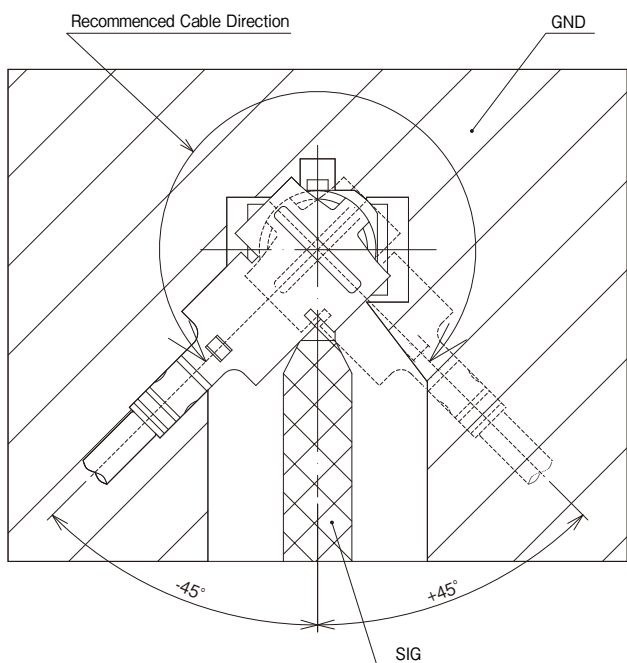

## 2. Plug Receptacles

### 1. Mating

This product should be mated by hand.

Do not apply an excessive load or over handle during the mating process as doing so may result in connector damage.

#### [Mating Procedure]

(1) Before inserting the connector, bring the mating surface of the plug receptacle (X.FL-PR-SMT1-2) into slight contact with the receptacle (X.FL-R-SMT-1). Shift them back and forth and left and right to align the mating axes.

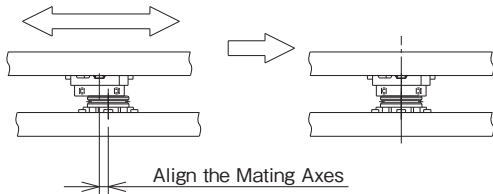

(2) Confirm that the mating axes are aligned by checking for position stability.

When the connector is partially mated with the receptacle it will not move even when a force is applied.

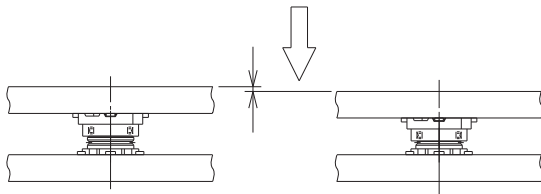

(3) Push the connector down perpendicularly until you feel it click.

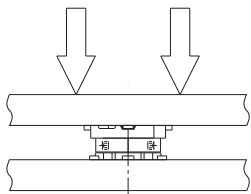

(4) If the mating axes cannot align and the plug cannot be inserted, please check that the contact portion of the female terminal on the plug receptacle has not been damaged as a result of mold deformation from collision with the receptacle shell.

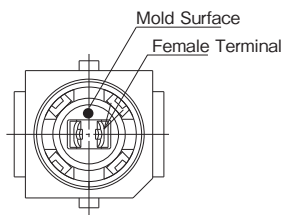

### 2. Unmating

When unmating, pull the connector in the direction perpendicular to the mating surface as much as possible.

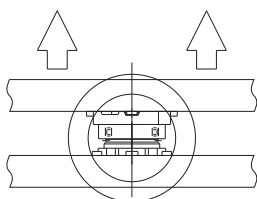

However it may be difficult to remove perpendicularly from a thin, unlined board (FPC, etc.). In such cases remove diagonally as shown in the left diagram. Avoid removing the connector from the direction shown in the right diagram.

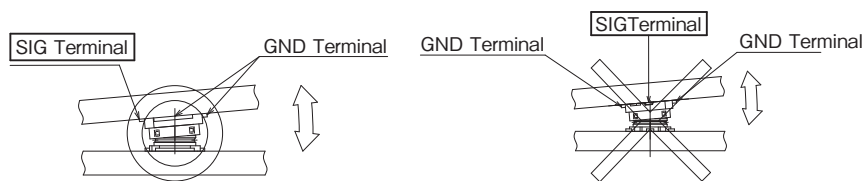

**3. Precautions**

Do not mate or unmate a connector with an excessive prying force. It may cause connector damage.

**4. Notes for mounting**

Avoid mounting multiple connectors of this type on the same circuit board.  
 (If it is unavoidable to mount multiple connectors, take necessary measures for use, such as separating the circuit board between the connectors.)  
 When the connector is mounted on an FPC, insufficient stiffness may lead to land pattern separation or solder separation. It is recommended that the FPC should be lined with a reinforcing film.

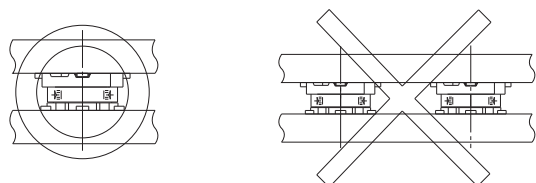

**5. Precautions**

- (1) Do not mate or unmate a connector with an excessive prying force. It may cause connector damage.
- (2) The connector may become disconnected if it is dropped, or extreme stress is applied to the FPC.  
 To prevent disconnection, secure the connector in place by pushing down in the mating direction with the panel or cushioning material.

**3.Reflow Conditions of Receptacles and Plug Receptacles**

<p>(1) Recommended Reflow Temperature Profile</p>	<p>(1) Temperature refers to the temperature of the PCB surface at the terminal leads.                  (2) Reflow soldering should be performed at a printed circuit surface temperature of 250°C Max.                  (3) The temperature profile may vary depending on board size, solder used and solder thickness.</p>
<p>(2) Recommended Metal Mask Thickness</p>	<p>0.1mm to 0.12mm</p>
<p>(3) Reflow Cycles</p>	<p>2 times</p>

Dec.1.2024 Copyright 2024 HIROSE ELECTRIC CO., LTD. All Rights Reserved.

## 4. Operating Environment and Storage Conditions

---

### 1. Operating Environment

This product was designed for use in a normal environment.

Please be advised that using this product in the environments described below may result in discoloration and other types of degradation.

- Exposure to excessive amounts of fine particles and dust.
- Regions/ areas with a high concentration of gases like sulfur dioxide, hydrogen sulfide and nitrogen dioxide.
- Areas with drastic temperature changes, such as locations near a heater.

### 2. Storage Conditions

Store this product in Hirose's packaging or similar conditions.

Temperature: -10 to +40°C, Humidity: 85% Max. (recommended storage conditions)

We recommend the product be used within six months from delivery.

Products that have been stored beyond the recommended storage period need to be tested for mounting and solderability before use.

## While Taking into Consideration

Specifications mentioned in this catalog are reference values.

When considering to order or use this product, please review the Drawing and Product Specifications sheets.

Use an appropriate cable when using the connector in combination with cables.

If considering usage of a non-specified cable, please contact your sales representative.

If assembly process is done by jigs & tools which are not identified by Hirose, the warranty of the product may be affected.

If considering usage for below mentioned applications, please contact your sales representative.

In cases where the application will demand a high level of reliability, such as automotive, medical instruments, public infrastructure, aerospace/defense etc. Hirose must review before assurance of reliability can be given.