

Transfer or duplication of this document as well as the utilisation or communication of its content are not permitted unless express consent is granted. Violations give rise to claims for damages. All rights reserved in case of patent, utility model or design patent registrations.

Weitergabe sowie Vervielfältigung dieses Dokuments, Verwertung und Mitteilung seines Inhalts sind verboten, soweit nicht ausdrücklich gestattet. Zuwiderhandlungen verpflichten zu Schadenersatz. Alle Rechte für den Fall der Patent-, Gebrauchsmuster- oder Designeintragung vorbehalten.

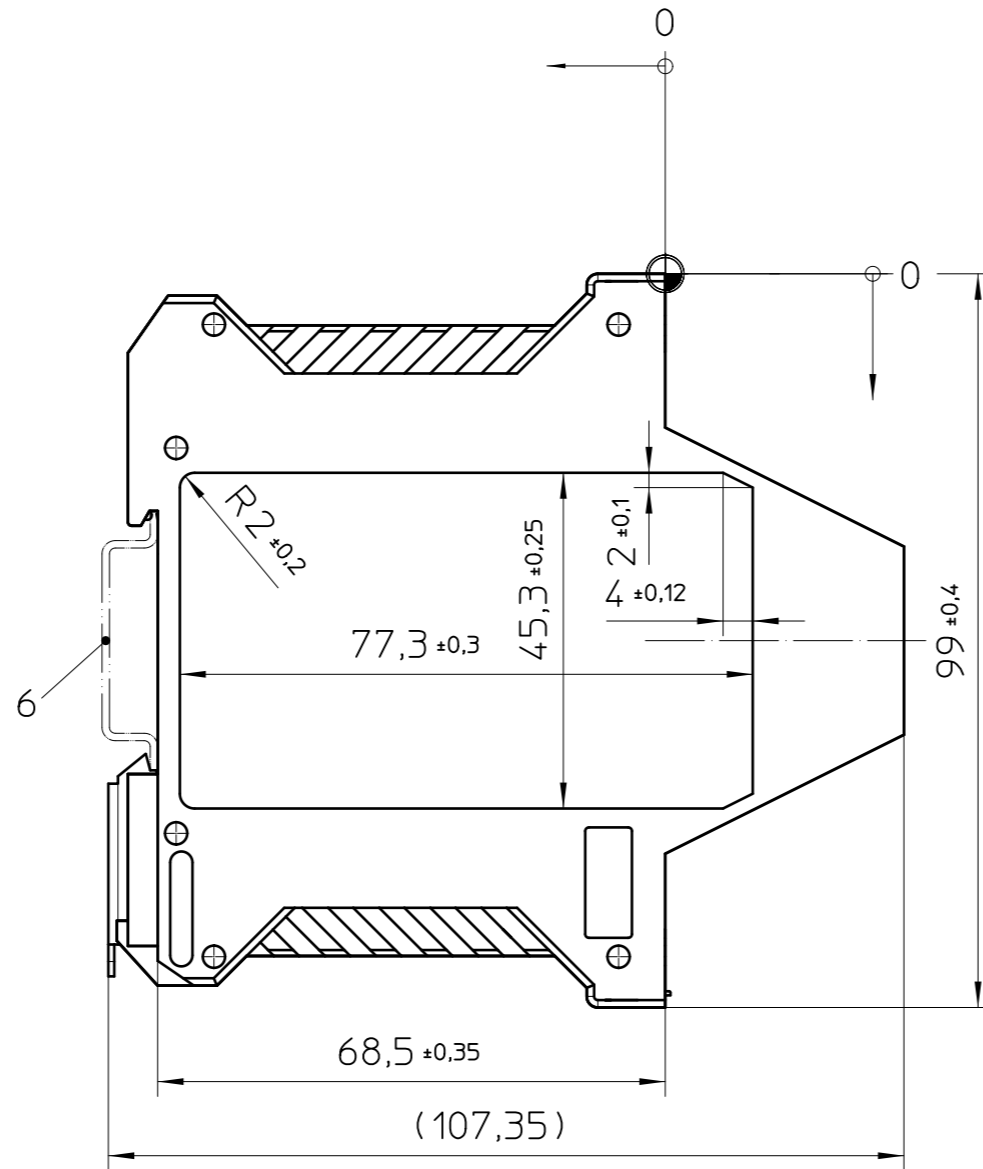

height  
width  
depth

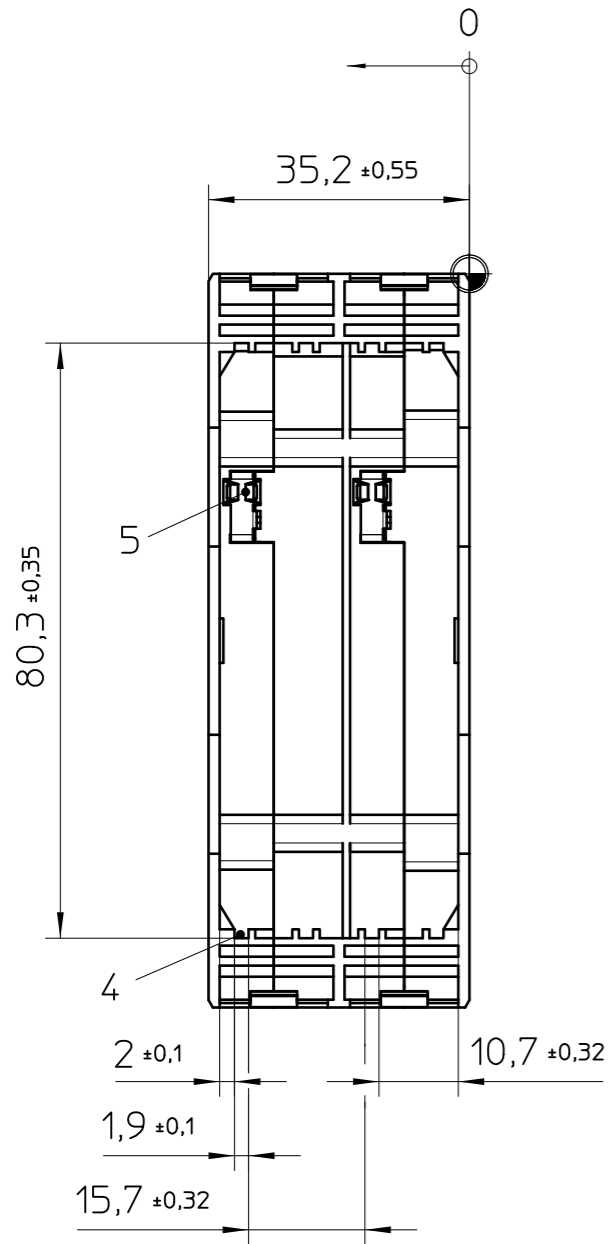
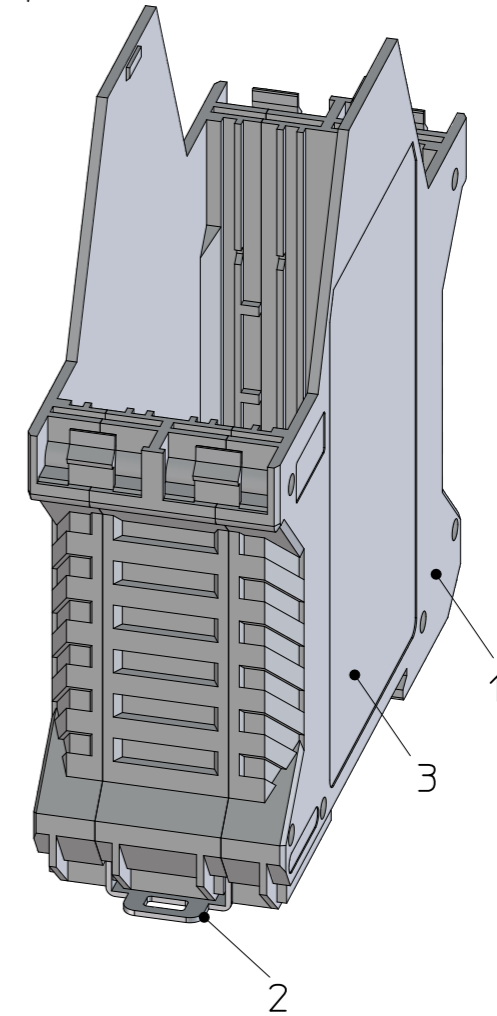

General Information

- 1. ME 35 UT
- 2. Foot catch
- 3. Marking area
- 4. PCB guidance
- 5. FE contact
- 6. Mounting rail like EN 60715: TH 35-7,5/15 or mounting rail TH 35-15x1,5 similar to EN 60715
- ⊕ = Workpiece zero point for mechanical processing

- Simplified representation, exemplary shown in gray
- Document excluded from change process
- CAD Data see Download-Center on [www.phoenixcontact.com](http://www.phoenixcontact.com)
- Linear dimensions [mm]
- Tolerances, apply in a normal climate according to DIN 50014-23/50-2, with about 2% (% by weight) moisture content.
- Recommended PCB outline on [www.phoenixcontact.com](http://www.phoenixcontact.com) webcode: #0512

	document-No. / RI	date	scale
	00857530 / 02	19.12.2025	1:1
	ident.-No.	document-type	
	2202888	TECDC 2D_Productdrawing	
page 1	of 1	description	
		ME 35 UTG/FE1 KMGY	