

BOTTOM PART

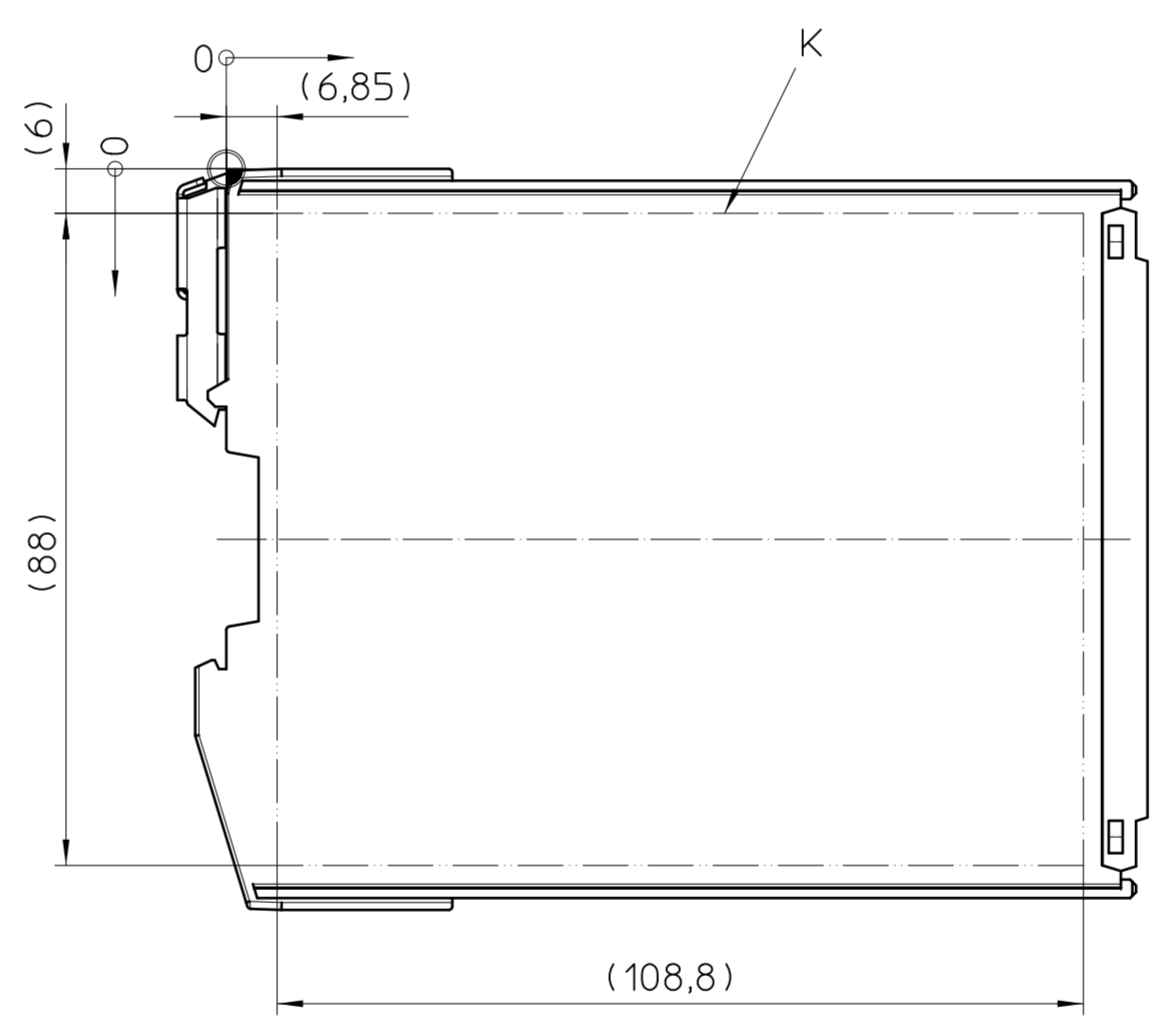

Transfer or duplication of this document as well as the utilisation or communication of its content are not permitted unless express consent is granted. Violations give rise to claims for damages. All rights reserved in case of patent, utility model, or design patent registrations. Tolerance specifications do not include clearances inherent in the design.

width
height
depth

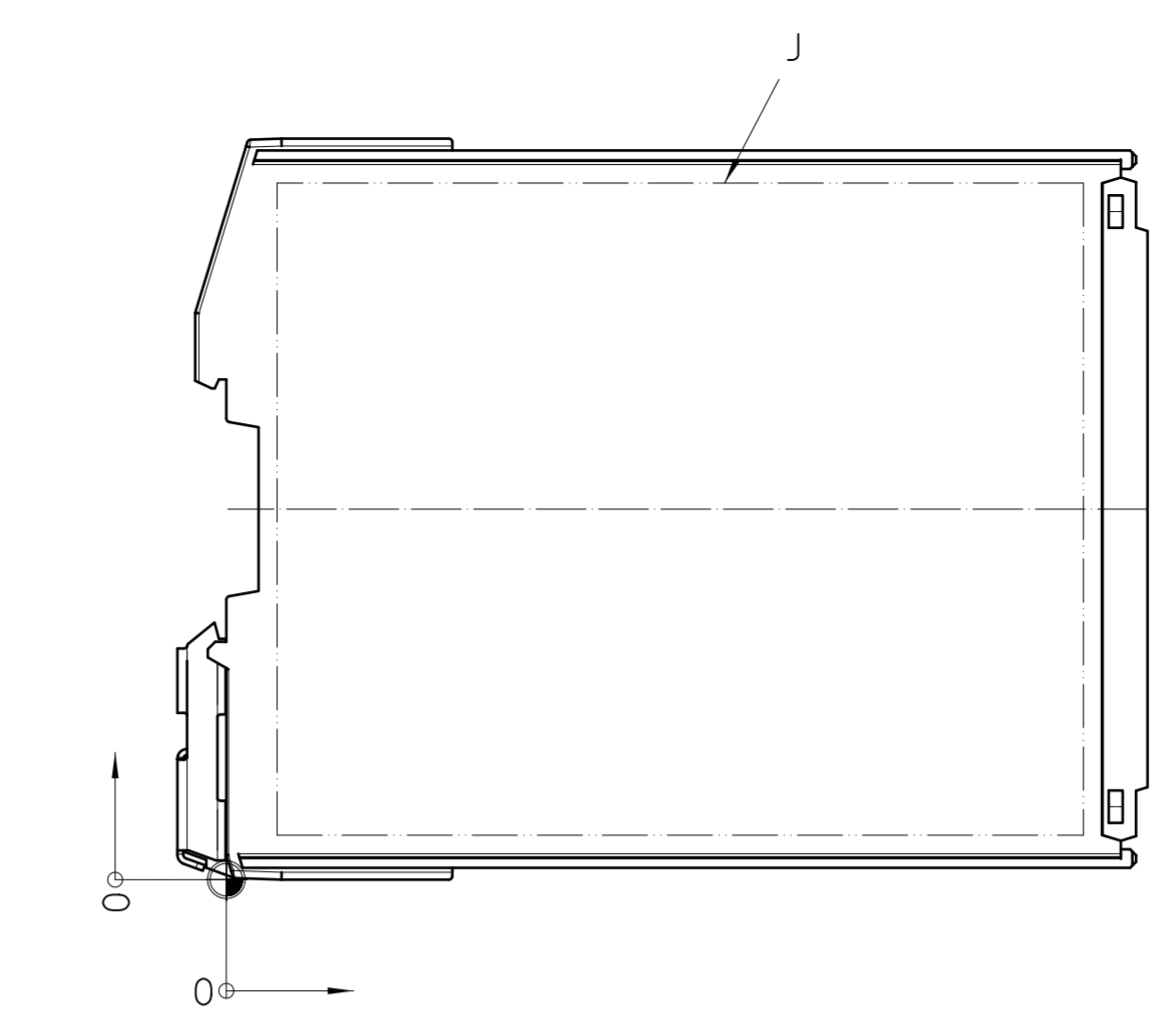
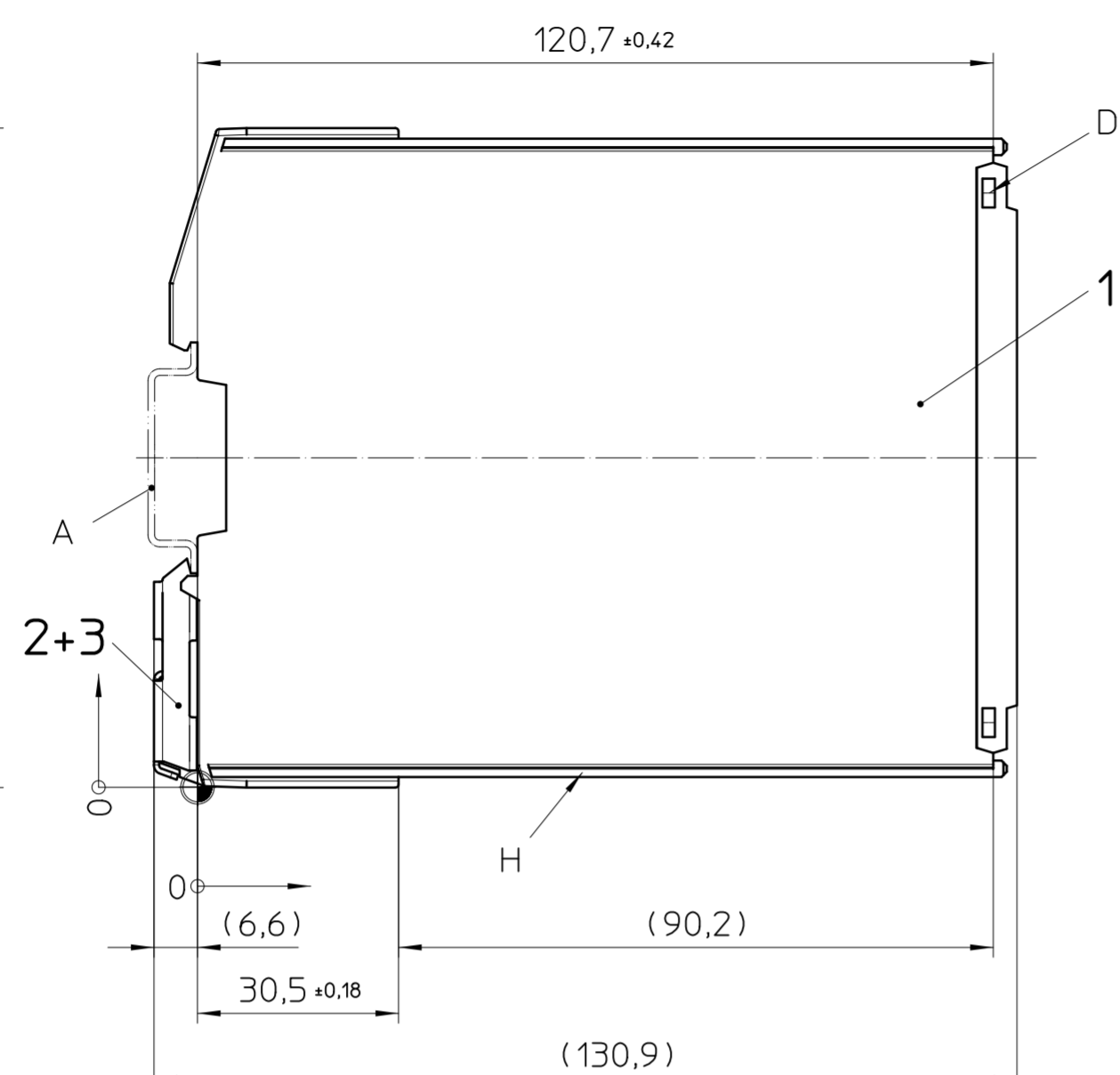
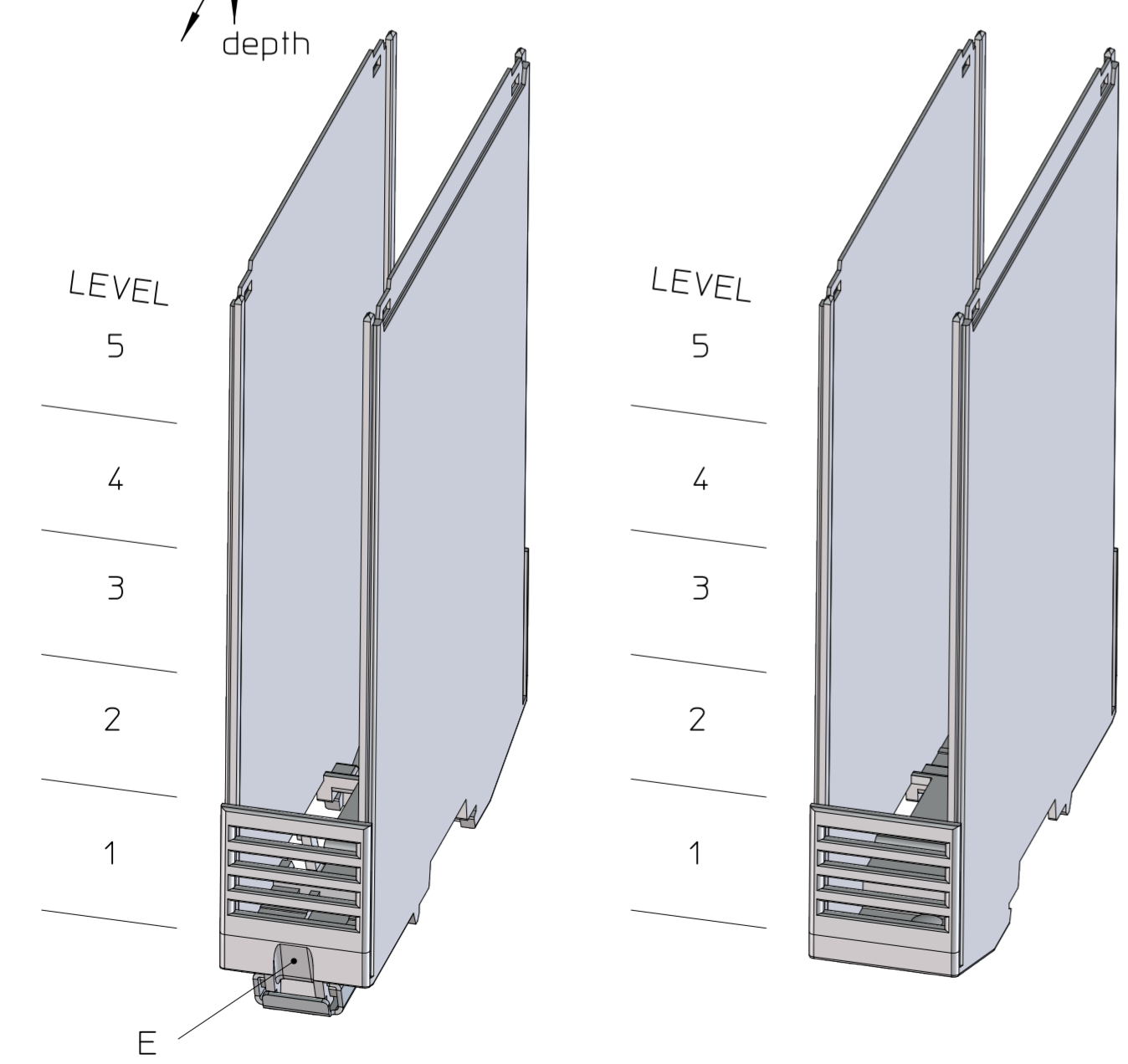

General Information:

- Simplified representation, exemplary shown in gray.
- Tolerances apply in a normal climate according to DIN EN ISO 291-23/50-2, PA plastic parts with about 2% (% by weight) moisture content.
- Workpiece zero point for mechanical processing
- Tolerances for printing DIN ISO 2768-m
- Web: www.phoenixcontact.com webcode: #1635

Additional Information:

- A. Mounting rail like EN 60715, TH 35-7,5 or mounting rail similar to EN 60715, TH 35-15x1,5
- B. PCB t=1,6±0,2
- C. Guidance slot for TBUS8 . . .
- D. Opening for fixing ICS25-C100 . . . or ICS25-TL100 . . .
- E. Notch for locking release, by screw driver
- F. Opening for ICS-FE-CONTACT
- G. Fixing PCB
- H. Guidance for ICS25-F . . . or ICC25 . . .
- I. PCB guidance
- J. Max. marking area left, with standard printing process, other printing processes on request.
- K. Max. marking area right, with standard printing process, other printing processes on request.

Pos.	QTY	Description	Material
1	1	BOTTOM PART	PA
2	1	FOOT CATCH	STL
3	1	SPRING	STL

	document-no. / ri	article-no.	scale	- Simplified representation - Document excluded from change process - Linear dimensions (mm)
	01067039 / 02	1072527	1:1	
	date	document-type		
	29.08.2024	TECDOC_2D_Productdrawing		
page 1	of 1	description ICS25-B100X120-V-9005		

Weitergabe sowie Vervielfältigung dieses Dokuments, Verwertung und Mitteilung seines Inhalts sind verboten, soweit nicht ausdrücklich gestattet. Zuwiderhandlungen verpflichten zu Schadensersatz. Alle Rechte für den Fall der Patent-, Gebrauchsmuster- oder Designeintragung vorbehalten. Bauartbedingtes Spiel ist in den Toleranzangaben nicht berücksichtigt.