

CUSTOMER DRAWING

REVISION			
ZONE	REV.	DESCRIPTION	DATE
ALL	A	INITIAL RELEASE	2021-08-28
A3,B2	B	ADD DUSTCAP AND NOTE 3	2021-09-24
C2	C	ADD MARKING	2022-08-11
A1,B1,A3	D	UPDATE SPECIFICATIONS AND NOTE	2022-12-27

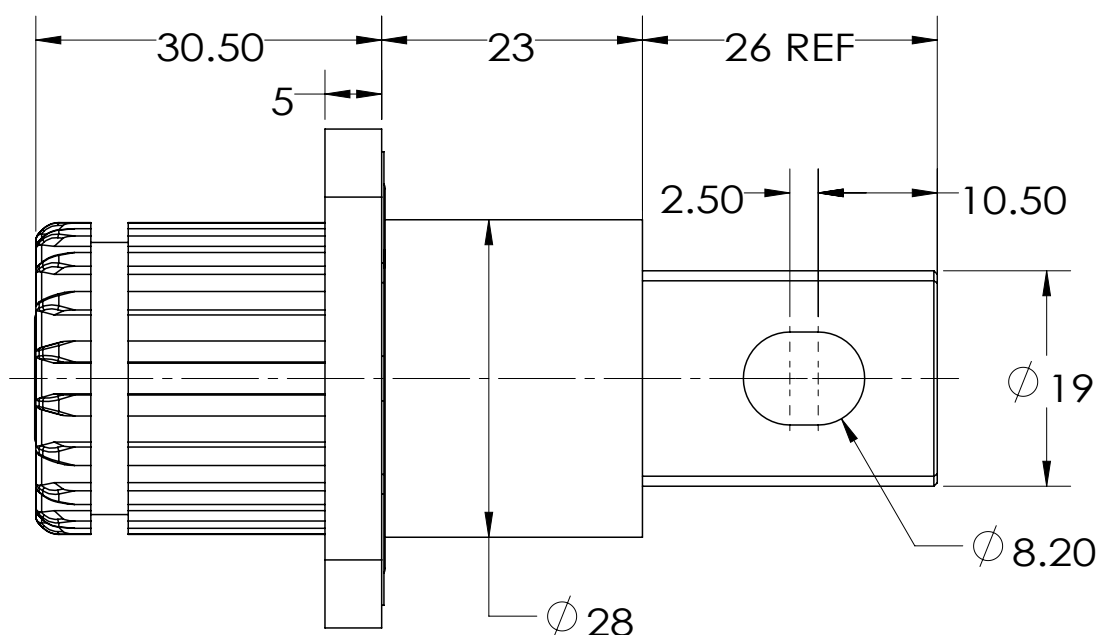
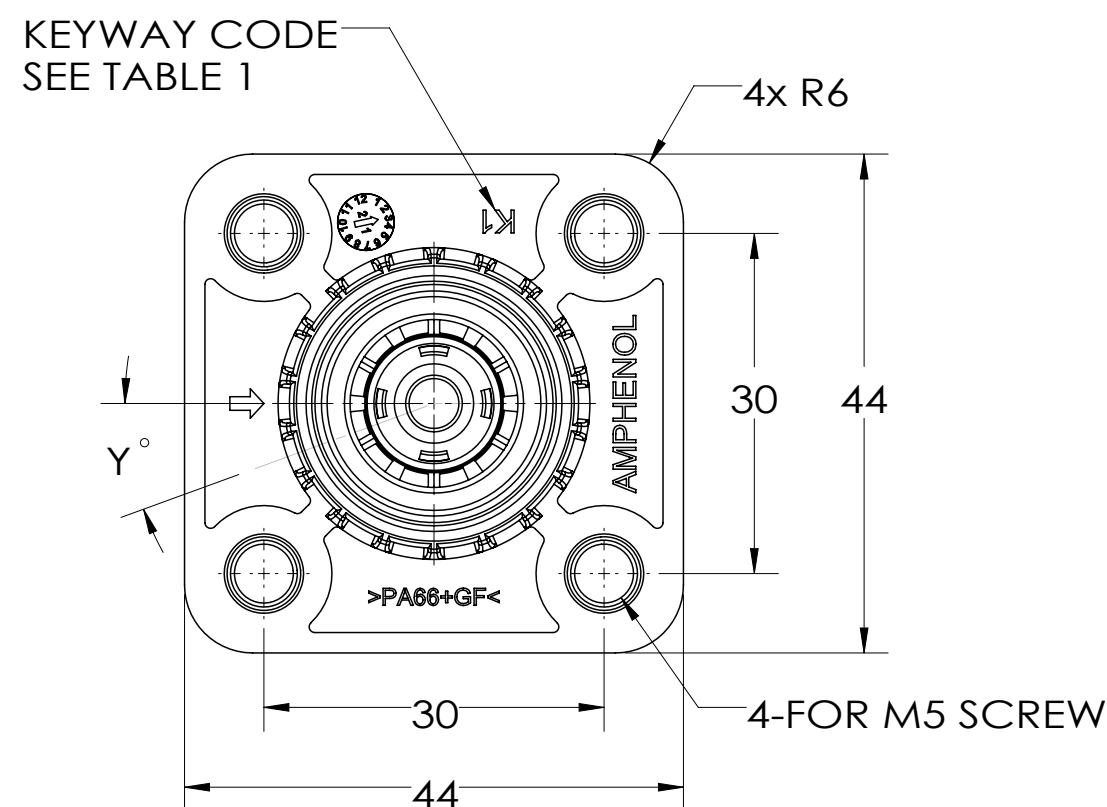

PART NUMBER: C10-779598- () () () ()

COLOR
PIN TYPE

KEYWAY
SEALING

CODE NUMBER: SLPHIRD () P () () ()

PIN TYPE
SEALING

KEYWAY
COLOR

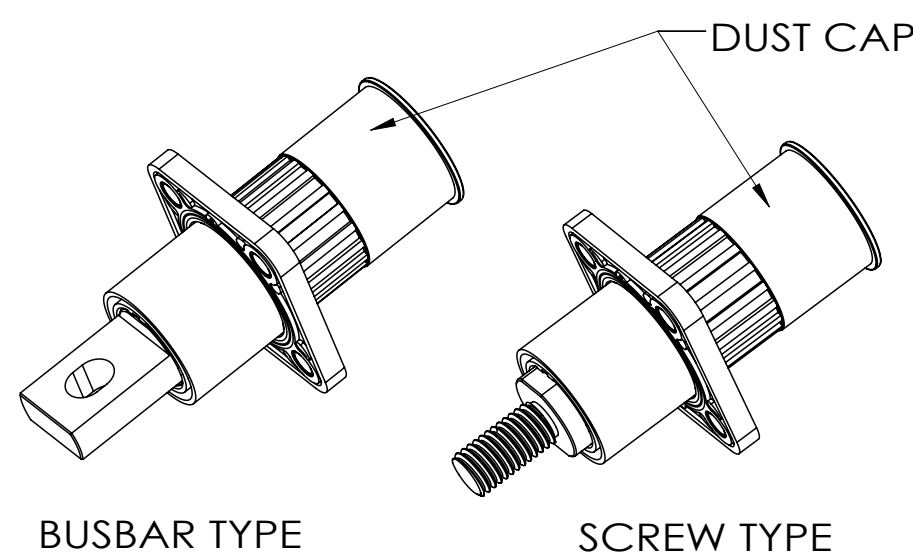
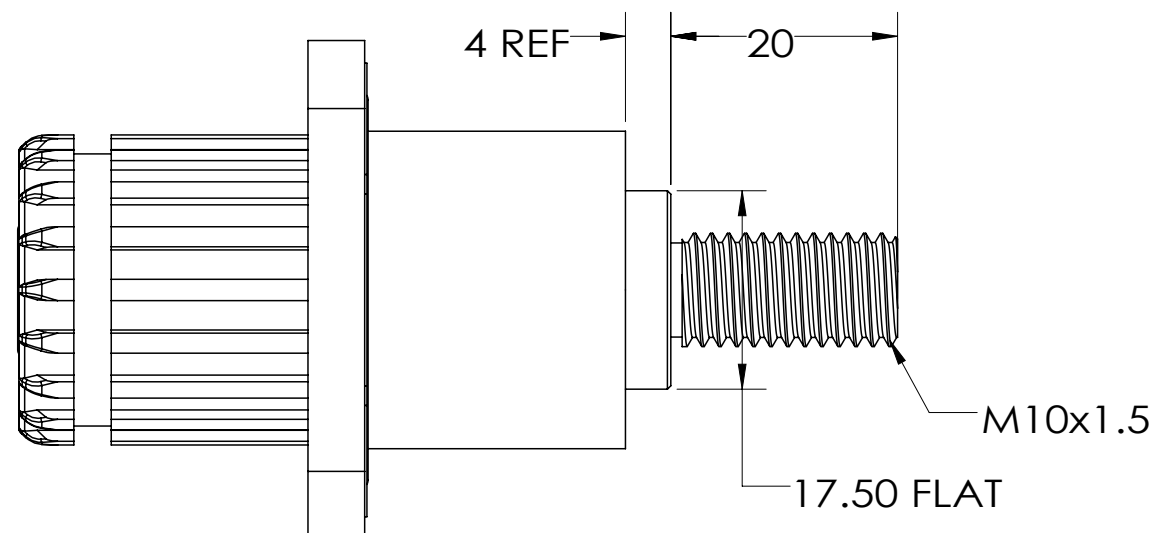
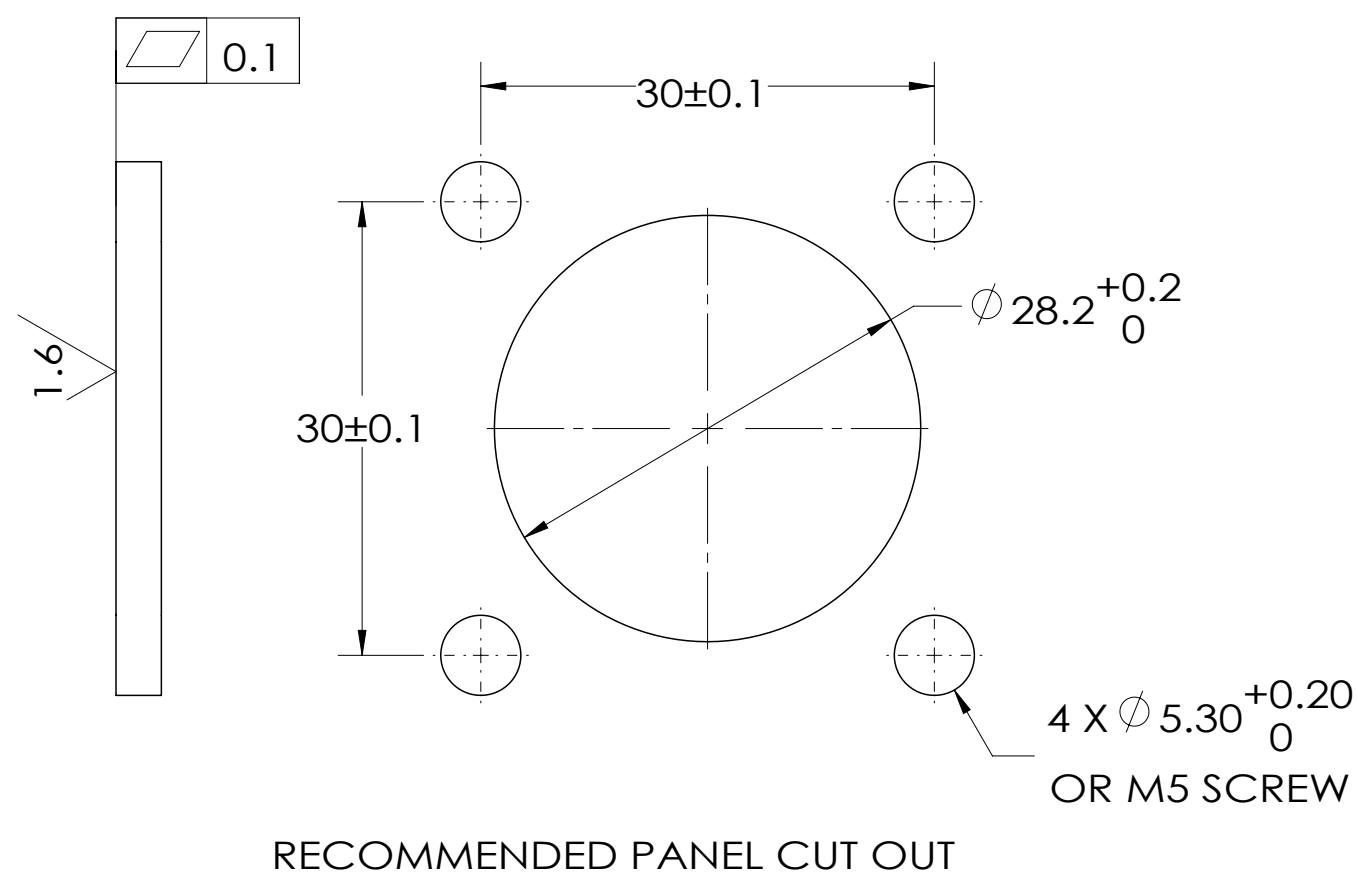

ITEM	OPTION	PART NUMBER	CODE NUMBER
COLOR	ORANGE	0	O
	BLACK	1	B
	RED	2	R
PIN TYPE	BUSBAR	1	B
	SCREW	2	T
SEALING	IP67(MATED)	0	S
	UNSEALING	1	N
KEYWAY (Y°)	20°	1	1
	30°	2	2

TABLE 1	
KEYWAY(Y°)	KEYWAY CODE
20°	K1
30°	K2

SPECIFICATIONS	
CURRENT RATING	360A MAX
VOLTAGE RATING	1500V DC
TEMPERATURE LIMIT	-40°C~125°C
AMBIENT TEMPERATURE	-40°C~80°C
CONDUCTION RESISTANCE OF CONNECTOR	0.5mΩ MAX
PROTECTION CLASS	IP67(MATED)
MATING CYCLE	100 CYCLES

3. DUST CAP SHOULD BE REMOVED BEFORE PLUG MATING IN.
2. IF CHOOSE UNSEALING TYPE, THERE WILL BE NO SEALING PART. (D)
1. THE REFERENCED PRODUCT SHALL BE COMPLIANT TO RoHS DIRECTIVE.

NOTES

THIS DOCUMENT CONTAINS PROPRIETARY INFORMATION AND SUCH INFORMATION MAY NOT BE DISCLOSED TO OTHERS FOR ANY PURPOSE OR USED FOR MANUFACTURING PURPOSES WITHOUT WRITTEN PERMISSION FROM THE AMPHENOL CORP.

Next Assembly

UNLESS OTHERWISE SPECIFIED		APPROVALS		DATE
LINEAR DIMENSIONS ARE IN MILLIMETERS		PREPARED BY:	Rock Yang	2021/8/28
TOLERANCES:		LEAD/PRODUCT ENGINEER:	Seven Xie	
DIM. RANGE		ENGINEERING MANAGER:	Rob Weng	
TOLERANCE		PRODUCT GROUP:	C&I	
THIRD ANGLE PROJECTION		AIPG DIVISION:	AIO	
		MATERIAL SPEC	PROCESS SPEC	
		N/A	N/A	

AMPHENOL CORPORATION
Amphenol Technology (Zhuhai) Co. Ltd.
No. 63 Xinghan Road, Sanzao Town, Jinwan, Zhuhai, PRC

12.0MM SURLOK PLUS RECEPTACLE
1500V TYPE

SIZE	CAGE CODE	DOCUMENT NUMBER	REV
C	77820	10-779598	D
SCALE: 2:1		REF: 10-765128	SHEET 1 OF 1