

## MFC140 series

### Ø7 mm flexible Rogowski coil

- Suitable for measuring currents up to several kA
  - High linearity
  - Very useful with large size or awkward shaped conductors or in places with limited access
  - Not damaged by overloads
  - Non-intrusive, no power drawn from the main
  - Thanks to its light weight, it can be changed on the measured conductor
  - Outdoor use on request
  - Totally shielded
  - Integrated *Fixing Kit* for quick and secure installation
- Delivered already calibrated
  - Very thin coil diameter: down to 7 mm
  - Provided with an accessory to secure the coil to the busbar
  - Measurement uniformity at any position of the conductor inside the coil



- Excellent degree of rejection to the external current conductor
- Possibility to seal the locking of the coil

### » General description

MFC140 is a flexible current transducer based on Rogowski principle, particularly suitable for measurement in combination with devices. MFC140 coils are available in different sizes and can be supplied according to customer's design, therefore they can be used in all those applications, in which traditional transducers are not fitting due to its size and/or weight.

Due to its specific features, flexible Rogowski coil is an extremely comfortable solution for current measurement and can be used in a number of cases where traditional current transducer is not the adequate solution.

MFC140 coil is provided with a shield against the influence of external magnetic fields, therefore it grants a stable measurement from low currents to several kA.

MFC140 can be also provided with built-in integrator, without needing of external devices for 90° phase shift compensation and frequency equalization. This is an advantage because there is no external box with consequent ease of use. MFC140 with built-in integrator can be connected to devices with differential input only.

The particular features of the Rogowski coils combined with the extremely flexible input programming of our meters, allow to carry out measurement by all applications.

MFC140-UI series features an integrated fixing mechanism for simple and secure, direct-to-conductor mounting (pag.3).

#### » Benefits

- Due to its structure, flexible Rogowski coils allows to embrace conductors or grouped cables, which are large and difficult to reach, without any hazard.
- The coil output gives a low voltage signal, therefore there is no danger from open-circuited secondary. This makes Rogowski transducers extremely suitable for temporary measurements, for example in combination with analysers.
- Unlike traditional current transformer with magnetic core, the Rogowski coil is a non-intrusive transducer. Since it has no hard core, it draws no power from the main circuit carrying the current to be measured.
- The absence of magnetic core grants a wide frequency response. This make MFC140 particularly suitable for measurement of harmonic content and transients.

#### » Applications

- Measuring devices, lab instrumentation
- Power monitoring & control systems
- DC ripple measurement
- Harmonics and transients monitoring
- Very high current monitoring

#### » Related Products

- RPS51

## » Available models

MODEL	Built-in INTEGRATOR
MFC140	
MFC140/F	•

## » What is a Rogowski coil?

Rogowski coils have been used for the detection and measurement of electric currents for decades. They are based on a simple principle: an “air-cored” coil is placed around the conductor in a toroidal fashion and the magnetic field produced by the current induces a voltage in the coil. The voltage output is proportional to the rate of change of current. This voltage is integrated, thus producing an output proportional to the current.

By using precision winding techniques, especially developed for the purpose, the coils are manufactured so that their output is not influenced by the position of the conductor within the toroid, and to reject interference from external magnetic fields caused, for example, from nearby conductors. Basically, a Rogowski coil current measuring system consists of a combination of a coil and conditioning electronics. Rogowski coil current transducers are used for the AC measurement.

They can be used in similar circumstances to current transformers but for many applications they have considerable advantages:

- Wide dynamic range, the same coil can be used to measure currents up to several kA.
- High linearity. According to the manufacturing (size, inductance value, ...) the maximum measurable frequency can range up to several kHz.
- Unlike traditional current transducers, there is no danger from open-circuited secondaries.
- They cannot be damaged by large overloads, are non-intrusive, draw no power from the main circuit carrying the current to be measured.

The transducer does not measure direct currents but, unlike a current transformer, it can carry out accurate measurements of AC component even if there is a large superimposed DC component. This feature is particularly useful for measuring ripple currents for example in battery charging systems.

## » Specifications

COIL	
Coil length:	15 ... 50 cm
Sensor internal diameter:	4 ... 15 cm
Cord diameter:	7.2 ±0.2 mm
Jacket material:	Polyphenylene and thermoplastic elastomer
Fastening:	Bayonet holder
Weight:	150 ... 500 g
ELECTRICAL CHARACTERISTICS	
Nominal output rate:	100 mV / kA @ 50 Hz (RMS values)
Max measurable current:	600 A with 15 ... 28 cm coil length
	2500 A with 29 ... 41 cm coil length
	5000 A with 42 ... 50 cm coil length
Coil resistance:	170 ... 690 Ω
Accuracy:	Class 0.5-A1 according to IEC 61869-10
Frequency:	50/60 Hz
Overvoltage category:	1000 V CAT III, 600 V CAT IV
Pollution degree:	3
Insulation test voltage:	7400 V <sub>RMS</sub> / 5 s
CONNECTION CABLE	
Type:	3 x 24 AWG shielded
Length:	3 m. Other lengths on request: 5, 7, 10, 15 m Outdoor use: <b>min. 5 m cable</b> required
ENVIRONMENTAL CONDITIONS	
Protection degree:	IP68
Altitude:	Up to 2000 m over sea-level
Operating temperature:	-40 ... +75°C up to 2500 A with 15 ... 41 cm coil length
	-40 ... +60°C up to 5000 A with 42 ... 50 cm coil length
Storage temperature:	-40 ... +90°C
Relative humidity:	0 ... 95%
Installation and use:	Indoor. Outdoor on request
STANDARD COMPLIANCE	
IEC standards:	IEC 61010-1, IEC 61010-2-032, IEC 60529

## » Mounting & Fixing

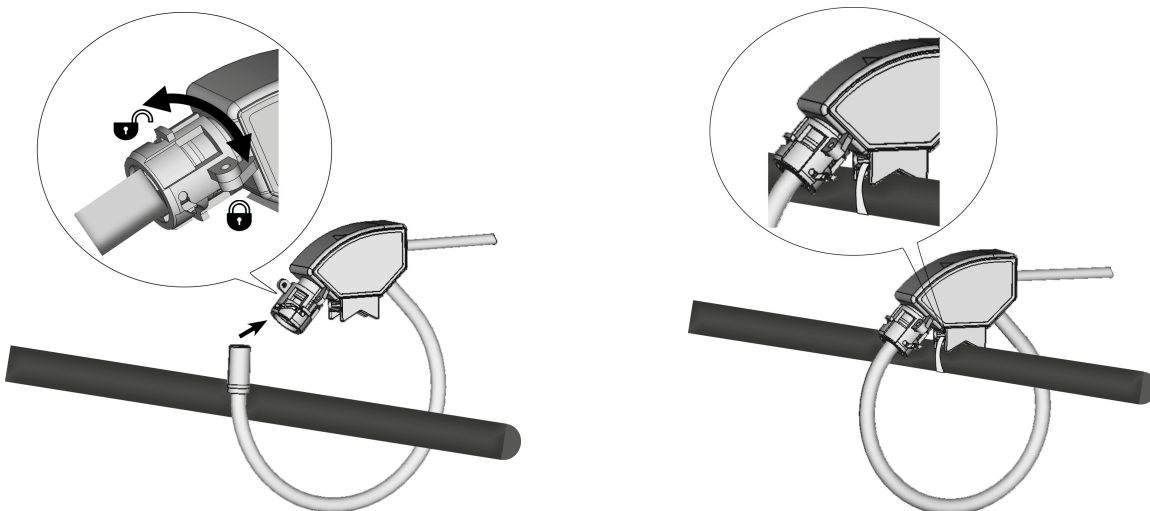

ORDER CODE	COIL DETAIL		CABLE DETAIL	COLOUR	CALIBRATED
	Length	Internal diameter [cm]	3 m	Yellow	Yes
<b>MFC140 (100mV/1kA@50Hz OUTPUT VALUE)</b>					
3801.0001.0001	15	~4 (4x5)	•	•	•
3801.0002.0001	28	~8	•	•	•
3801.0003.0001	40	~12	•	•	•
3801.0004.0001	50	~15	•	•	•

	ALL MODELS	ONLY MODEL WITHOUT INTEGRATOR
<b>OPTIONS AVAILABLE ONLY ON REQUEST (SUBJECT TO MOQ)</b>		
Cable length different from standard (3m): 5, 7, 10, 15 m	•	
Calibrated for customer device (input impedance value of device to be specified)		•
Different coil colour	•	
Outdoor use (min. 5 m cable required)	•	

To be indicated together with the selected order code from the list above.

NOTE: Subject to change without notice

**algodue**<sup>®</sup>  
ELETTRONICA

Innovative Electronic Systems

Via P. Gobetti, 16/F - 28014 Maggiora (NO) - Italy - Tel.: +39 0322 89307

sales@algodue.it - [www.algodue.com](http://www.algodue.com)

82PG01\_2\_202601\_2