

THIS DRAWING IS SUPPLIED FOR INFORMATION ONLY. DESIGN FEATURES, SPECIFICATIONS, AND PERFORMANCE DATA SHOWN HEREON ARE THE PROPERTY OF THE AMPHENOL CORPORATION. NO RIGHTS OF REPRODUCTION ARE IMPLIED. ALL DIMENSIONS ARE SUBJECT TO NORMAL MANUFACTURING VARIATIONS.

Customer Drawing

REVISIONS					
REV	ZONE	ECO	DESCRIPTION	DATE	BY APPR
A	--	--	Updated	07/04/14	RW EC
C	--	--	Rear nut increase 1mm, reduced inner diameter	09/08/15	RW EC
D	--	--	Add dust cap	01/15/16	RW GX
E	--	--	Change tail cover	10/17/16	SW RW
F	--	--	Add wire harness fixing point description	06/27/17	Sam Julie
G	--	--	Increase rocker opening and closing size	08/30/18	Fred JL
H	--	--	change shell, change Cable seal for 35mm2 connector	11/17/20	Steven JL

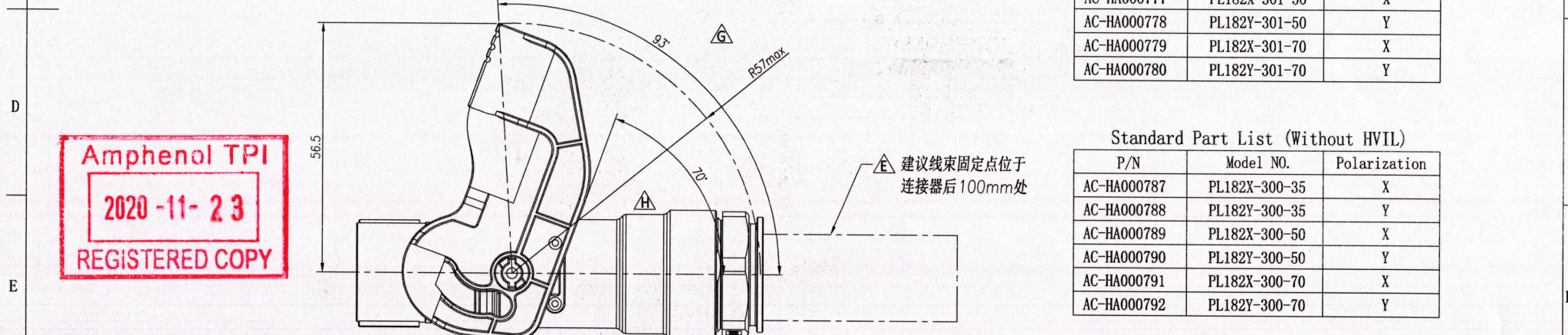
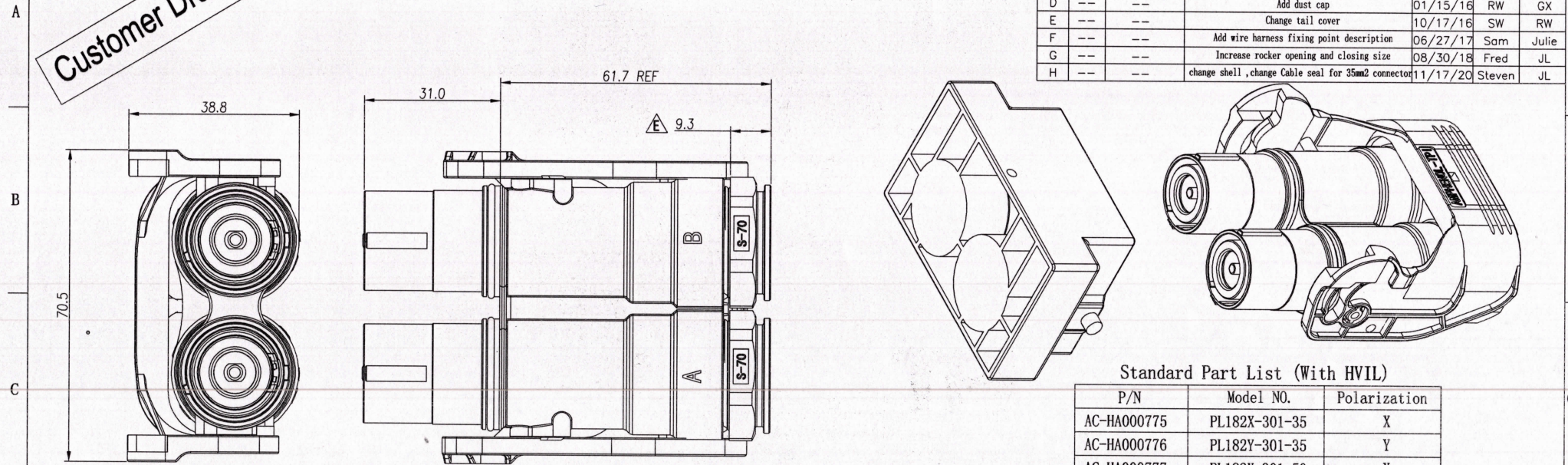

Standard Part List (With HVIL)

P/N	Model NO.	Polarization
AC-HA000775	PL182X-301-35	X
AC-HA000776	PL182Y-301-35	Y
AC-HA000777	PL182X-301-50	X
AC-HA000778	PL182Y-301-50	Y
AC-HA000779	PL182X-301-70	X
AC-HA000780	PL182Y-301-70	Y

Standard Part List (Without HVIL)

P/N	Model NO.	Polarization
AC-HA000787	PL182X-300-35	X
AC-HA000788	PL182Y-300-35	Y
AC-HA000789	PL182X-300-50	X
AC-HA000790	PL182Y-300-50	Y
AC-HA000791	PL182X-300-70	X
AC-HA000792	PL182Y-300-70	Y

- 规格参数 (Spec.):
- 工作温度 Operating temperature: $-40^{\circ}\text{C} \sim +125^{\circ}\text{C}$.
 - 额定电流 Current rating (Connector Only): \triangle
35mm²:150A; 50mm²:200A; 70mm²:250A;
 - 额定电压 Operating voltage:1000 VDC.
 - 耐电压 Dielectric withstanding voltage: 5000 VDC.
 - 防护等级 Protection class:IP67 & IP2X.
 - 电磁屏蔽 Shielding.
 - 机械寿命 Mating cycle:100 Min. \triangle
 - 带自动二次锁扣 Automatic secondary lock.
 - 带高压互锁 Electrical interlock (HVIL).
 - 对配插座见图纸 Mating receptacle see drawing: PL082-300.

订购信息 Ordering Information

PL18 2 X - 30 1 - 70

键位及颜色 Key "X" Key "Y" Key	高压互锁 HVIL 0, 不带互锁 No HVIL 1, 带互锁 With HVIL	线缆大小 Cable Size "70"=70mm ² "50"=50mm ² "35"=35mm ²
---------------------------------	--	---

AMPHENOL TPI

Amphenol Technical Products International Asia.

第三角投影 THIRD ANGLE PROJECTION	页码 SHEET	幅面 SIZE	版次 REV.	比例 SCALE	PART NAME: PwrLok 10mm 2POS Plug Conn
	1 OF 1	A3	H		DWG NO: PL182()-300
签名 SIGNATURE Steven	日期 DATE 11/17/20	UNLESS OTHERWISE SPECIFIED		CUST PART #: N/A	
制图 DRAWN	审核 CHECKED	批准 APPROVAL	1) All dimensions are in metric (mm). 2) Tolerances are as follows: 0 PL DEC ± 1.00 1 PL DEC ± 0.50 2 PL DEC ± 0.20		CUST REV. -
			Angles $\pm 1^{\circ}$		

THIS DRAWING IS SUPPLIED FOR INFORMATION ONLY. DESIGN FEATURES, SPECIFICATIONS AND PERFORMANCE DATA SHOWN HEREON ARE THE PROPERTY OF THE AMPHENOL CORPORATION. NO RIGHTS OF REPRODUCTION ARE IMPLIED. ALL DIMENSIONS ARE SUBJECT TO NORMAL MANUFACTURING VARIATIONS.

Customer Drawing

A
B
C
D
E
F

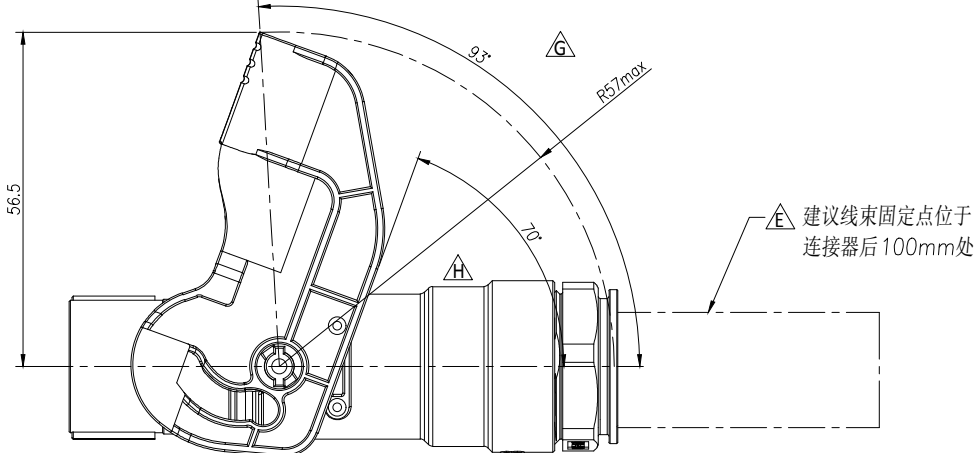
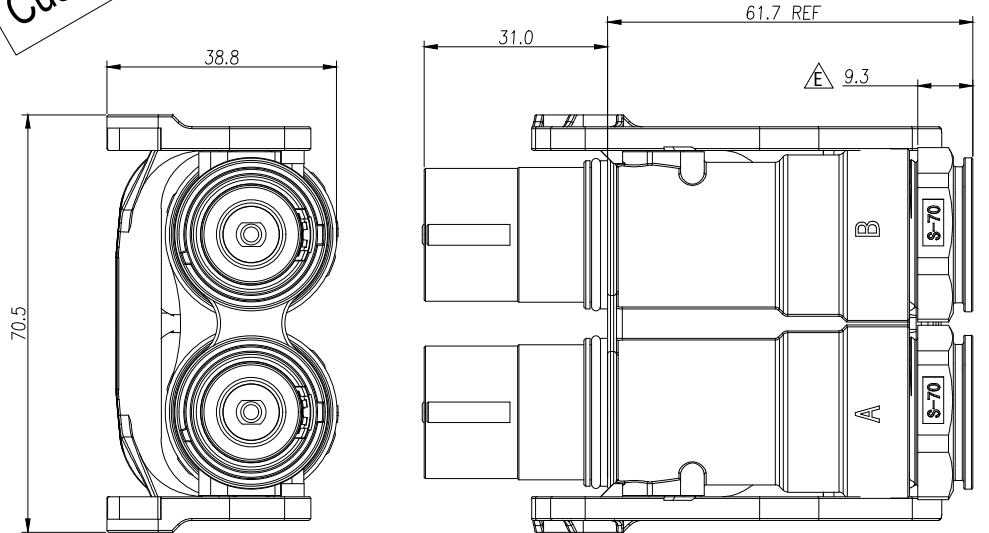

- 规格参数 (Spec.):
1. 工作温度 Operating temperature: -40° C ~ +125° C.
 2. 额定电流 Current rating (Connector Only): \triangleleft
35mm²:150A; 50mm²:200A; 70mm²:250A;
 3. 额定电压 Operating voltage:1000 VDC.
 4. 耐电压 Dielectric withstanding voltage: 5000 VDC.
 5. 防护等级 Protection class:IP67 & IP2X.
 6. 电磁屏蔽 Shielding.
 7. 机械寿命 Mating cycle:100 Min. \triangleleft
 8. 带自动二次锁扣 Automatic secondary lock.
 9. 带高压互锁 Electrical interlock (HVIL).
 10. 对插座座见图纸 Mating receptacle see drawing: PL082-300.

订购信息 Ordering Information

PL18 2 X - 30 1 - 70

键位及颜色 Key "X" Key "Y" Key	高压互锁 HVIL 0, 不带互锁 No HVIL 1, 带互锁 With HVIL	线缆大小 Cable Size "70"=70mm ² "50"=50mm ² "35"=35mm ²
---------------------------------	--	---

REV		ZONE	ECO	DESCRIPTION	DATE	BY	APPR
A	--	--	--	Updated	07/04/14	RW	EC
C	--	--	--	Rear nut increase 1mm, reduced inner diameter	09/08/15	RW	EC
D	--	--	--	Add dust cap	01/15/16	RW	GX
E	--	--	--	Change tail cover	10/17/16	SW	RW
F	--	--	--	Add wire harness fixing point description	06/27/17	Sam	Julie
G	--	--	--	Increase rocker opening and closing size	08/30/18	Fred	JL
H	--	--	--	change shell , change Cable seal for 35mm2 connector	11/17/20	Steven	JL

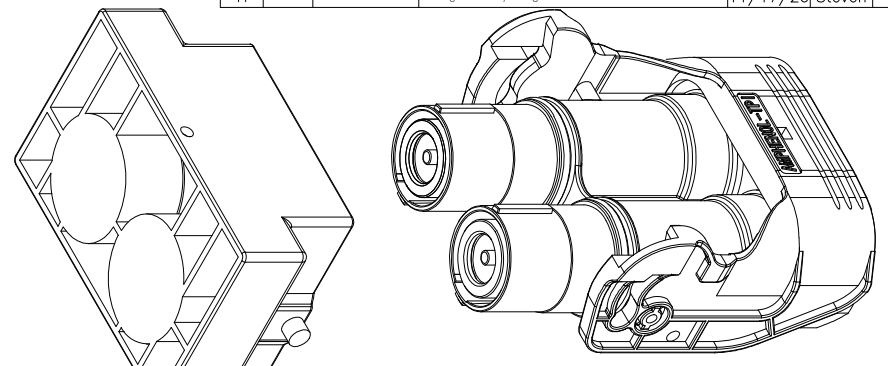

Standard Part List (With HVIL)

P/N	Model NO.	Polarization
AC-HA000775	PL182X-301-35	X
AC-HA000776	PL182Y-301-35	Y
AC-HA000777	PL182X-301-50	X
AC-HA000778	PL182Y-301-50	Y
AC-HA000779	PL182X-301-70	X
AC-HA000780	PL182Y-301-70	Y

Standard Part List (Without HVIL)

P/N	Model NO.	Polarization
AC-HA000787	PL182X-300-35	X
AC-HA000788	PL182Y-300-35	Y
AC-HA000789	PL182X-300-50	X
AC-HA000790	PL182Y-300-50	Y
AC-HA000791	PL182X-300-70	X
AC-HA000792	PL182Y-300-70	Y

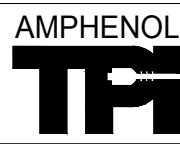

Amphenol Technical Products International Asia.

第三角投影 THIRD ANGLE PROJECTION	页面 SHEET	幅面 SIZE	版次 REV.	比例 SCALE	PART NAME: PwrLok 10mm 2POS Plug Conn
\triangleleft	1 OF 1	A3	H		DWG NO: PL182()-300
签名 SIGNATURE 制图 DRAWN 审核 CHECKED 批准 APPROVAL	日期 DATE Steven 11/17/20	UNLESS OTHERWISE SPECIFIED 1) All dimensions are in metric(mm). 2) Tolerances are as follows: 0 PL DEC ±1.00 1 PL DEC ±0.50 2 PL DEC ±0.20			CUST PART #: N/A
		Angles ±1°			CUST REV. -

1 2 3 4 5 6 7 8